



MORGAN & CLAYPOOL PUBLISHERS

# Circuit Analysis with Multisim

David Báez-López  
Félix E. Guerrero-Castro

*SYNTHESIS LECTURES ON  
DIGITAL CIRCUITS AND SYSTEMS*

Mitchell Thornton, *Series Editor*



# **Circuit Analysis with Multisim**

# Synthesis Lectures on Digital Circuits and Systems

## Editor

**Mitchell A. Thornton**, *Southern Methodist University*

The Synthesis Lectures on Digital Circuits and Systems series is comprised of 50- to 100-page books targeted for audience members with a wide-ranging background. The Lectures include topics that are of interest to students, professionals, and researchers in the area of design and analysis of digital circuits and systems. Each Lecture is self-contained and focuses on the background information required to understand the subject matter and practical case studies that illustrate applications. The format of a Lecture is structured such that each will be devoted to a specific topic in digital circuits and systems rather than a larger overview of several topics such as that found in a comprehensive handbook. The Lectures cover both well-established areas as well as newly developed or emerging material in digital circuits and systems design and analysis.

## Circuit Analysis with Multisim

David Báez-López and Félix E. Guerrero-Castro

2011

## Microcontroller Programming and Interfacing Texas Instruments MSP430, Part I

Steven F. Barrett and Daniel J. Pack

2011

## Microcontroller Programming and Interfacing Texas Instruments MSP430, Part II

Steven F. Barrett and Daniel J. Pack

2011

## Pragmatic Electrical Engineering: Systems and Instruments

William Eccles

2011

## Pragmatic Electrical Engineering: Fundamentals

William Eccles

2011



[Introduction to Embedded Systems: Using ANSI C and the Arduino Development Environment](#)

David J. Russell  
2010

[Arduino Microcontroller: Processing for Everyone! Part II](#)

Steven F. Barrett  
2010

[Arduino Microcontroller Processing for Everyone! Part I](#)

Steven F. Barrett  
2010

[Digital System Verification: A Combined Formal Methods and Simulation Framework](#)

Lun Li and Mitchell A. Thornton  
2010

[Progress in Applications of Boolean Functions](#)

Tsutomu Sasao and Jon T. Butler  
2009

[Embedded Systems Design with the Atmel AVR Microcontroller: Part II](#)

Steven F. Barrett  
2009

[Embedded Systems Design with the Atmel AVR Microcontroller: Part I](#)

Steven F. Barrett  
2009

[Embedded Systems Interfacing for Engineers using the Freescale HCS08 Microcontroller II: Digital and Analog Hardware Interfacing](#)

Douglas H. Summerville  
2009

[Designing Asynchronous Circuits using NULL Convention Logic \(NCL\)](#)

Scott C. Smith and Jia Di  
2009

[Embedded Systems Interfacing for Engineers using the Freescale HCS08 Microcontroller I: Assembly Language Programming](#)

Douglas H. Summerville  
2009

[Developing Embedded Software using DaVinci & OMAP Technology](#)

B.I. (Raj) Pawate

2009

[Mismatch and Noise in Modern IC Processes](#)

Andrew Marshall

2009

[Asynchronous Sequential Machine Design and Analysis: A Comprehensive Development of the Design and Analysis of Clock-Independent State Machines and Systems](#)

Richard F. Tinder

2009

[An Introduction to Logic Circuit Testing](#)

Parag K. Lala

2008

[Pragmatic Power](#)

William J. Eccles

2008

[Multiple Valued Logic: Concepts and Representations](#)

D. Michael Miller and Mitchell A. Thornton

2007

[Finite State Machine Datapath Design, Optimization, and Implementation](#)

Justin Davis and Robert Reese

2007

[Atmel AVR Microcontroller Primer: Programming and Interfacing](#)

Steven F. Barrett and Daniel J. Pack

2007

[Pragmatic Logic](#)

William J. Eccles

2007

[PSpice for Filters and Transmission Lines](#)

Paul Tobin

2007

[PSpice for Digital Signal Processing](#)

Paul Tobin

2007

PSpice for Analog Communications Engineering

Paul Tobin

2007

PSpice for Digital Communications Engineering

Paul Tobin

2007

PSpice for Circuit Theory and Electronic Devices

Paul Tobin

2007

Pragmatic Circuits: DC and Time Domain

William J. Eccles

2006

Pragmatic Circuits: Frequency Domain

William J. Eccles

2006

Pragmatic Circuits: Signals and Filters

William J. Eccles

2006

High-Speed Digital System Design

Justin Davis

2006

Introduction to Logic Synthesis using Verilog HDL

Robert B. Reese and Mitchell A. Thornton

2006

Microcontrollers Fundamentals for Engineers and Scientists

Steven F. Barrett and Daniel J. Pack

2006

Copyright © 2011 by Morgan & Claypool

All rights reserved. No part of this publication may be reproduced, stored in a retrieval system, or transmitted in any form or by any means—electronic, mechanical, photocopy, recording, or any other except for brief quotations in printed reviews, without the prior permission of the publisher.

Circuit Analysis with Multisim

David Báez-López and Félix E. Guerrero-Castro

[www.morganclaypool.com](http://www.morganclaypool.com)

ISBN: 9781608457564      paperback

ISBN: 9781608457571      ebook

DOI 10.2200/S00386ED1V01Y201109DCS035

A Publication in the Morgan & Claypool Publishers series

*SYNTHESIS LECTURES ON DIGITAL CIRCUITS AND SYSTEMS*

Lecture #35

Series Editor: Mitchell A. Thornton, *Southern Methodist University*

Series ISSN

Synthesis Lectures on Digital Circuits and Systems

Print 1932-3166    Electronic 1932-3174

# Circuit Analysis with Multisim

David Báez-López and Félix E. Guerrero-Castro  
Universidad de las Américas-Puebla, México

*SYNTHESIS LECTURES ON DIGITAL CIRCUITS AND SYSTEMS #35*



MORGAN & CLAYPOOL PUBLISHERS

## ABSTRACT

This book is concerned with circuit simulation using National Instruments Multisim. It focuses on the use and comprehension of the working techniques for electrical and electronic circuit simulation. The first chapters are devoted to basic circuit analysis. It starts by describing in detail how to perform a DC analysis using only resistors and independent and controlled sources. Then, it introduces capacitors and inductors to make a transient analysis. In the case of transient analysis, it is possible to have an initial condition either in the capacitor voltage or in the inductor current, or both. Fourier analysis is discussed in the context of transient analysis. Next, we make a treatment of AC analysis to simulate the frequency response of a circuit. Then, we introduce diodes, transistors, and circuits composed by them and perform DC, transient, and AC analyses. The book ends with simulation of digital circuits.

A practical approach is followed through the chapters, using step-by-step examples to introduce new Multisim circuit elements, tools, analyses, and virtual instruments for measurement. The examples are clearly commented and illustrated. The different tools available on Multisim are used when appropriate so readers learn which analyses are available to them. This is part of the learning outcomes that should result after each set of end-of-chapter exercises is worked out.

## KEYWORDS

circuit simulation, electrical circuits, electronic circuits, DC analysis, transient analysis, AC analysis, frequency response, Bode plots, Fourier analysis, operational amplifiers, digital circuit simulation, virtual instruments

*This book is dedicated to Ofelia, who is the best part of each day.*

*J.M. David Báez-López*





# Contents

	<b>Acknowledgments</b> .....	<b>xv</b>
<b>1</b>	<b>Introduction to Circuit Simulation</b> .....	<b>1</b>
1.1	What is Circuit Simulation .....	1
1.2	What is Multisim .....	1
1.3	Organization of the Book .....	2
	Selected Bibliography .....	2
<b>2</b>	<b>Resistive Circuits</b> .....	<b>3</b>
2.1	Circuit Editing .....	3
2.1.1	Basic DC Analysis .....	6
2.2	Multisim Measurement Instruments .....	12
2.2.1	Basic Measurement Instruments .....	12
2.2.2	The Multimeter .....	17
2.2.3	The Oscilloscope .....	19
2.2.4	The Wattmeter .....	21
2.2.5	The Probe .....	21
2.3	Breadboard Circuit Capture .....	22
2.3.1	Three Dimensional Virtual Components .....	26
2.4	Use of the Multisim Grapher .....	26
2.5	Circuits with Controlled Sources .....	29
2.5.1	Circuits with VCVS .....	29
2.5.2	Circuits with ICIS .....	30
2.5.3	Circuits with VCIS (G-source) .....	35
2.5.4	Circuits with ICVS (H-source) .....	35
2.6	Conclusions .....	35
<b>3</b>	<b>Time Domain Analysis – Transient Analysis</b> .....	<b>43</b>
3.1	Capacitors and Inductors .....	43
3.2	Input Signal Types .....	44
3.2.1	EXPONENTIAL Signal .....	44

3.2.2	PULSE Signal	45
3.2.3	PIECEWISE_LINEAR signal (PWL)	46
3.2.4	Sine Wave AC Signal	46
3.2.5	Frequency Modulated Signal FM	47
3.2.6	Thermal Noise Signal	47
3.2.7	Amplitude Modulated Signal AM	49
3.3	Time Domain Analysis – Transient Analysis	49
3.3.1	Use of Cursors	51
3.4	The Oscilloscope and the Distortion Analyzer	54
3.4.1	The Oscilloscope	57
3.4.2	The Distortion Analyzer	60
3.5	Fourier Analysis	63
3.6	Additional Examples	66
3.7	Conclusions	81
<b>4</b>	<b>Frequency Domain Analysis – AC Analysis</b>	<b>87</b>
4.1	AC Analysis – Frequency Response	87
4.1.1	Loops with no Resistance	91
4.2	Bode Plots	94
4.3	Pole-Zero Analysis	97
4.4	Examples	104
4.5	Conclusions	111
<b>5</b>	<b>Semiconductor Devices</b>	<b>117</b>
5.1	Diodes	117
5.2	Transistors	120
5.3	Bipolar Transistors	120
5.4	Junction Field Effect Transistors-JFET's	128
5.5	Metal Oxide Semiconductor Field Effect Transistors-MOSFET's	137
5.6	Additional Examples	142
5.7	Conclusions	147
	Selected Bibliography	158
<b>6</b>	<b>Digital Circuits</b>	<b>159</b>
6.1	Digital Circuit Components	159
6.2	Tools for Digital Circuit Analysis	163

6.2.1	Logic Analyzer .....	163
6.2.2	Word Generator .....	163
6.2.3	Logic Converter .....	164
6.3	Examples .....	168
6.4	Conclusions .....	171
	<b>Authors' Biographies .....</b>	<b>181</b>



# Acknowledgments

The great feedback received from my students and colleagues throughout the years I worked in the UDLAP Electronics lab is acknowledged. My sincere gratitude to Lalo Jiménez, Mariano Fernández, and Lalo López. Also, to my partners at Hackerspace Cholula — Chö, Mondí, Jim, Maw. They are the daily ongoing inspiration for all my projects.

Félix E. Guerrero-Castro  
October 2011



## CHAPTER 1

# Introduction to Circuit Simulation

## 1.1 WHAT IS CIRCUIT SIMULATION

Electronics have an important place in daily life. So important, in fact, that the modern world cannot be conceived of without electronics. From reading and writing e-mails, using our cell phone to call and sent text messages, writing a letter in a word processor, managing data in a spreadsheet, controlling traffic in a busy downtown, tracking objects in a manufacturing plant, watching the ball game on a TV set, buying and selling stocks, etc., electronic circuits are used to perform these tasks. Nowadays, modern electronic circuits are composed by millions of transistors. For example, an Intel microprocessor needs more than 500 million transistors to be able to handle data at a speed greater than 2.5 GHz and an iPhone with an A6 processor can have almost the same number of transistors. To test these devices before the actual manufacturing needs extensive simulation of the circuit to ensure proper performance once the chip is in the computer or phone. Failure to carry on a proper simulation procedure can cost a company losses in the millions of dollars.

## 1.2 WHAT IS MULTISIM

There are several circuit simulators on the market. The most popular simulator is SPICE (Simulation Program with Integrated Circuit Emphasis) designed at the University of California at Berkeley. This simulator is so powerful that commercial simulators are based on it. Of the many simulators available, Multisim has emerged as the best for circuit simulation. Multisim is a SPICE-based simulator, produced by National Instruments Inc. in Austin, TX, with a schematic-capture interface that allows easy circuit topology input and specification of simulation data. An evaluation version can be downloaded from <http://ni.com>.

Circuit analysis using Multisim allows the user to:

- observe the circuit behavior before the actual manufacturing;
- use ideal components to isolate design and circuit limitations;
- make measurements that are hard to make in the real circuit because:
  - o they might damage the circuit,
  - o they are affected by electric noise;

## 2 SELECTED BIBLIOGRAPHY

- not possible because of a lack of proper measurement equipment;
- perform repeated simulations with parametric values for a component;
- observe temperature dependence of the circuit behavior;
- observe circuit behavior under parasitic elements due to real components.

These are only a few of the many advantages of using circuit simulation.

## 1.3 ORGANIZATION OF THE BOOK

The book is organized as follows.

Chapter 2 is an introduction to the Multisim interface and covers the basic DC analysis. It introduces basic measurement instruments. For novice users, the chapter presents an option to wire up the circuit in a pictorial representation. Finally, it introduces the grapher, a Multisim tool that allows us to plot the different signals in the simulation. In this chapter, the elements used are resistors, independent voltage and current sources, and controlled sources.

Chapter 3 introduces capacitors and inductors and transient analysis. It describes in detail the different sources available for transient analysis. The chapter ends with Fourier analysis.

Chapter 4 is dedicated to frequency analysis. The results are plotted in Bode plots. It includes pole-zero analysis.

Chapter 5 covers semiconductor devices such as diodes and transistors. They are used in integrated circuits and thus, they are very important electronic circuits.

Chapter 6 covers simulation of digital circuits. The digital blocks are represented internally by subcircuits but for the user they are simple blocks. Mixed-mode circuits can be simulated by Multisim.

The book can be read in the order described. For users interested mainly in digital circuits, they can skip Chapters 4 and 5 and proceed to Chapter 6 after having read Chapter 3.

## SELECTED BIBLIOGRAPHY

For readers interested in further reading about simulation, the following books provide further insight into the SPICE simulator.

- [1] L.W. Nagel, SPICE2: A computer program to simulate semiconductor circuits, Memorandum No. M520, Department of Electrical Engineering, University of California at Berkeley, May 1975.
- [2] P. Antognetti and G. Massobrio, Semiconductor device modeling with SPICE, McGraw-Hill Book Co., New York, 1988.



## CHAPTER 2

# Resistive Circuits

The circuits composed with resistors and sources are the simplest circuits in electrical and electronics engineering. Although their applications are very limited, they will serve us to show the general input format for Multisim. In this chapter we cover the foundations to start using Multisim. The primary analysis in Multisim is the DC Operating Point analysis which is done previous to any other analysis type. Analysis results are displayed in the Grapher, the output interface in Multisim. Every result from the simulation is displayed in the Grapher, either numerical or graphical. Basic measurement instruments, such as oscilloscopes and multimeters, are described in the chapter. We end the chapter by introducing the use of the four types of controlled sources.

The first step is to follow installation instructions. Once we are finished with the installation, we start Multisim from the Start menu and proceed with the next section.

## 2.1 CIRCUIT EDITING

The first circuit we analyze in Multisim is shown in Fig. 2.1. It is a resistive circuit with an independent DC voltage source.

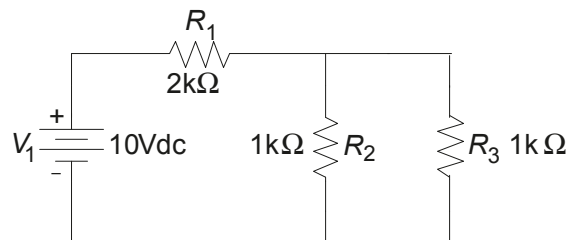

**Figure 2.1:** Resistive circuit with an independent DC voltage source.

This circuit has three resistors and an independent voltage source. When we open Multisim, it shows a blank schematic page where we can draw our schematic circuit, several windows, and some toolbars, as shown in Fig. 2.2. Some of the icons in the toolbars are conventional ones such as Open file, Copy, Save, etc. The windows shown are the larger window to draw the circuit called the Design Toolbox window, and the Results/Nets/Components window. One of the toolbars is the Components toolbar and it contains links to some of the different components available to draw our circuits. Table 2.1 gives a short description of the icons available in this toolbar.

## 4 2. RESISTIVE CIRCUITS

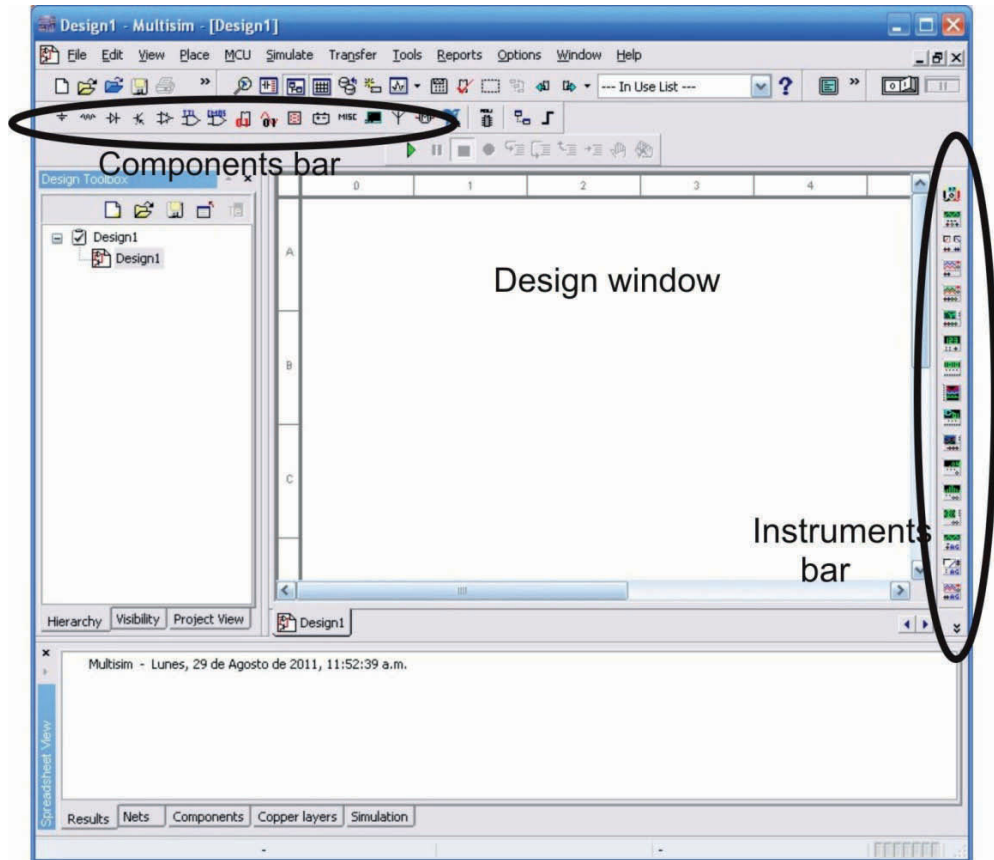











**Figure 2.2:** Multisim window.

Note that a schematic page with a default name Design1 is open. This opens the window shown in Fig. 2.3. There we can begin to draw our circuit. We first place the DC voltage source. We do this by selecting the Sources icon (the left-most icon) in the Components Toolbar. There we select DC\_POWER→POWER\_SOURCES→DC\_POWER and press OK. The DC voltage source is shown in the schematic page attached to the mouse. It can be moved along the schematic page by moving the mouse. It is placed in the desired position by left clicking the mouse. The same window is open again to select a new component. If we wish to place another DC voltage source we select it and press the OK button.

Now we place the resistors, otherwise we press the Close button. We click on the Basic icon in the Component toolbar. The window in Fig. 2.4 is open. There are two possibilities to choose a resistor. The first one is in the RATED VIRTUAL set of components and the second one is in

**Table 2.1:** Icons available in the Components toolbar.

	<b>Sources and grounds.</b>
	<b>Basic.</b> Resistors, capacitors, inductors, transformers, and other passive components
	<b>Diodes.</b> Different diode types.
	<b>Transistors.</b> Bipolar, JFETs, and MOSFETs.
	<b>Analog.</b> OpAmps, Comparators, other analog ICs.
	<b>TTL.</b> TTL logic parts.
	<b>Miscellaneous digital circuits.</b>
	<b>Mixed Mode ICs.</b>
	<b>Indicator.</b> Displays, voltmeters, lamps, etc.
	<b>Power components.</b>
	<b>Electromechanical.</b> Rotary switches, motors, etc.

the RESISTOR set. The VIRTUAL set has components that can have any value, for example, we can place a resistor with a value of 23.457 ohms. In the resistor set we can only place resistors with predetermined commercial values. In our example we can use both sets. For R1 we use the RATED VIRTUAL set and for R2 and R3 we use the resistor set. Thus, after placing R1 we are returned to the same window to select the following component and there we press the Close button. For R2 and R3 we select the RESISTOR set and place them in the schematic page (see Fig. 2.5 (a)). To place R2 in a vertical position we select it with the mouse and press Control-R. (See Fig. 2.5 (b)). We repeat with R3. Finally, we have to place a ground symbol, which it is available from the sources icon. We note there are two ground symbols: GROUND and DGND. The last one is used in digital circuit simulation. We choose GROUND and place it on the schematic page. The schematic page with the components is shown in Fig. 2.5.

To wire up the components we place the pointer in the upper end of the DC power source, we click the left mouse button to start the wire, then drag the pointer to the left end of R1 and left click again. A wire connecting the voltage source and resistor R1 has been created. Now, connect the remaining elements. The complete circuit is shown in Fig. 2.6. In this figure, node numbers are shown next to each node. Node numbers or names are displayed if we select in the main menu Edit → Properties which opens the dialog window shown in Fig. 2.7 and in the Net names box we select Show all, as shown there.

## 6 2. RESISTIVE CIRCUITS

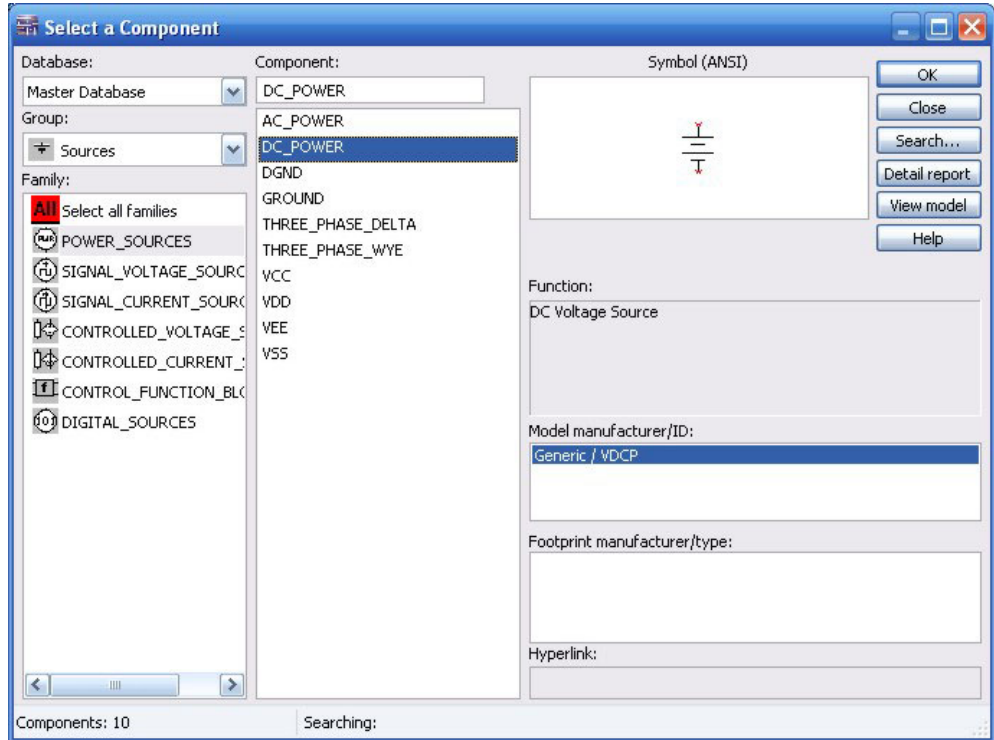

**Figure 2.3:** Selecting the DC\_POWER source.

The next step is to change the values of resistor R1. We click on the 1K values and the window of Fig. 2.8 is open. In the Value tab we change 1 to 2 (make sure that  $k\Omega$  is shown in the pull down menu next to the value field) and click OK. Resistor R1 is now  $2k\Omega$ . In the same way we change the value of the source V1 to 10 V. The final circuit is shown in Fig. 2.9. Finally, save the circuit as Example 2-1. The circuits saved have an extension ms11, indicating that the design was done on Multisim 11 (the latest version as of this writing).

### 2.1.1 BASIC DC ANALYSIS

We are now ready to simulate our circuit. The basic analysis performed by Multisim is the DC Operating Point Analysis. This type of analysis is performed even when a different type of analysis is chosen (such as AC or transient). This type of analysis calculates the node voltages and the currents through the voltage sources. We perform this analysis by selecting from the main menu Simulate  $\rightarrow$  Analyses  $\rightarrow$  DC Operating Point as shown in Fig. 2.10. This action takes us to the window shown in Fig. 2.11 where we choose the variables to display. We select I(v1) and V(2) as our variables, then

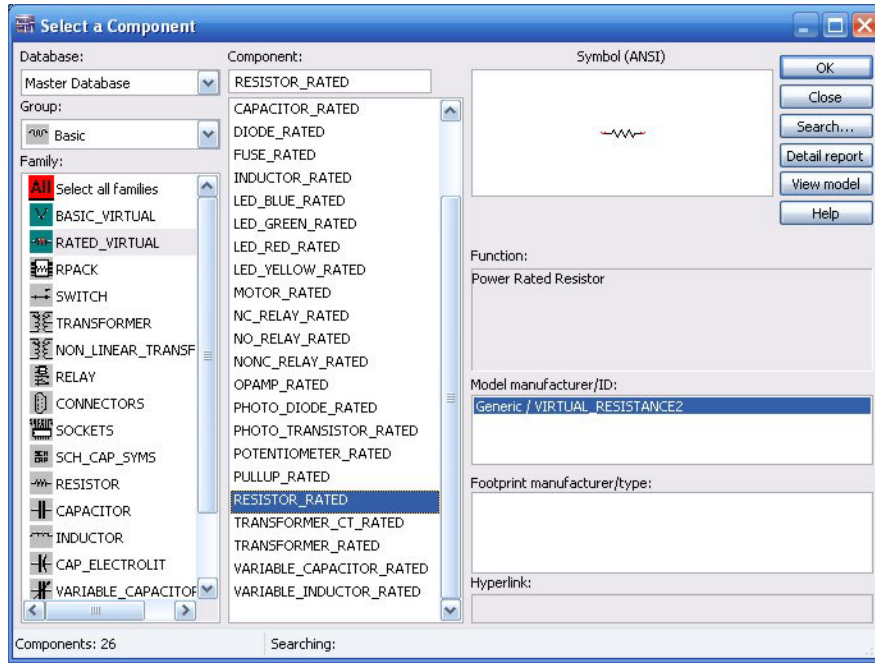

Figure 2.4: Selecting resistor R1.

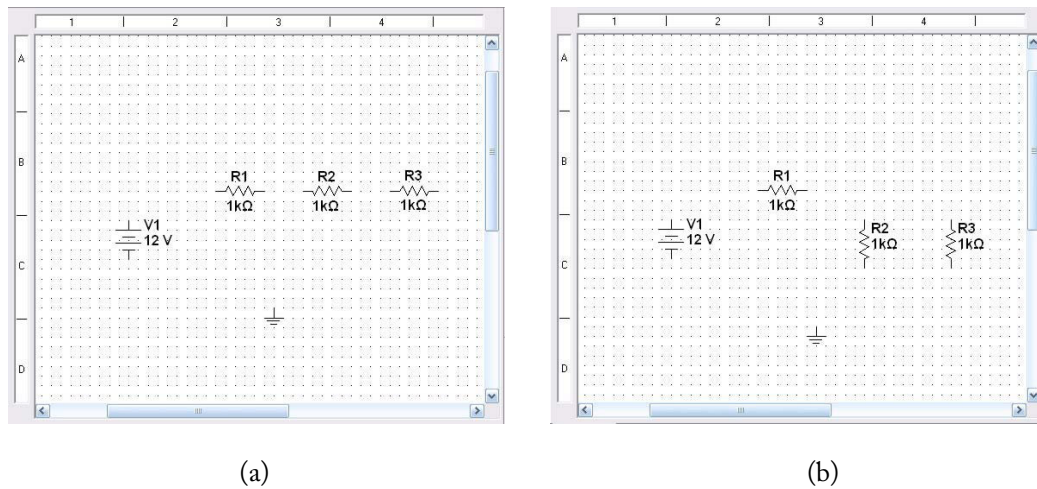

Figure 2.5: (a) Schematic page with components, (b) With resistors R2 and R3 after rotation.

## 8 2. RESISTIVE CIRCUITS

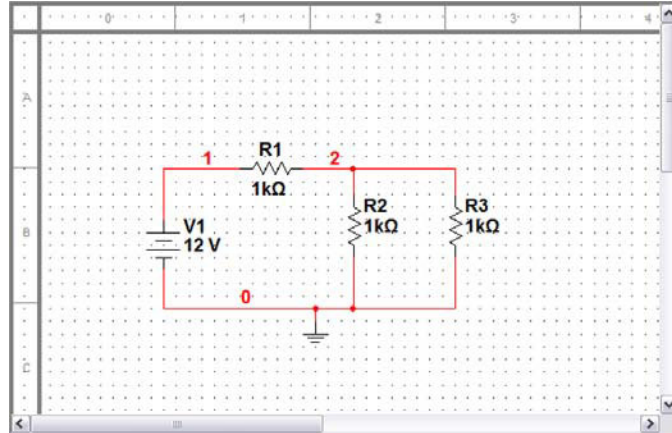

Figure 2.6: Resistive circuit.

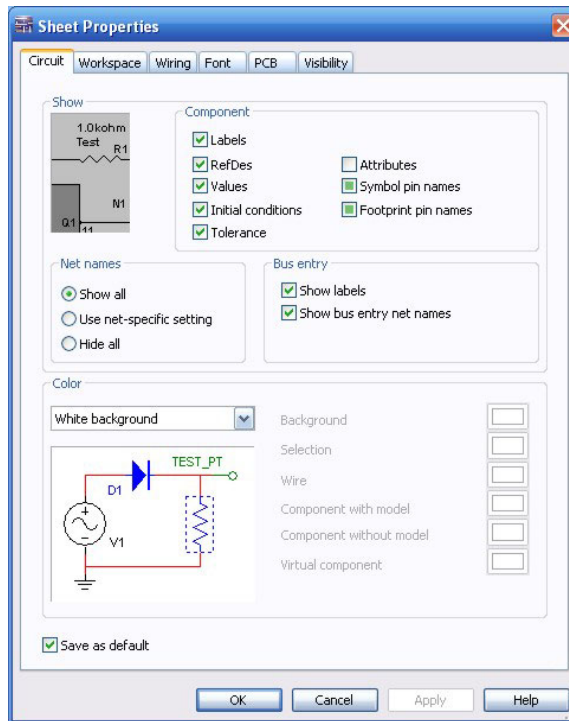

Figure 2.7: Dialog window for displaying node numbers on the schematic diagram.

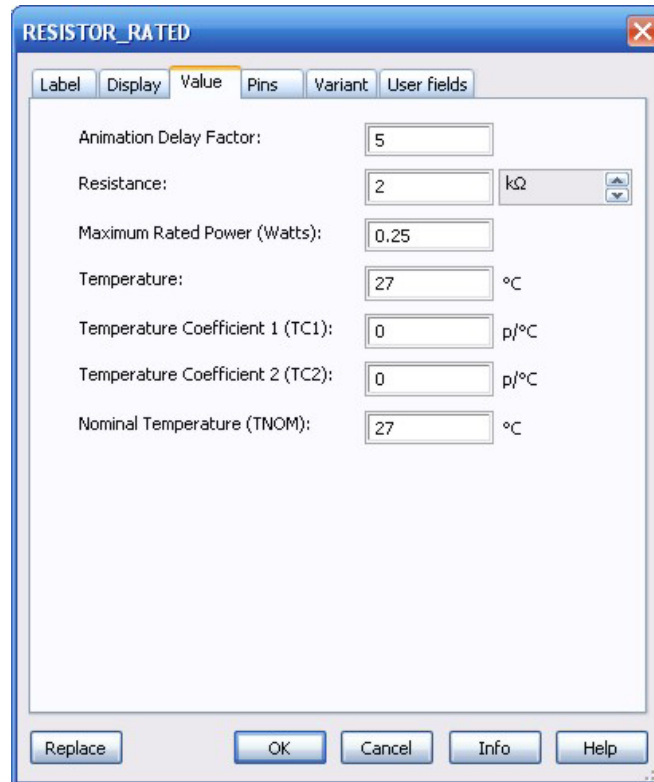

Figure 2.8: Window to change the value of resistor R1.

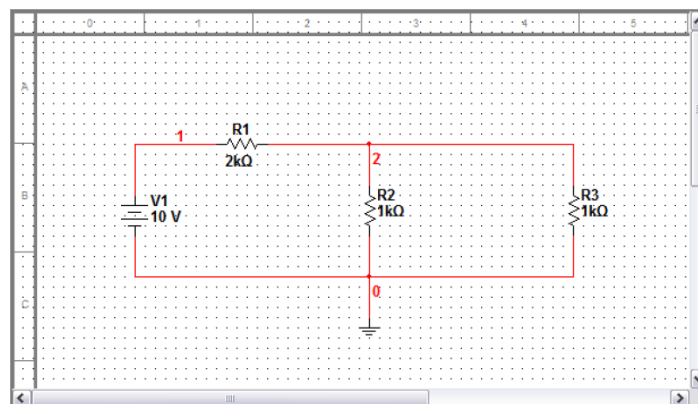

Figure 2.9: Final circuit in Multisim.

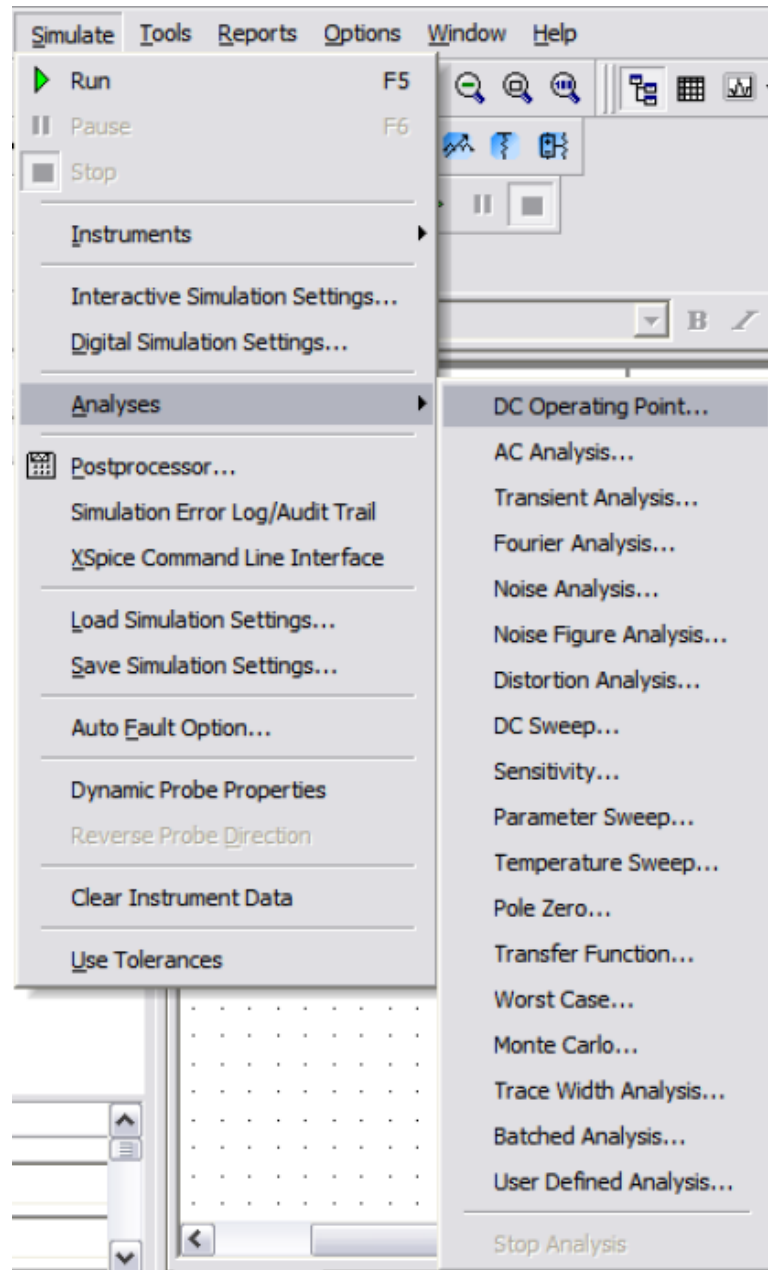

Figure 2.10: Choosing the DC Operating Point Analysis.



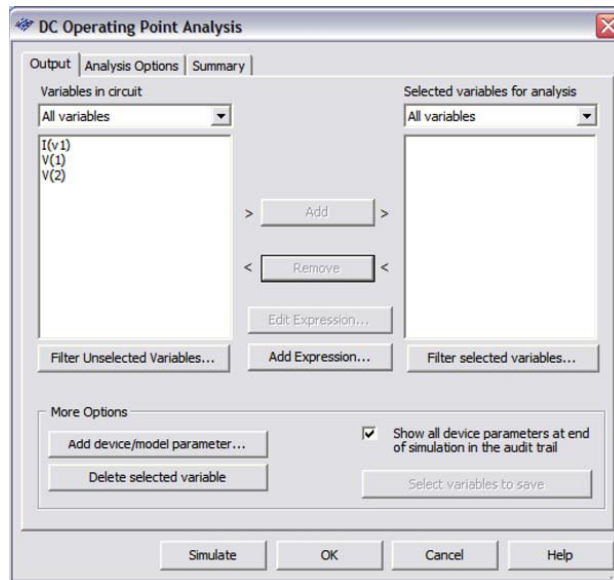

Figure 2.11: Window to choose the variables to display.

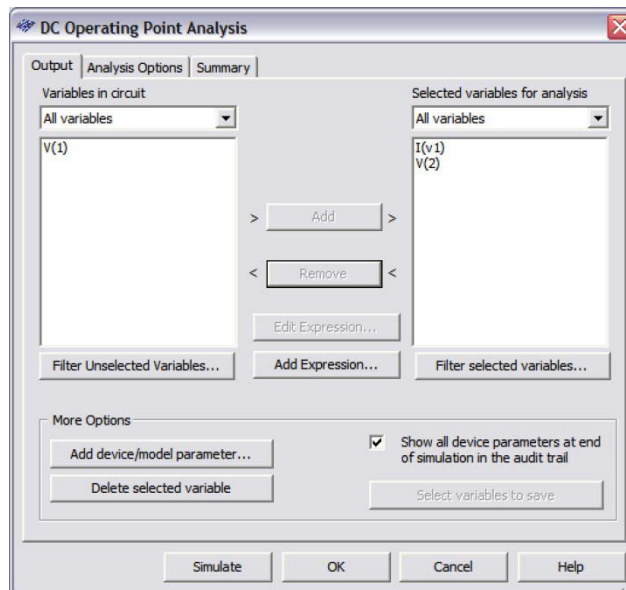

Figure 2.12: Variables to be displayed after the analysis.

## 12 2. RESISTIVE CIRCUITS

press the Add button. The variables selected are now displayed in the right window (see Fig. 2.12). Now press the Simulate button and after the analysis is run, Multisim displays the values of the variables selected before I(v1) and V(2) shown in Fig. 2.13. There we see that the current through the voltage source is -4 mA, indicating that the current is leaving the positive terminal in the voltage source, and that the voltage at node 2 is 2 volts.

## 2.2 MULTISIM MEASUREMENT INSTRUMENTS

Multisim provides a set of instruments that can be positioned in the circuit diagram to make measurements. These instruments can be used to measure voltages, currents, resistance and dB, among other more advanced measurements that we will cover along the book.

### 2.2.1 BASIC MEASUREMENT INSTRUMENTS

The first type of measurement instruments we cover are the voltmeter and the ammeter. These instruments are available in the Indicator icon in the Components toolbar. If we click on this icon we obtain the window of Fig. 2.14. Here, we have selected the VOLTMETER set. The voltmeters are shown in Fig. 2.15. We see that there are four choices. All of them are voltmeters and the only difference is the position of the pins and the positive input. VOLTMETER\_H has the pins along the horizontal position with the + input in the left-hand side. VOLTMETER\_HR has the + input in the right-hand side. VOLTMETER\_V has the input pins in a vertical position with the + input on top of the instrument whereas VOLTMETER\_VR has the + input in the bottom of the instrument. Associated with these voltmeters there is associated a resistance which is the internal resistance of them. An ideal voltmeter has associated an infinite resistance but a real one has a finite resistance. Multisim voltmeters have the default value of  $10\text{M}\Omega$  but this can be changed by double clicking on the voltmeter and changing the resistance in the tab Value shown in Fig. 2.16. For the time being, we leave the  $10\text{M}\Omega$  value unchanged and proceed to add voltmeters to the circuit of Example of Fig. 2.1 as can be seen in Fig. 2.17. Now we run the simulation with the Run icon or with the Run button, both seen in Fig. 2.18.

After using any one of the Run options, after a few moments (after the values are shown in the voltmeter window, we can stop the simulation by clicking on the Stop icon located next to the Run icon) we can see the voltages across resistors R1 and R2, which are 8 V and 2 V, respectively, as shown in Fig. 2.19.

The voltage across R2 is the voltage at node 2 obtained in Section 2.2.1. The voltage across R1 is the difference of the node voltages 1 and 2 which at Section 2.1.1 were found as 10V and 2V, respectively. Thus, the voltage across R1 is  $10 - 2 = 8\text{V}$  as obtained with the voltmeter.

The other type of measurement instrument that can be used is the ammeter. Ammeters are also available in the Indicator set. An ammeter has to be inserted in the circuit. Thus, if we wish to measure the current across resistors R1 and R3, we have to insert them in the circuit as can be seen in Fig. 2.20.

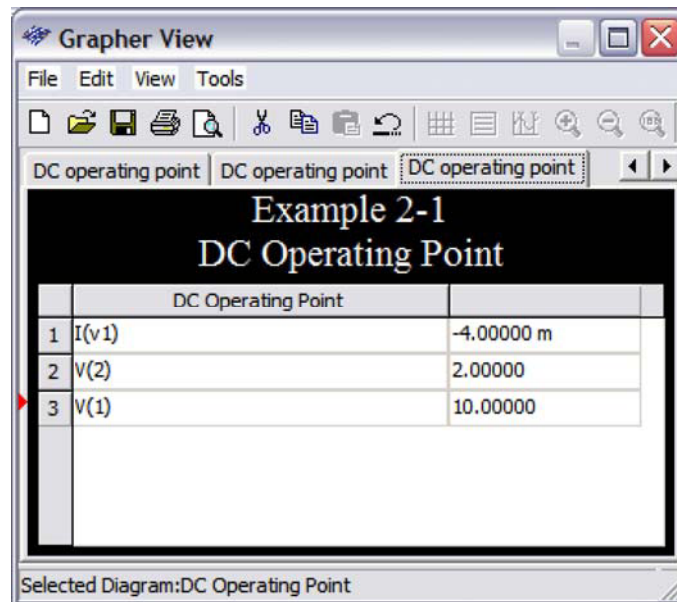

Figure 2.13: Values of the variables chosen in Fig. 2.12.

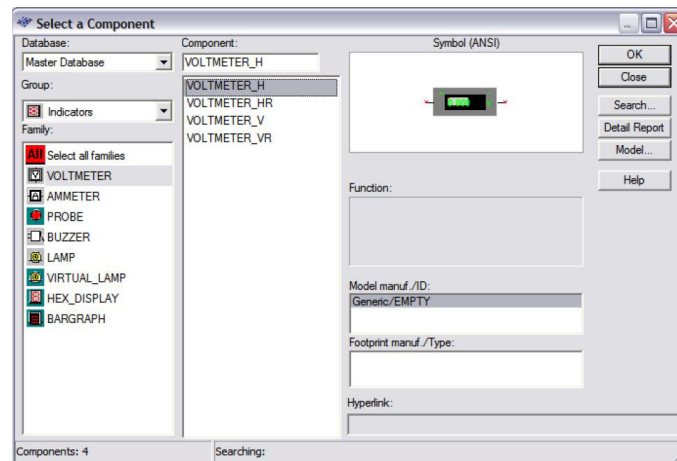

Figure 2.14: Window to select a voltmeter in the indicators window.

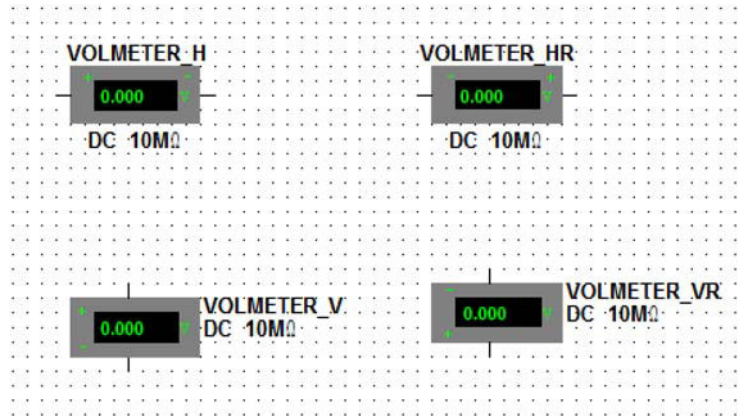

Figure 2.15: Voltmeters from the Indicator icon.

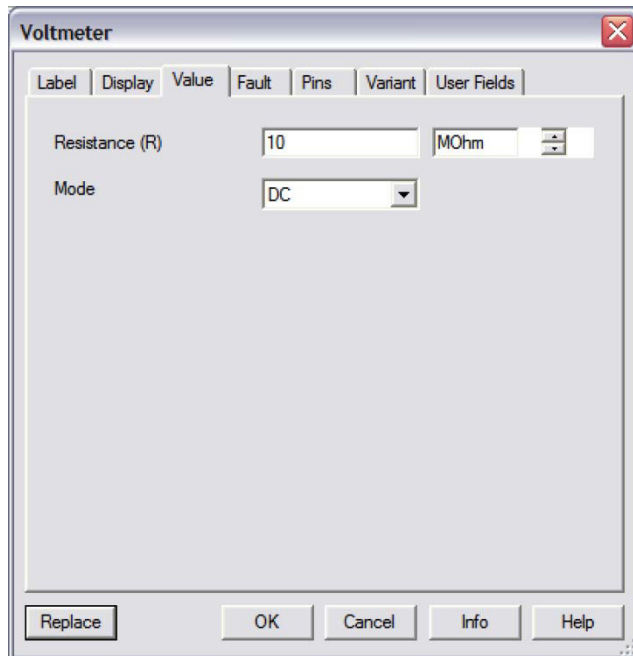

Figure 2.16: Internal resistance of a voltmeter.

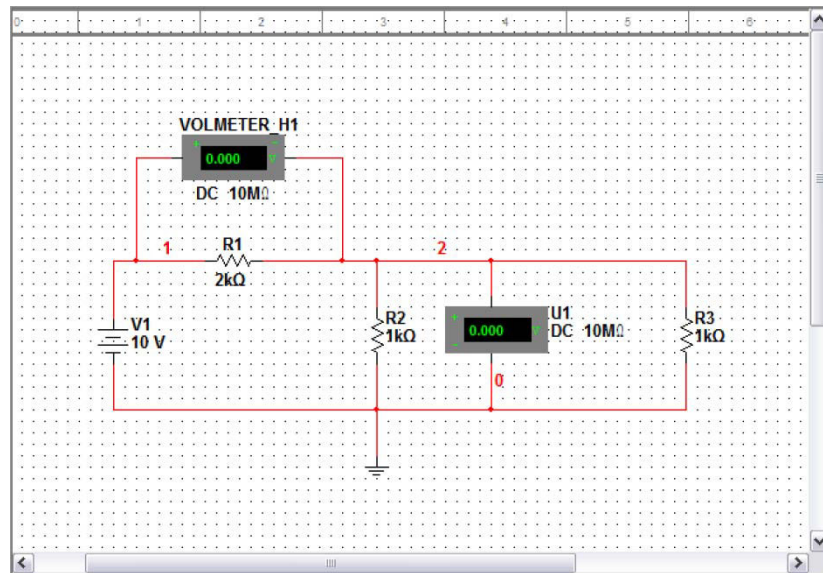

Figure 2.17: Circuit with Voltmeters added.

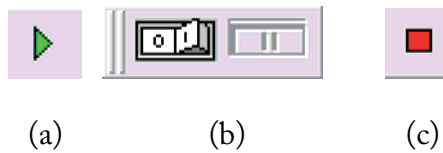

Figure 2.18: (a) Run icon, (b) Run button, and (c) Stop icon.

16 2. RESISTIVE CIRCUITS

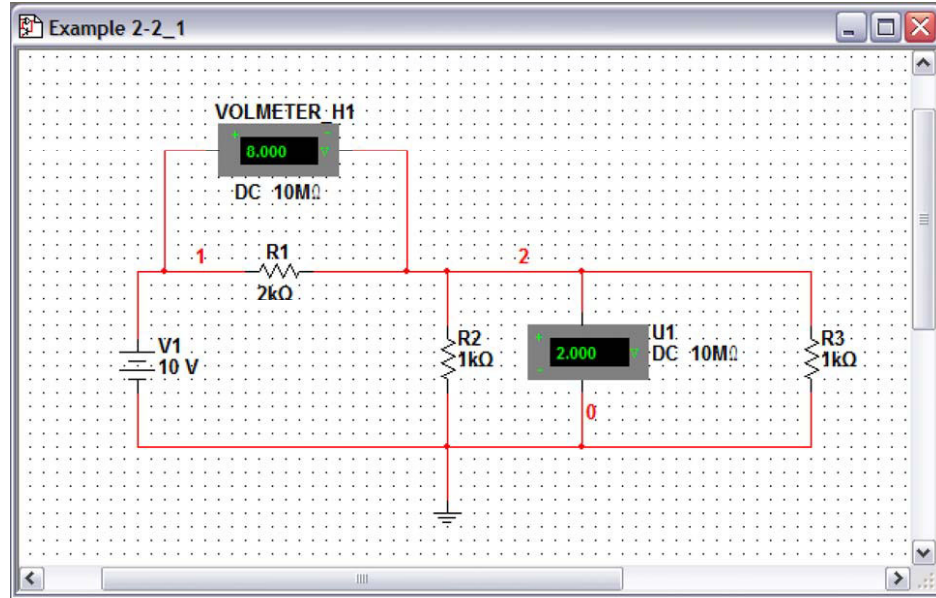

Figure 2.19: Measured voltages with Voltmeters.

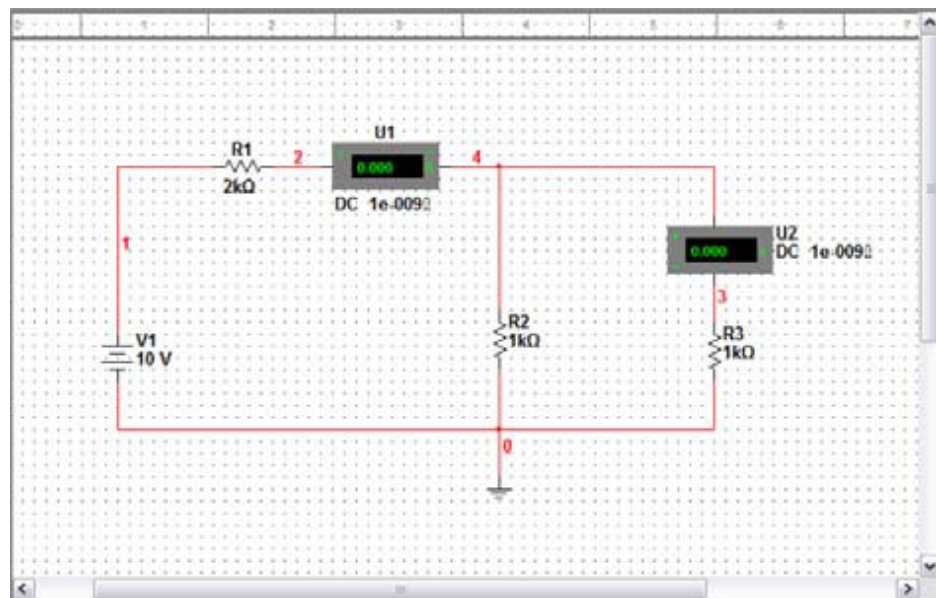

Figure 2.20: Circuit with ammeters.

An ideal ammeter has a zero internal resistance. A real one has a very small associated resistance. The ammeters provided by Multisim have a very small associated resistance whose value is  $1 \text{ n}\Omega$ . This resistance can be changed in the Value tab of the ammeter which opens by double clicking on the ammeter element in the schematic diagram. We run the simulation by using the Run icon or the Run button of Fig. 2.18 and after a few moments the values of the currents are displayed (see Fig. 2.21).

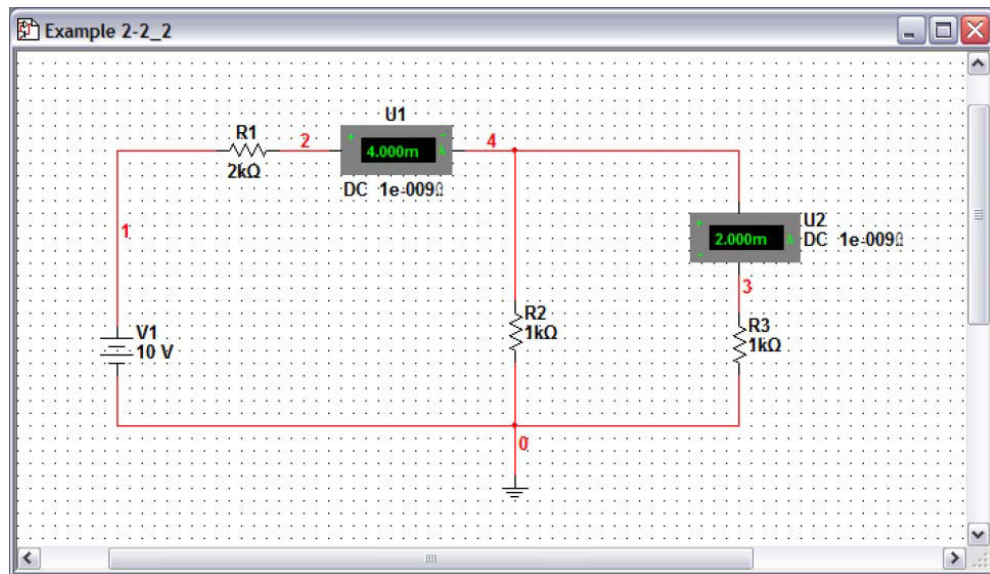

Figure 2.21: Current measurement using ammeters.

### 2.2.2 THE MULTIMETER

Besides the voltmeter and ammeter just discussed, there is another instrument to measure voltage, current, resistance, and dBs. It is available in the Instruments toolbar of Fig. 2.22. The first one of the instruments is a Multimeter. When we click on the Multimeter icon and one of them is displayed on the circuit diagram (see Fig. 2.23 (a)). When we double click on the Multimeter symbol we get a window (see Fig. 2.23 (b)) where we choose the type of signal: DC or AC, and in addition we choose the variable we wish to measure: A for amperes, V for volts,  $\Omega$  for resistance, or dB for decibels.

For the circuit we have been using, we place two multimeters, one to measure the voltage across R3 and another one to measure the current through R1. The circuit is shown in Fig. 2.24.

We run the simulation in the same way as before by clicking on the Run icon and after a few seconds we obtain the result shown in Fig. 2.25. The results agree with those obtained previously with the Voltmeter and Ammeter.





Figure 2.22: Instruments toolbar.

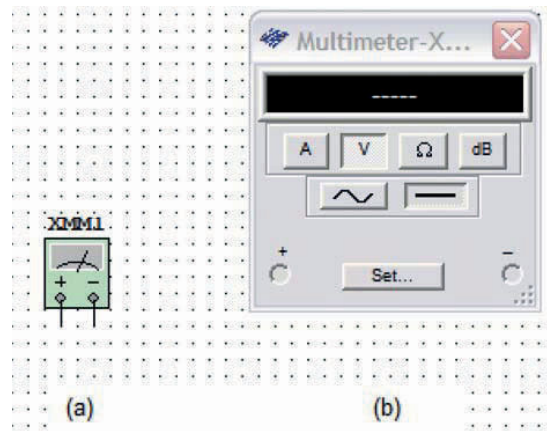

Figure 2.23: (a) Multimeter symbol and (b) Dialog window to choose the function.

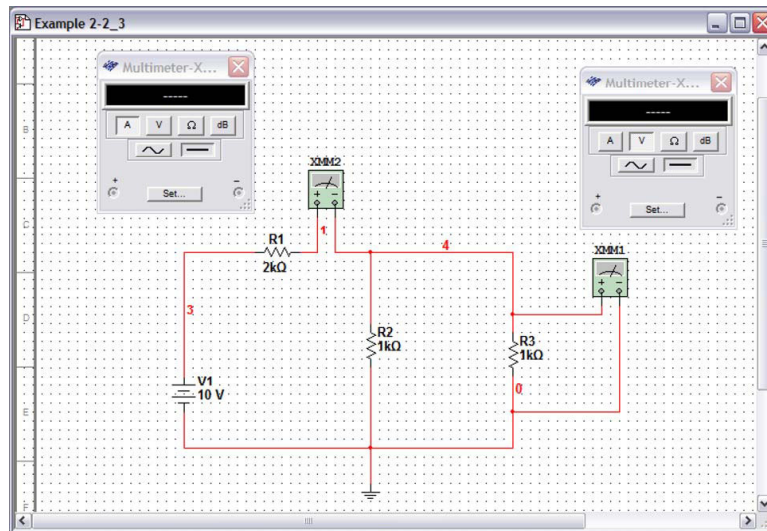
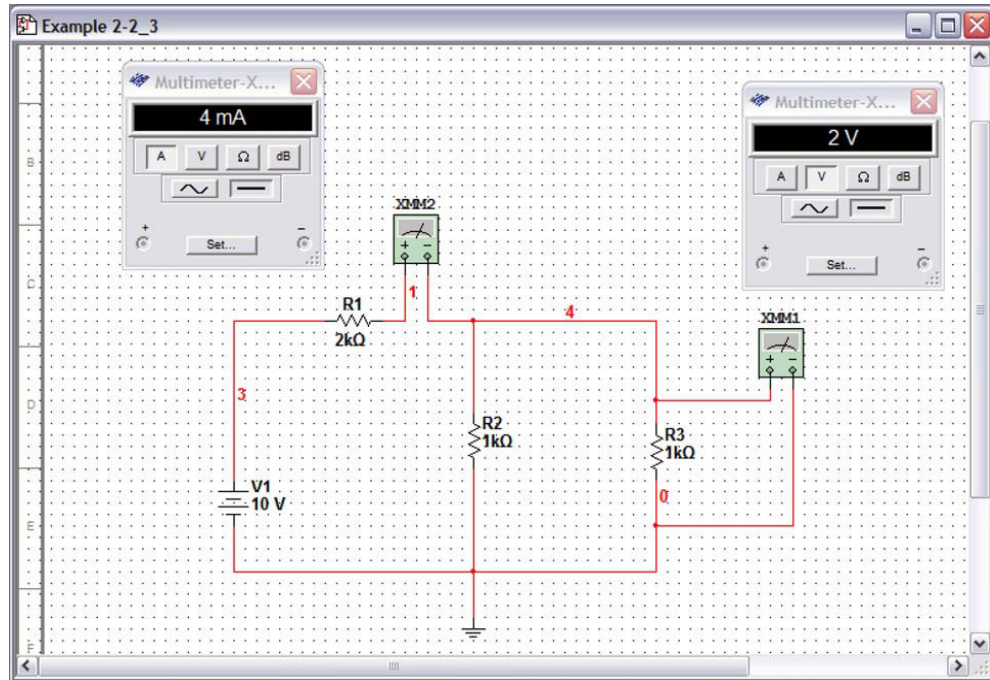

Figure 2.24: Circuit with multimeters to measure current and voltage.





**Figure 2.25:** Measured current and voltage with Multimeters.

The measurement of resistance follows the same format as before and a measurement is shown in Fig. 2.26. In this case, as it is in a real lab, we do not need to have a power supply but we also have to click on the Run button to measure resistance.

### 2.2.3 THE OSCILLOSCOPE

A powerful instrument from the Instruments toolbar is the Oscilloscope. This instrument allows us to see the signals waveforms. In this chapter we have only used DC signals, however, when we use AC signals, this instrument is very useful. To see how the oscilloscope can be used let us consider the circuit of Fig. 2.27. This circuit is a simple resistive voltage divider excited by a voltage sine wave (available as an AC voltage source). After wiring up the circuit use the run button and open the oscilloscope window by pressing the oscilloscope icon on the schematic diagram. We see the sine wave moving as in a real oscilloscope.

The oscilloscope is internally connected to the ground node so it is not necessary to connect the negative inputs to ground. The oscilloscope has a time base that can be adjusted for a proper display of the signals. It also has two input Scales, A and B, that can be adjusted for a better visualization of the signals. The scales for channels A, B, and the time base can be adjusted by left clicking on

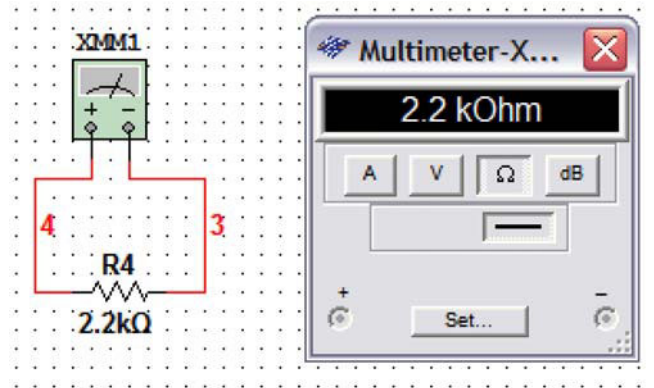

Figure 2.26: Measurement of resistance.

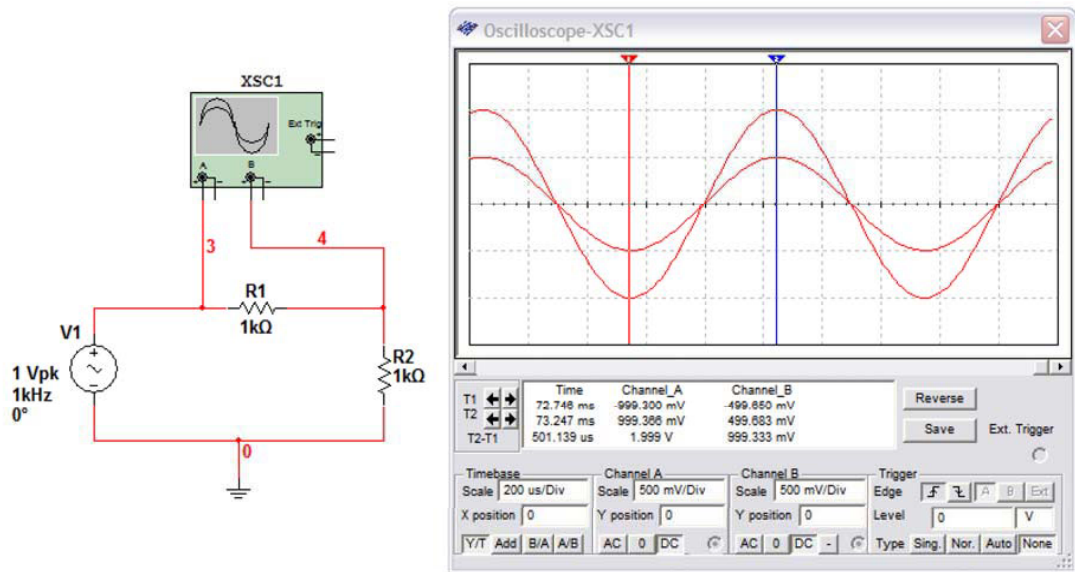
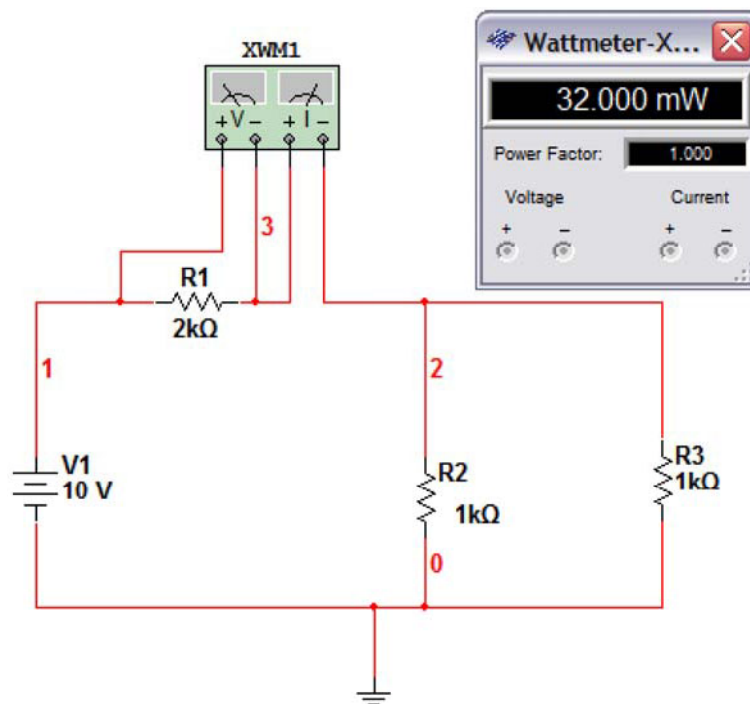

Figure 2.27: Voltage measurement using an oscilloscope.

the Scale spaces. There also two cursors that can be positioned with the mouse for proper signal amplitude measurements.

### 2.2.4 THE WATTMETER

The Wattmeter is available in the Instruments toolbar and it is used to measure power dissipation in a device. It measures current and voltage and calculates the product of them to compute power. This instrument has an ammeter and a voltmeter that have to be properly connected. As an example we consider the circuit of Fig. 2.8 and we add a Wattmeter. The circuit is shown in Fig. 2.28. We can see that the power through resistor R1 is 32 mW. Unfortunately, the wattmeter does not work correctly in all Multisim versions, for example, version 11.0.2.



**Figure 2.28:** Power measurement using a Wattmeter.

### 2.2.5 THE PROBE

The last element in the Instruments toolbar is the Probe. This instrument can be used to measure voltage, current, and frequency for either a DC or an AC signal. To the circuit of Fig. 2.28 we add a

## 22 2. RESISTIVE CIRCUITS

Probe and run the simulation to obtain the results shown in Fig. 2.29. There we see that the voltage at that node is 2 VDC and that the current passing through that wire is 4 mA.

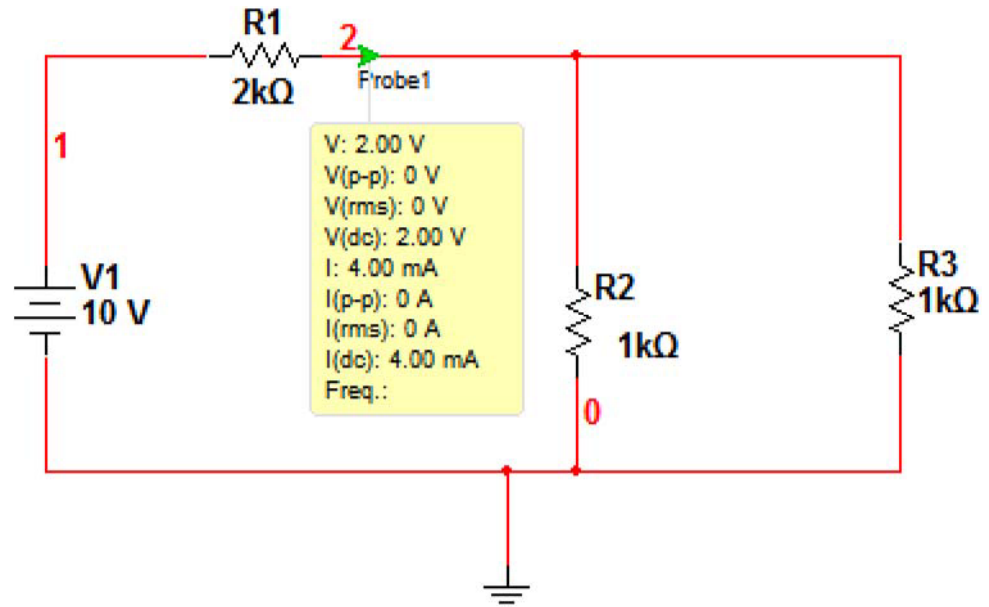

**Figure 2.29:** Measurement using a Probe.

## 2.3 BREADBOARD CIRCUIT CAPTURE

Multisim has the capability to wire a schematic on a breadboard in the same way we build the circuit on a breadboard. This feature enables novice simulation users to breadboard their schematic and to check if the circuit was correctly wired.

To use this Multisim feature, we click on the Show Breadboard icon of Fig. 2.30. This icon will produce the breadboard on the Multisim drawing space as can be seen in Fig. 2.31.

To use the breadboard we have first to draw a schematic diagram of the circuit. We show the procedure with a simple RC circuit.

### **Example 2.1 Simple RC circuit.**

Let us consider the circuit of Fig. 2.32, which is an RC circuit. As can be seen it is composed of an AC voltage source, a resistor, and a capacitor. We have added a ground symbol to comply with the need of having it for the simulation. Now we click on the Show Breadboard icon to obtain the breadboard view, shown in Fig. 2.33. Here we see an empty breadboard with all the components



**Figure 2.30:** Icon to switch to breadboard wiring.

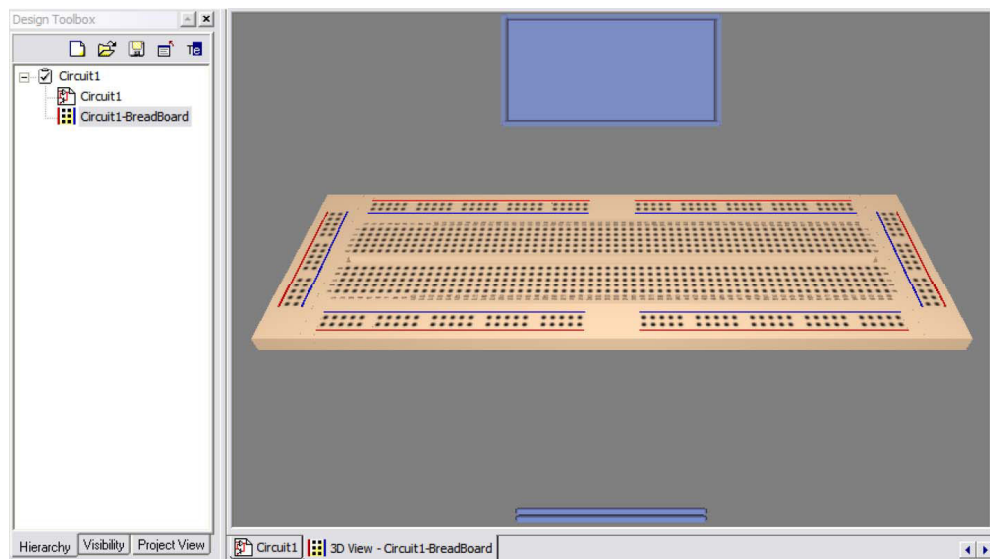

**Figure 2.31:** Breadboard view.

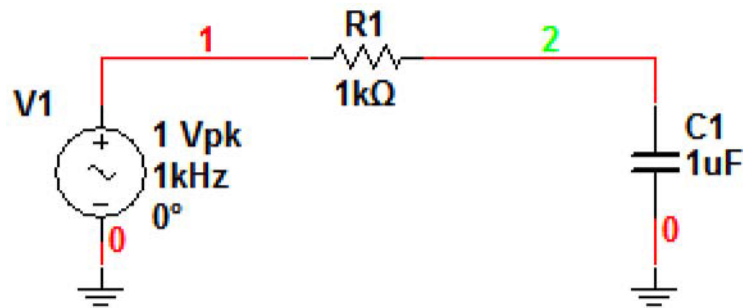

**Figure 2.32:** Simple RC circuit.

## 24 2. RESISTIVE CIRCUITS

located on the blue tray on the bottom on the figure. The green arrows at both ends of the blue tray are used to scroll the components.

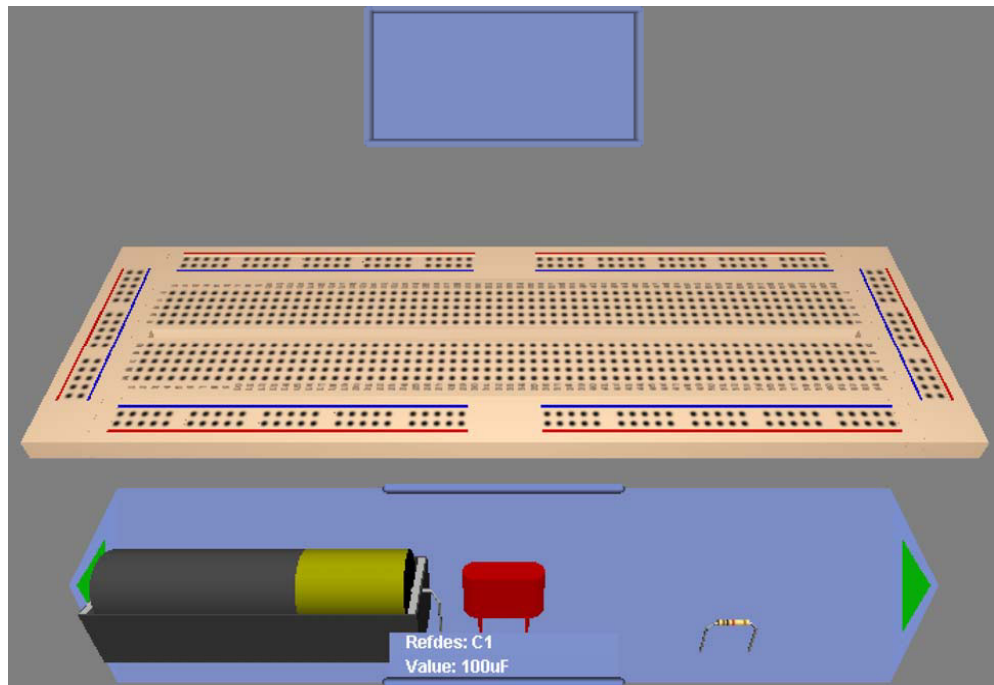

**Figure 2.33:** Empty breadboard with components on the blue tray.

To place the components on the breadboard we click on any of them and place it on the breadboard. We place the three components on the breadboard as shown in Fig. 2.34. If we need to rotate them to place them in the required position we right click on the component and select Orientation → 90 Clockwise (or 90 Counter CW). If we go back to the schematic drawing we see that the three components have turned green. This means that they are on the breadboard. Now on the breadboard we wire up the circuit as required. To place a wire we left click on a point in the breadboard and move the cursor to the other point where we wish to place the wire as can be seen in Fig. 2.35. We repeat this procedure until we are finished wiring. The finished circuit is shown in Fig. 2.36. To check if we wired it correctly, we go back to the schematic drawing and note that the circuit elements and connections are now green indicating that the breadboard circuit was wired up correctly. If there are wrong connections, these connections will remain in red.

Another way to check for connectivity is to use the DRC and Connectivity tool from the Tools menu. It will produce an output as shown in Fig. 2.37. We see there that there are no connectivity errors.



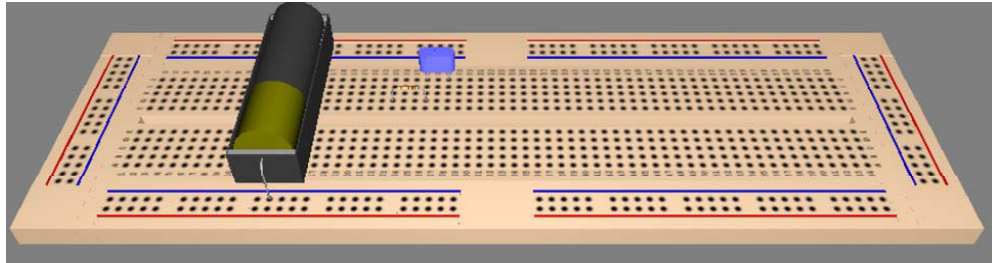

Figure 2.34: Elements on the breadboard.

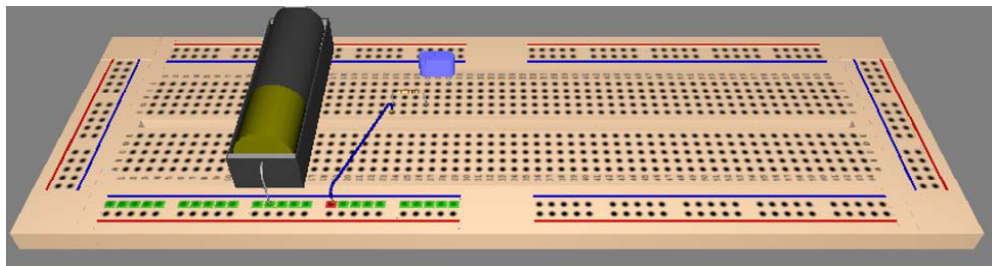

Figure 2.35: Connecting a wire.

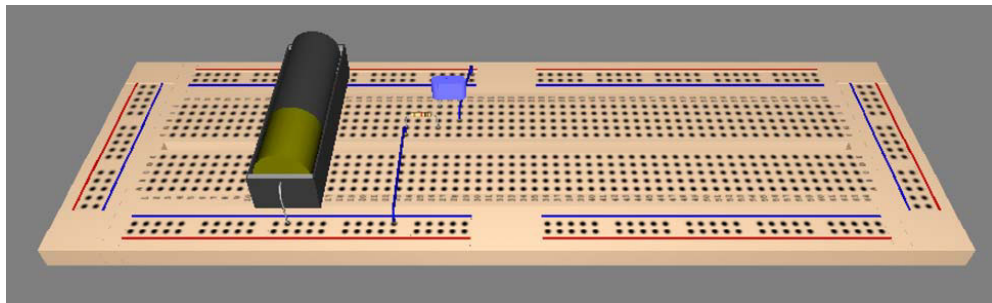

Figure 2.36: Final circuit.

```
Multisim - 2008-06-19 13:35:48

---Design Rule Check---
---0 Design Rule Errors Found---

---Connectivity Check---
---0 Connectivity Errors Found---
```

**Figure 2.37:** Checking the connectivity of the circuit.

### 2.3.1 THREE DIMENSIONAL VIRTUAL COMPONENTS

Multisim Educational license has the capability to draw pictorial diagrams and then simulate them. To do this, Multisim has a three-dimensional set of elements called 3\_D VIRTUAL within the Basic group. It has resistors, capacitors, inductors, diodes, transistors, among another few components, as can be seen in Fig. 2.38. An example shows how we can use this feature.

#### **Example 2.2 Common emitter amplifier.**

The circuit shown in Fig. 2.39 is a common emitter amplifier using a bipolar transistor. We now draw a pictorial representation using the 3\_D VIRTUAL group of components. Fig. 2.40 is the common emitter amplifier using the 3\_D components. Transistor pins can be obtained from manufacturer data sheets, in this case for the bipolar transistor, the pins are ordered from left to right as EBC (emitter-base-collector). We perform a transient analysis and the input and output waveforms are shown in Fig. 2.41. We note a small gain in the amplifier in addition to a  $180^\circ$  phase shift.

## 2.4 USE OF THE MULTISIM GRAPHER

Multisim can display results of a simulation in its powerful Grapher. Results of any analysis, with exception of the DC Operating Point one, can be plotted in the Grapher. To show how the Grapher works let us use again the circuit of Fig. 2.1, but we now perform a DC Sweep Analysis, so we select Simulate  $\rightarrow$  Analyses  $\rightarrow$  DC Sweep to open the dialog window of Fig. 2.42 (a). There we select the source V1 that it is going to be swept. We also give the Start value of 10 V, Stop value of 100 V, and an Increment of 5 V. In the Output tab (see Fig. 2.42 (b)) we select the output variable, in this example we choose the voltage at node 2, V(2). We then press the Simulate button. The results are displayed in Fig. 2.43. There we see that the voltage at node 2 changes from 2 V to 20 V when the DC voltage source changes from 10 V to 100 V.



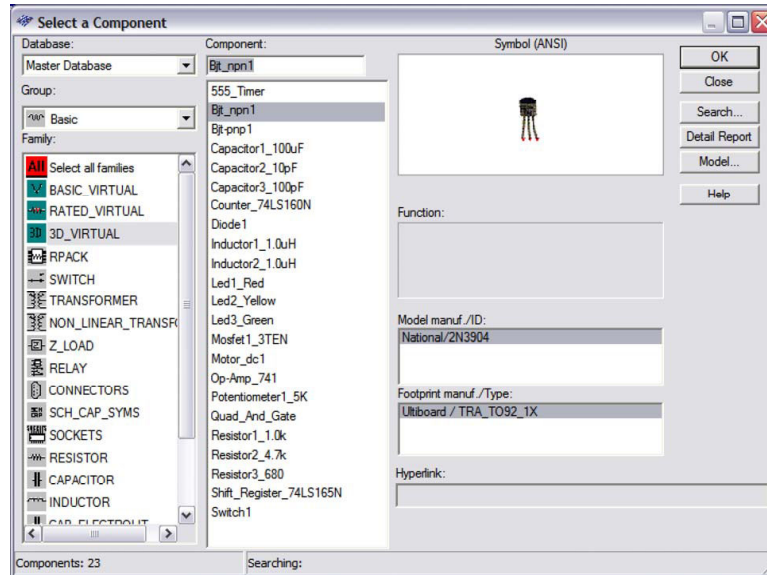

**Figure 2.38:** Components in the 3\_D VIRTUAL set within the Basic group. A npn BJT is shown in the symbol window.

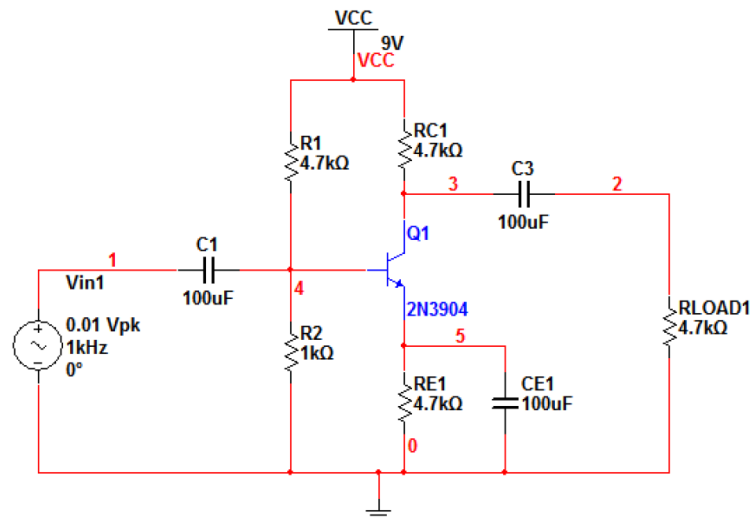

**Figure 2.39:** Common emitter amplifier.

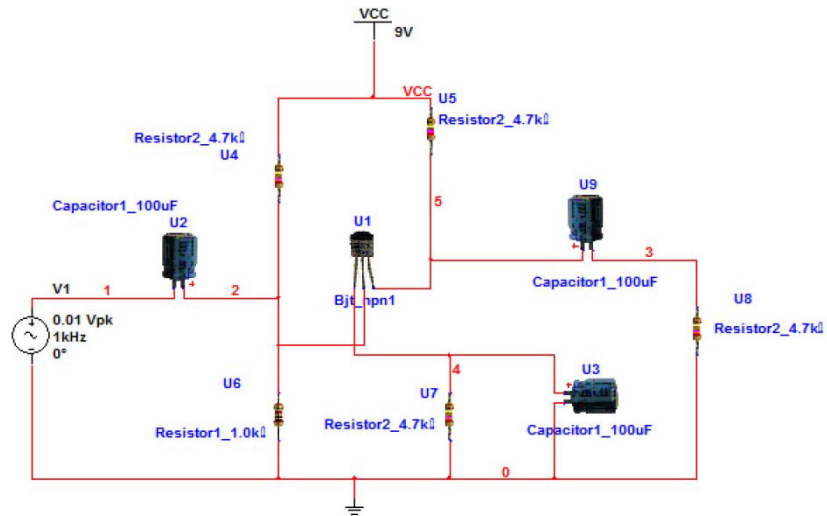

Figure 2.40: Pictorial diagram of the common emitter amplifier.

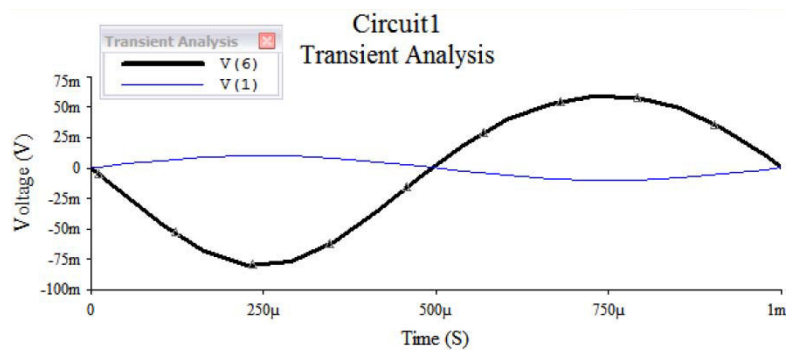
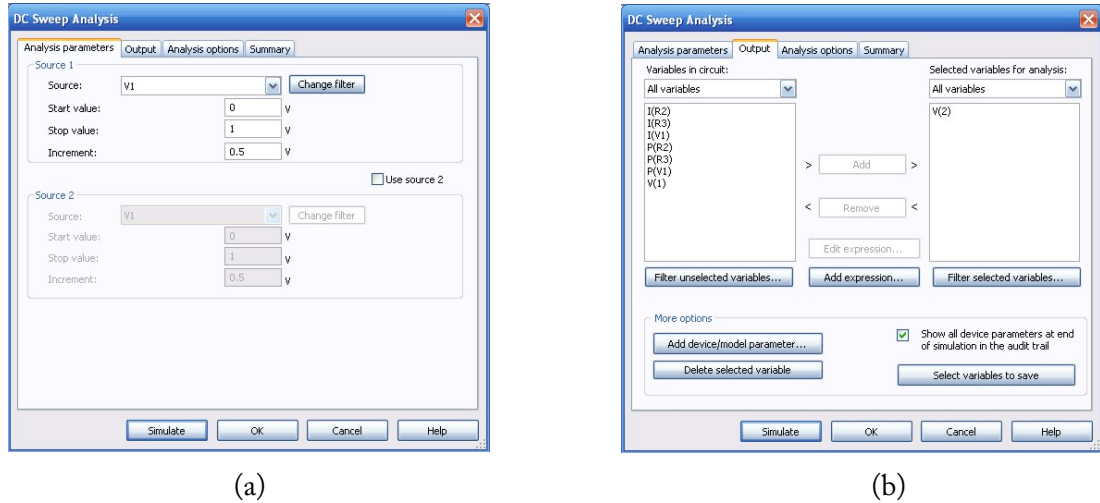

Figure 2.41: Transient response. There is a small gain from input to output.



**Figure 2.42:** (a) Specification of the sweep parameters, (b) Selection of output variables to sweep.

## 2.5 CIRCUITS WITH CONTROLLED SOURCES

Some devices, such as transistors and operational amplifiers, are modeled by equivalent circuits consisting, among other elements, by controlled sources. Multisim has four types of controlled sources available. They are:

1. E Voltage controlled voltage source VCVS
2. F Current controlled current source ICIS
3. G Voltage controlled current source VCIS
4. H Current controlled voltage source ICVS

The letters E, F, G, and H are used to represent each source type.

### 2.5.1 CIRCUITS WITH VCVS

A VCVS has a value controlled by a voltage between a pair of nodes, as shown in Fig. 2.44. The VCVS is available in Sources → CONTROLLED\_VOLTAGE\_SOURCES → VOLTAGE\_CONTROLLED\_VOLTAGE\_SOURCE. The VCVS available in Multisim is shown in Figure 2.45. The left element is to be positioned at the controlling nodes.

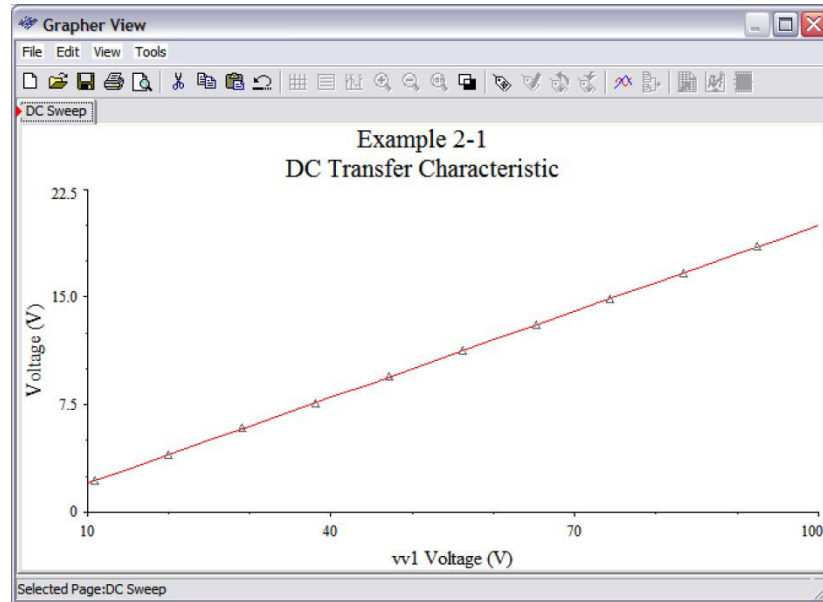

**Figure 2.43:** Voltage sweep for V(2).

### Example 2.3 Circuit with VCVS.

As an example consider the circuit of Fig. 2.46. This circuit is composed by an independent DC voltage source with a value of 10 v, three resistors, and a VCVS whose voltage is 7 times the voltage drop across resistor R2. The value for the VCVS can be given by double clicking on the symbol of the VCVS and assigning the value of 7 as shown in Fig. 2.47. Fig. 2.48 shows the final circuit.

We make a DC Operating Point analysis by clicking on Simulate → Analyses → DC Operating Point. A window appears where we select the variables we wish to find out. We add all of them and press the Simulate button. Then, the circuit is simulated and a window showing the values of all the variables selected is displayed as shown in Fig. 2.49.

### 2.5.2 CIRCUITS WITH ICIS

The ICIS is a current source whose value depends upon the value of a current in other branch. The ICIS is available in Sources → CONTROLLED\_CURRENT\_SOURCES → CURRENT\_CONTROLLED\_CURRENT\_SOURCE. The Multisim symbol is shown in Fig. 2.50. The sensing element is located at the left side and it must be inserted in the circuit.

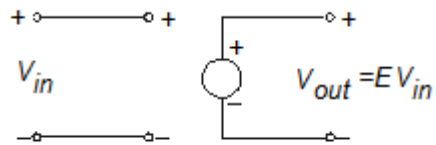

**Figure 2.44:** Model of the VCVS.

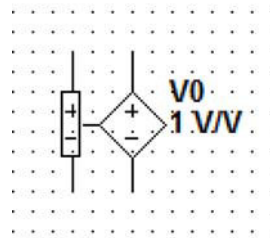

**Figure 2.45:** VCVS in Multisim. The left element is to be positioned at the controlling nodes.

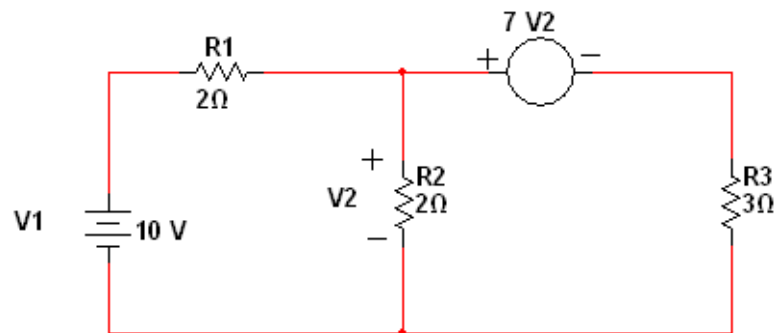

**Figure 2.46:** A circuit with a VCVS.



Figure 2.47: Window to assign the value of 7 to the VCVS.

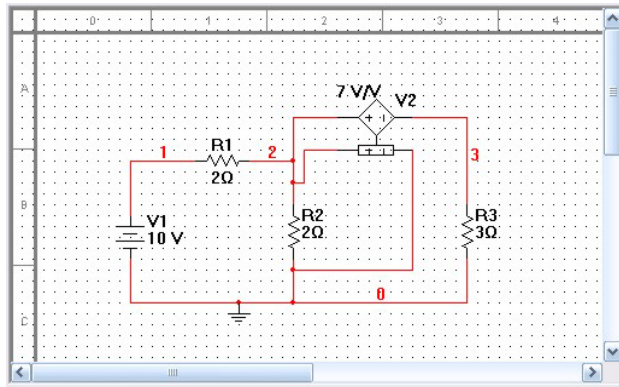
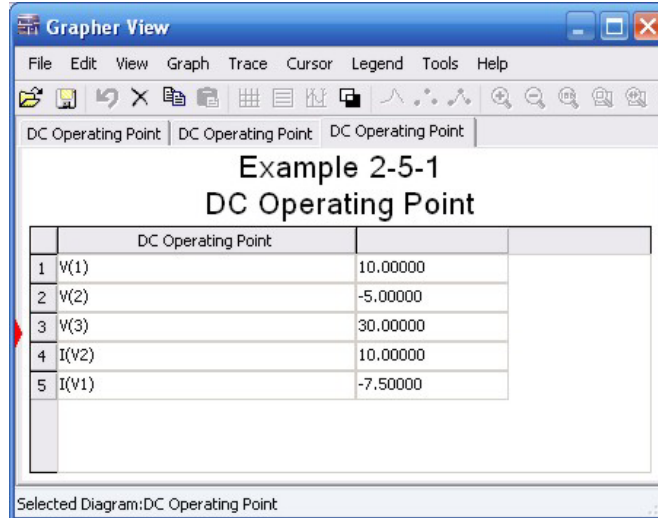
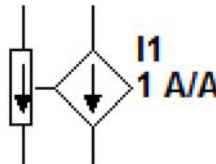

Figure 2.48: Circuit with a VCVS in Multisim.



DC Operating Point		
1	V(1)	10.00000
2	V(2)	-5.00000
3	V(3)	30.00000
4	I(V2)	10.00000
5	I(V1)	-7.50000

**Figure 2.49:** Values of the variables from the DC Operating Point analysis.



**Figure 2.50:** Multisim symbol for the ICIS.

#### Example 2.4 Circuit with an ICIS (F-source)

Let us consider the circuit in Fig. 2.51. This circuit is drawn in Multisim as shown in Fig. 2.52. Note that because of the controlling current is pointing downward, the sensing element has to be connected accordingly downward. As for the case of the E-source, we assign the value to the ICIS by double clicking on the F-source to obtain the window in Fig. 2.53 where we assign the value of 3. By clicking on Simulate → Analyses → DC Operating Point... a window is open where we select the variable to display. We select all of them and click the Simulate button. After the simulation is finished we see the window with the node voltages and the current through the DC voltage source shown in Fig. 2.53.

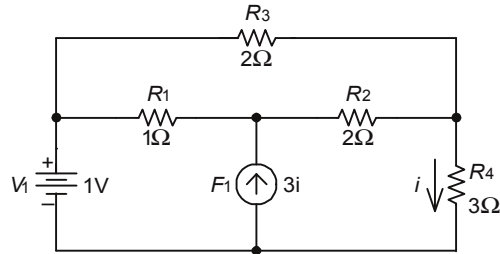

Figure 2.51: Resistive circuit with an ICIS (F-source).

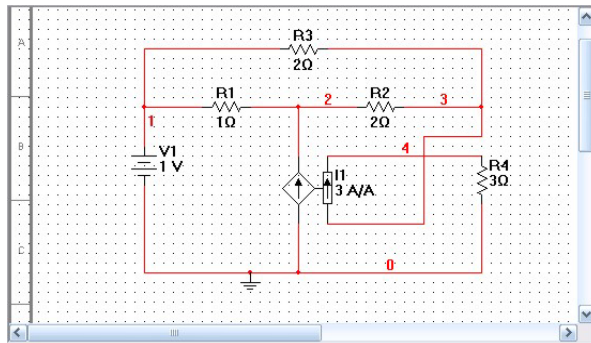

Figure 2.52: Resistive circuit with an ICIS in Multisim.

Grapher View

File Edit View Graph Trace Cursor Legend Tools Help

DC Operating Point | DC Operating Point | DC Operating Point | DC Operating Point

### Example 2-5-2

#### DC Operating Point

DC Operating Point		
1	V(1)	1.00000
2	V(2)	1.66667
3	V(3)	1.00000
4	I(V1)	666.66667 m
5	V(4)	1.00000

Selected Diagram: DC Operating Point

Figure 2.53: Output variables.



### 2.5.3 CIRCUITS WITH VCIS (G-SOURCE)

A voltage controlled current source is a current source whose current is controlled by a voltage drop in a pair of nodes. It is denoted in Multisim with a letter G, and thus it is also referred as a G-source. The Multisim symbol for a G-source is presented in Fig. 2.54. The VCIS is available in Sources → CONTROLLED\_CURRENT\_SOURCES → VOLTAGE\_CONTROLLED\_CURRENT\_SOURCE.

#### Example 2.5 Circuit with a G source.

The circuit in Fig. 2.55 has a VCIS. The Multisim circuit is shown in Fig. 2.56. Note that the signs in the sensing element and the controlling voltage must coincide. After doing a DC Operating Point analysis we obtain the voltage values given in Fig. 2.57.

### 2.5.4 CIRCUITS WITH ICVS (H-SOURCE)

Finally, the current controlled voltage source ICVS, denoted by the letter H, and thus called H-source. Its symbol is shown in Fig. 2.58. This is a controlled source whose voltage value is controlled by the current through another branch. The ICVS is available in Sources → CONTROLLED\_CURRENT\_SOURCES → VOLTAGE\_CONTROLLED\_CURRENT\_SOURCE.

#### Example 2.6 Resistive circuit with a ICVS.

The circuit of Fig. 2.59 has an H source. Its Multisim diagram is given in Fig. 2.60. A DC Operating Point analysis gives the node voltages and DC voltage source current shown in Fig. 2.61.

## 2.6 CONCLUSIONS

In this chapter we presented the first few circuits analyzed in Multisim. Although our circuits have been restricted to circuits containing resistors and independent and controlled sources, the main purpose of the chapter is to introduce the reader to the Multisim simulation environment. The analysis types in this chapter were DC Operating Point and DC Sweep analyses. We also introduced measurement instruments. They were used to measure voltage, current, and resistance. In the next chapters we will cover other types of analysis with circuits containing inductors, capacitors, transistors, etc. More interesting types of analysis can be performed in such cases.

## PROBLEMS

- 2.1. Obtain the dc currents in each element and node voltages of the circuit:



Figure 2.54: Multisim symbol of a VCIS.

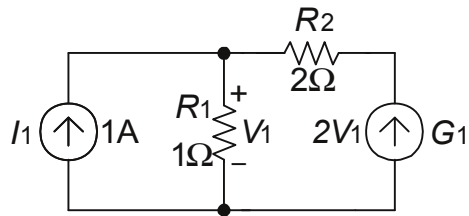

Figure 2.55: Resistive circuit with a VCIS.

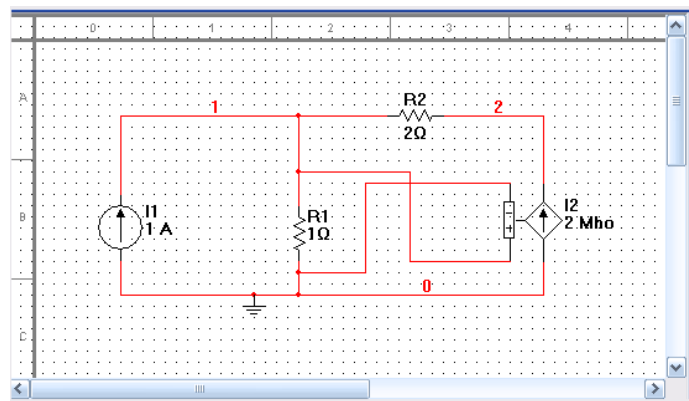

Figure 2.56: Resistive circuit with G-source in Multisim.

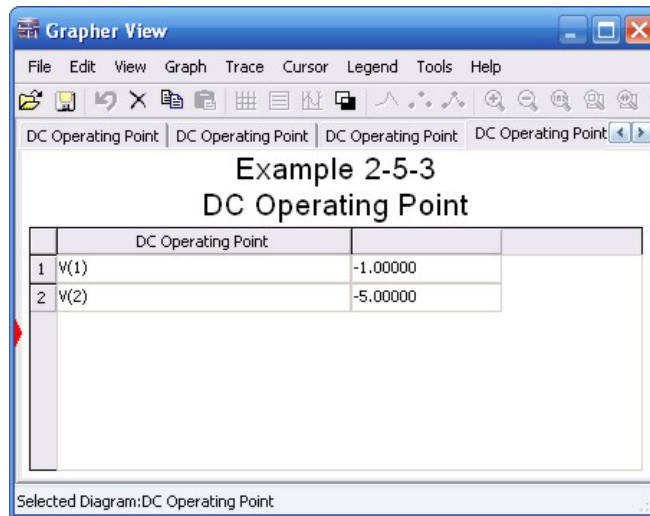

Figure 2.57: Voltage nodes for the G-source circuit.

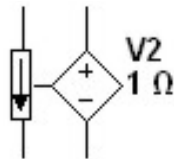

Figure 2.58: Multisim symbol for the ICVS or H-source.

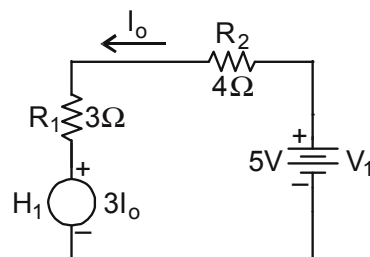

Figure 2.59: Circuit with a ICVS.

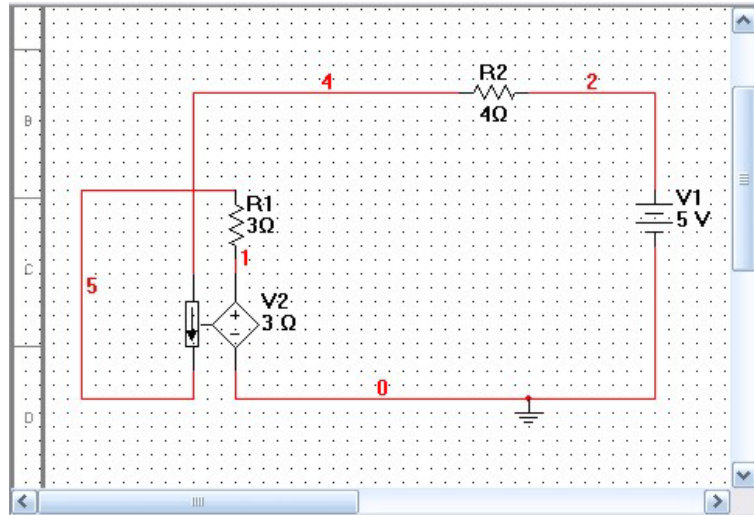
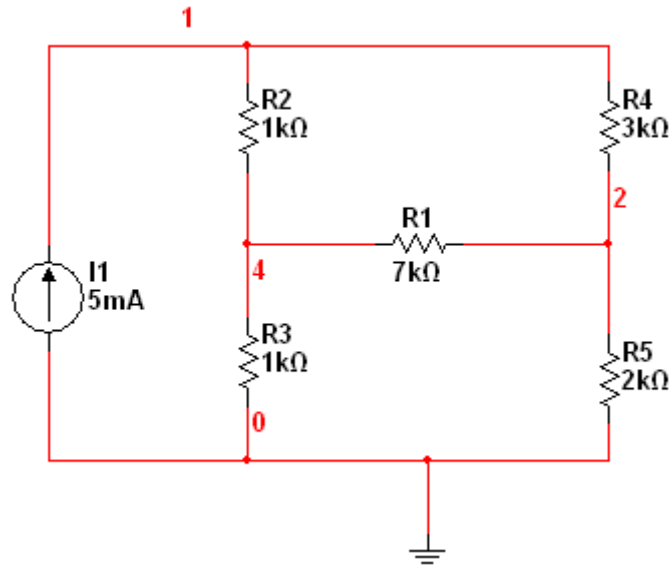

Figure 2.60: H-source circuit in Multisim.

The screenshot shows the Grapher View window with the following data:

Circuit ICVS DC Operating Point		
DC Operating Point		
1	V(1)	1.50000
2	V(2)	5.00000
3	V(4)	3.00000
4	I(V1)	-500.00000 m

Figure 2.61: Values of the node voltages.



- 2.2. Repeat Exercise 2.1 but this time: (a) insert ammeters for current measurement and voltmeters for node voltages, (b) Use multimeters to measure voltages and currents.
- 2.3. Using a multimeter, obtain the equivalent resistance between: (a) nodes 1 and ground, and (b) nodes 2 and 4.

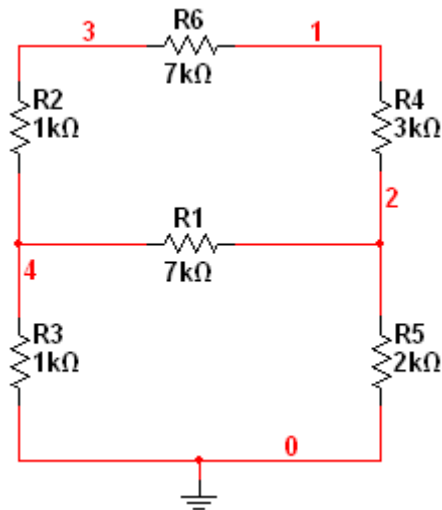

- 2.4. Using the breadboard, wire up the circuit shown. Then, obtain the dc node voltages and branch currents.

40 2. RESISTIVE CIRCUITS

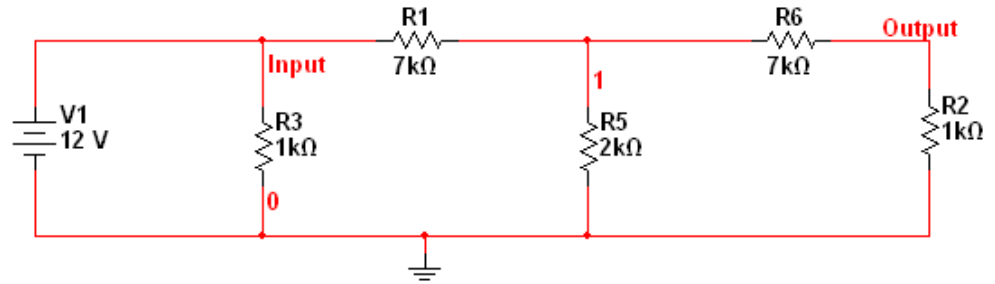

- 2.5. Change the dc voltage source V1 to an AC voltage source. Set the frequency to 1 KHz, the V1 RMS voltage to 1 volt. Use an oscilloscope to plot the input and output waveforms. At which scale we see the amplitude of the input voltage? And for the output voltage?
- 2.6. In the circuit shown we are using a virtual diode from the Diodes library. Use the oscilloscope and a probe to measure the peak voltage. Compare the peak voltage in both instruments and explain.

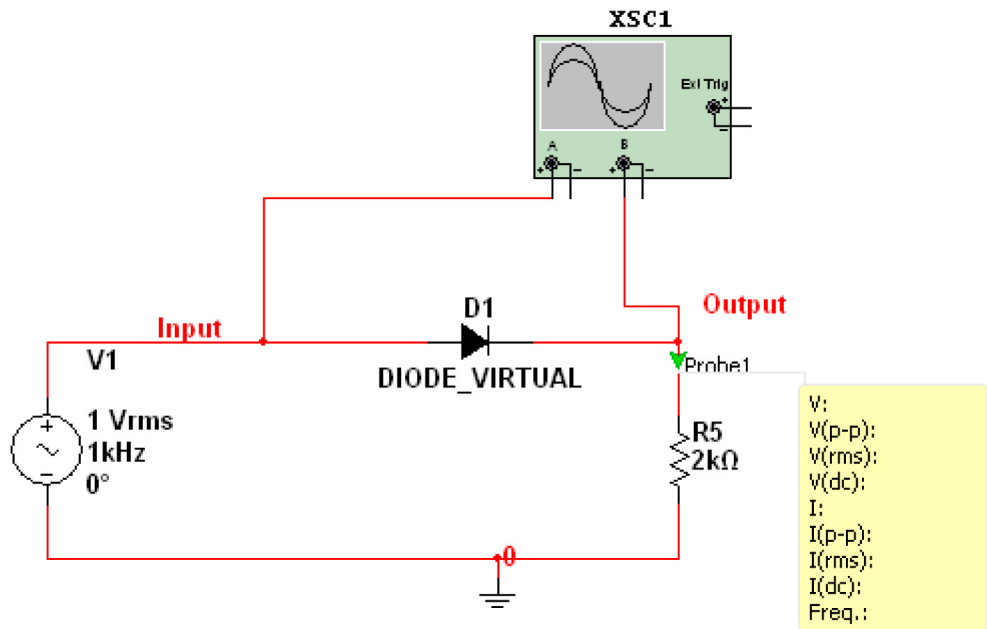

- 2.7. Draw the pictorial three-dimensional diagram of the circuit in Problem 2.6.
- 2.8. In the circuit shown, use the Multisim Grapher to obtain the waveforms in the input and output nodes.

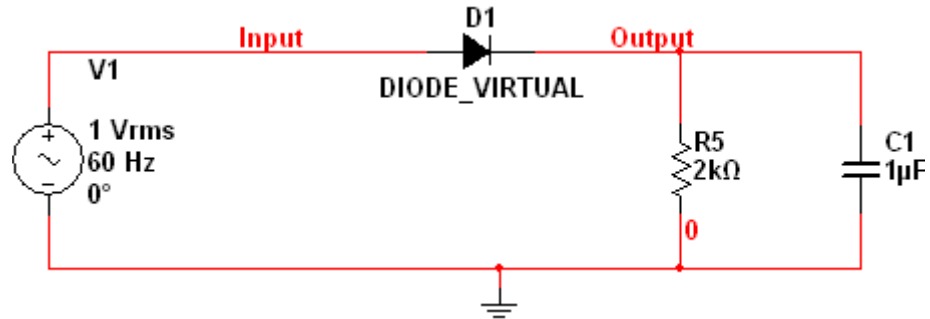

- 2.9. Use a VCVS in the circuit shown and obtain the node voltages. Note the signs in the controlling voltage  $V_x$ .

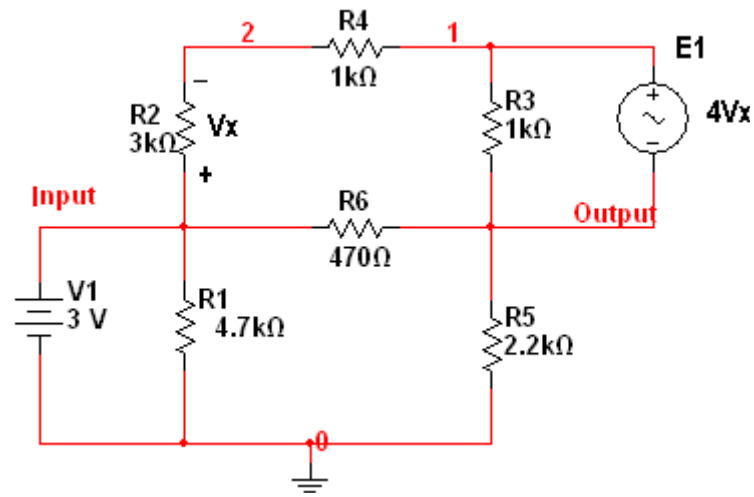

- 2.10. Use an ICIS to obtain node voltages.

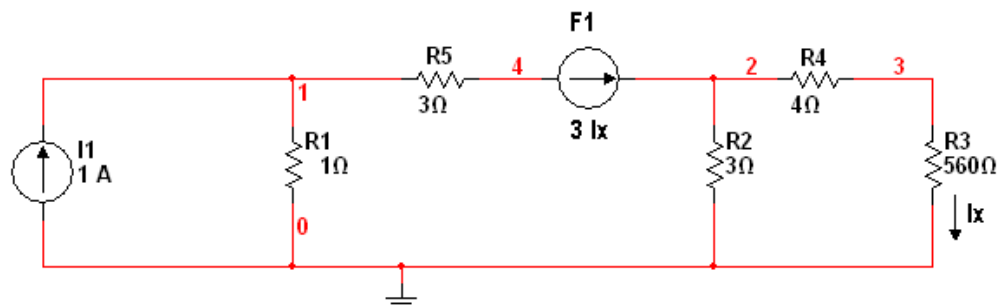

- 2.11. Use a VCIS in the circuit to obtain the branch currents.

42 2. RESISTIVE CIRCUITS

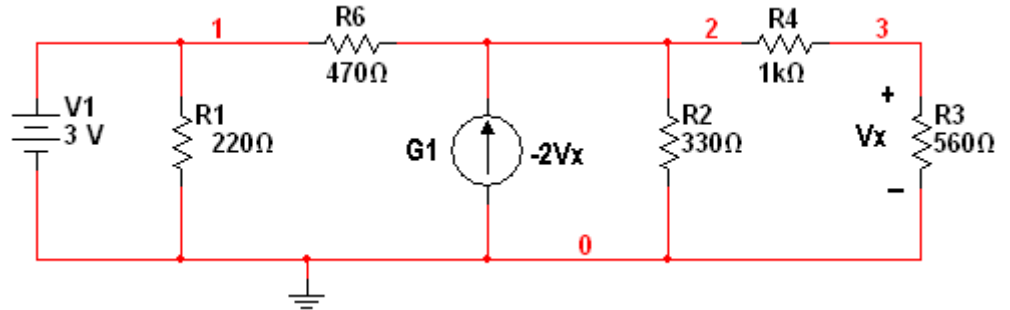

2.12. Use an ICVS to find the current through resistor R2.

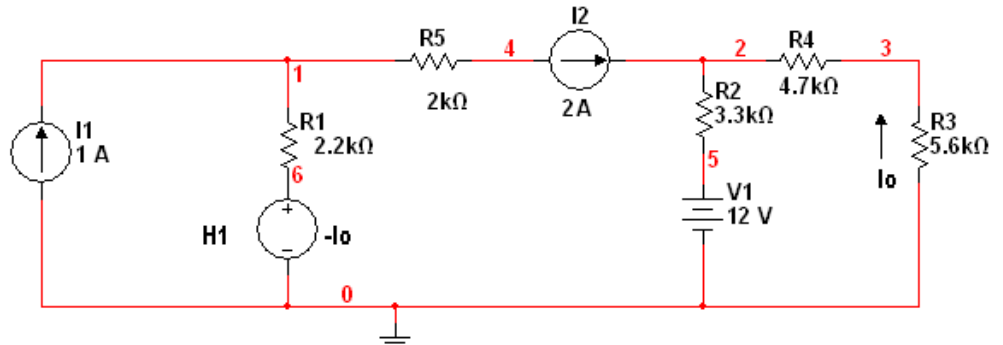



# Time Domain Analysis – Transient Analysis

One of the most useful analyses in electronic circuits is the transient analysis which is a time domain analysis. The purpose of this analysis is to apply a waveform to the circuit and observe its response versus time. Some of the parameters to watch are the overflow, rise time, delay, etc., depending upon the type of input signal. In this chapter we treat in detail how to perform a transient analysis. Furthermore, in this chapter we introduce capacitors and inductors, where the relationships between voltage and current are integro-differential equations. This fact makes that circuits composed of inductors and capacitors, besides resistors, have very interesting properties. In addition, the functions that these circuits can perform are quite varied and useful, when compared to resistive circuits.

The chapter is organized as follows. Section 3.1 begins with a description of capacitors and inductors. Section 3.2 describes the different input signals available for transient analysis. Section 3.3 is the heart of the chapter where transient analysis is explained. Fourier analysis is described in Section 3.5. Section 3.6 provides examples and Section 3.6 concludes the chapter.

## 3.1 CAPACITORS AND INDUCTORS

Capacitors and inductors are designated with the letters C and L, respectively. Their Multisim symbols are shown in Fig. 3.1. In this figure, electrolytic capacitors explicitly have a polarity. Non-electrolytic capacitors and inductors also have a polarity even though it is not shown in their schematic

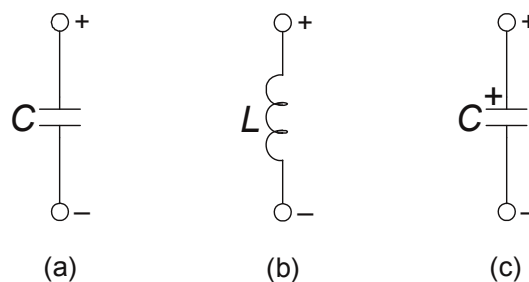

**Figure 3.1:** Schematic symbols for (a) capacitor, (b) inductor, and (c) electrolytic capacitor.

#### 44 3. TIME DOMAIN ANALYSIS – TRANSIENT ANALYSIS

symbol. This is only important when we apply an initial condition to these elements. As a rule, when we put any one of these components in a schematic, the left-hand node is the positive one. So if we rotate them, it is useful to watch where the positive node is moving to. To apply an initial condition we select the element (inductor or capacitor) to open its window where we write the initial condition value. Example 3.2 gives an example of this case. It is worth mentioning that for an inductor the initial condition is a current while for a capacitor it is a voltage. In addition, the use of initial conditions is only valid for transient analysis.

It is also possible to define coupled inductors in the form of transformers, transformers with a tap, and variable inductors and capacitors.

### 3.2 INPUT SIGNAL TYPES

There are several input signals that can be used in a transient analysis. They are:

Signal	Multisim name
exponential	EXPONENTIAL_TYPE
pulse	PULSE_TYPE
piecewise	PIECEWISE_LINEAR_TYPE
sine wave	AC_TYPE
FM sinewave	FM_TYPE
AM sinewave	AM_TYPE

Here, TYPE can be either VOLTAGE or CURRENT. For example, if we desire an AC voltage source then we choose an AC\_VOLTAGE source. Similarly, an exponential current source is EXPONENTIAL\_CURRENT.

Next, we give a description of each of these sources.

#### 3.2.1 EXPONENTIAL SIGNAL

The EXPONENTIAL signal is shown in Fig. 3.2. Its parameters are described in Table 3.2.

**Table 3.1:** Parameters of the EXPONENTIAL signal.

Parameter	Name	Default value	Units
Initial value	V1	0	volt
Pulsed value	V2	1	volt
Rise delay time	TD1	0	sec
Rise time constant	TC1	1	sec
Fall delay time	TD2	6	sec
Fall time constant	TC2	1	sec

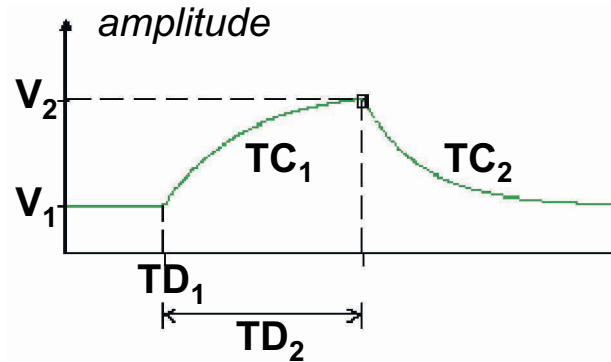
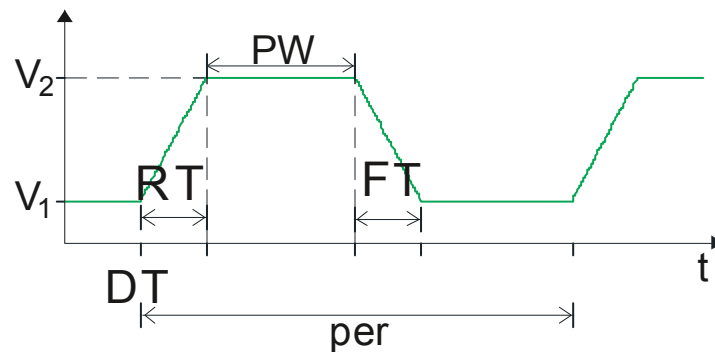

**Figure 3.2:** EXPONENTIAL signal.

The EXPONENTIAL signal has the constant voltage  $V_1$  from  $t = 0$  s up to time  $TD_1$ , where it begins to rise with a time constant  $TC_1$ . It keeps increasing its value during  $TD_2$  s to reach the value  $V_2$  when it begins to decrease in value with a time constant  $TC_2$ .

### 3.2.2 PULSE SIGNAL

The PULSE signal is shown in Fig. 3.3 and has the parameters listed in Table 3.2.



**Figure 3.3:** PULSE signal.

The PULSE signal starts with an initial value  $V_1$  which changes to  $V_2$  at time  $TD$ . The rise time  $RT$  is the time it takes to change its value from  $V_1$  to  $V_2$  where it stays for  $PW$  s and finally it changes its value back to  $V_1$ .  $PER$  is the period of the signal.

**Table 3.2:** Parameters of the PULSE signal.

	Parameters	Default value	Units
V1	Initial value	-1	volt
V2	Pulsed value	1	volt
DT	Delay time	0	sec
RT	Rise time	1	nsec
FT	Fall time	1	nsec
PW	Pulse width	0.5	msec
PER	Period	1	msec

### 3.2.3 PIECEWISE\_LINEAR SIGNAL (PWL)

The PIECEWISE\_LINEAR SIGNAL PWL is shown in Fig. 3.4. The coordinates of each break point are given depending upon the desired form of the signal. They can also be given in a file. There is an option to repeat the data given during the simulation.

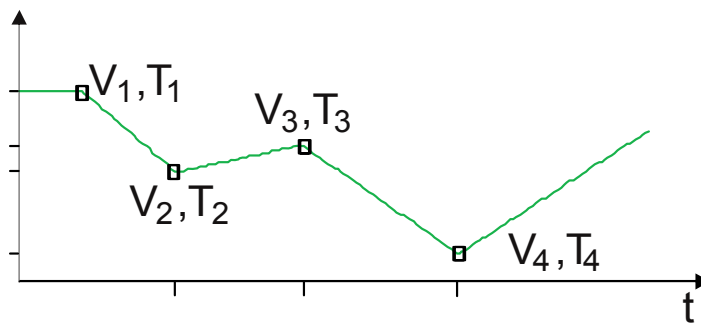
**Figure 3.4:** PIECEWISE signal PWL.**Table 3.3:** Parameters of the PIECEWISE signal.

	Parameter	Nominal value	Units
Tn	Time in a point	None	sec
Vn	voltage in a point	None	volt

### 3.2.4 SINE WAVE AC SIGNAL

A sine wave signal is displayed in Fig. 3.5. Its parameters are listed in Table 3.4.

This signal starts at value VOFF at  $t=0$  seconds for TD seconds and behaves as an exponentially damped sine wave. The sinewave frequency is FREQ and its phase is PHASE. The AC sine wave obeys

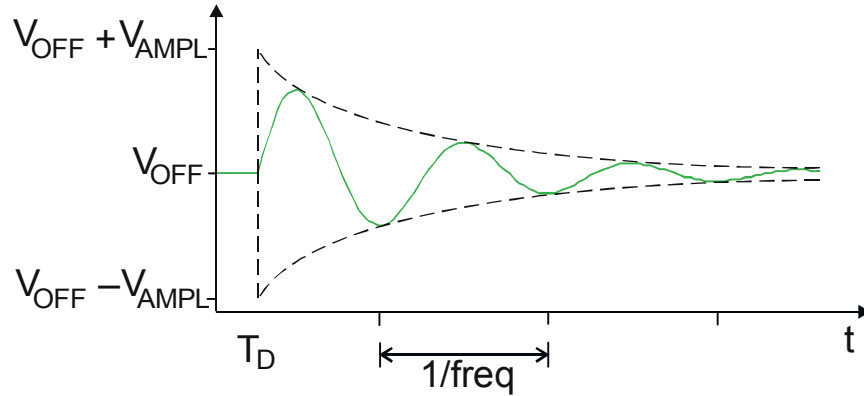

**Figure 3.5:** Waveshape for a SIN signal.

**Table 3.4:** Parameters of the sine wave AC signal.

Parameters	Default value	Units	
VOFF	Signal offset	1	volt/ampere
VAMPL	Signal peak	0	volt/ampere
FREQ	Frequency	1	kHz
TD	Time delay	0	second
DF	Damping factor	0	
PHASE	Phase	0	degrees

the equation

$$VSIN(t) = V_{OFF} + V_{AMPL} \sin[2 * FREQ(t + TD) + PHASE/360^\circ] e^{-(t-TD)/DF}$$

### 3.2.5 FREQUENCY MODULATED SIGNAL FM

The frequency modulated signal FM is shown in Fig. 3.6. This signal obeys the equation (this equation is valid for both voltage or current)

$$I(t) = I_{OFF} + I_{AMPL} \sin[2\pi FCt + MOD \sin(2\pi FMt)]$$

Its parameters are given in Table 3.5.

### 3.2.6 THERMAL NOISE SIGNAL

It is a source used for noise analysis. We have to specify the bandwidth, the temperature, and the equivalent resistance. A typical waveform is shown in Fig. 3.7.

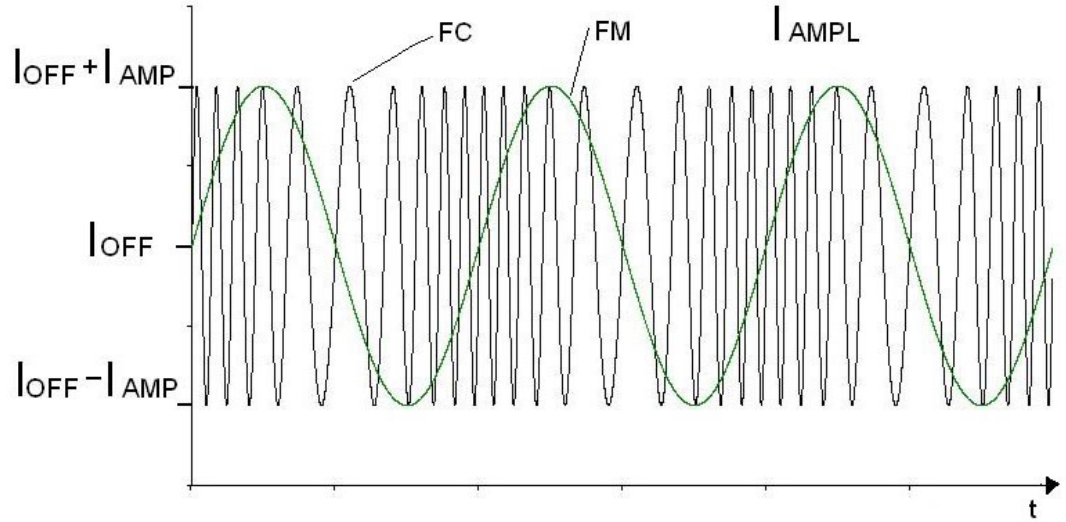

Figure 3.6: Waveform for the frequency modulated FM signal.

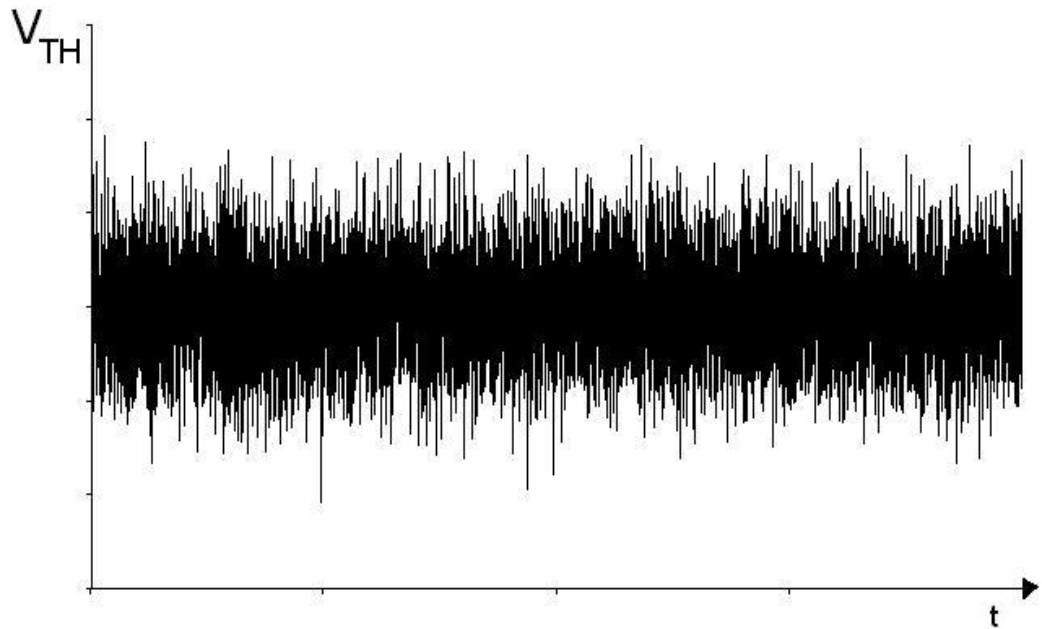

Figure 3.7: Waveform for the thermal noise signal.

**Table 3.5:** Parameters of the frequency modulated signal FM.

	Parameters	Default value	Units
I <sub>OFF</sub>	Offset value	1 A	amperes
I <sub>AMPL</sub>	Amplitude value	0	amperes
FC	Carrier frequency	1	KHz
MOD	Modulation index	5	
FM	Intelligence frequency	100	hertz

**Table 3.6:** Parameters of the modulated signal AM.

	Parameters	Default value	Units
VAMPL	Carrier amplitude	5	volt
FC	Carrier frequency	1	kHz
M	Modulation index	1	None
FM	Intelligence frequency	100	Hertz

### 3.2.7 AMPLITUDE MODULATED SIGNAL AM

The amplitude modulated signal AM is shown in Fig. 3.8. It only exists for voltage sources. The parameters are given in Table 3.6.

The AM source (single-frequency amplitude modulation source) generates an amplitude modulated waveform. It obeys the equation

$$V(t) = V_{AMPL} \sin(2\pi FCt)[1 + M \sin(2\pi FMt)].$$

## 3.3 TIME DOMAIN ANALYSIS – TRANSIENT ANALYSIS

Transient analysis is the name of the analysis in the time domain. This analysis can be performed by choosing Simulate in the Multisim menu, then Analysis and Transient Analysis..., that is,

Simulate → Analyses → Transient Analysis...

Which opens the dialog window of Fig. 3.9. The data we need to enter is

Starting time for simulation      **Start time(TSTART)**

Final time for the simulation      **End time (TSTOP)**

In a transient analysis, Multisim solves numerically a set of differential equations. The time step is adjusted to ensure a successful convergence of the solution. To this purpose, we have the option to give a maximum time step TMAX. Alternatively, we can also define the maximum number of

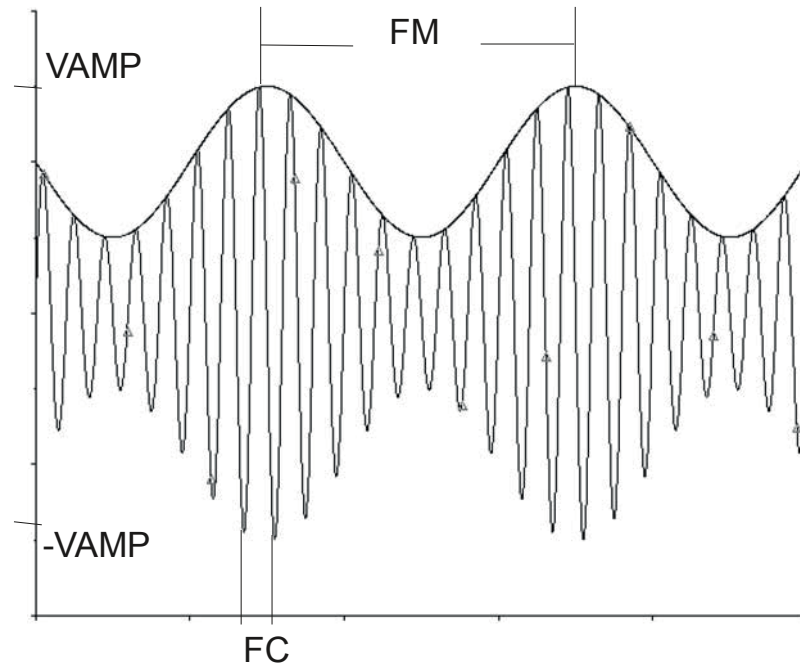

**Figure 3.8:** AM signal.

time points in the simulation. An additional parameter we can give is the initial time step TSTEP. An example will show how a transient analysis is performed.

#### **Example 3.1 RLC Circuit.**

The circuit of Fig. 3.10 is a lowpass elliptic filter. We apply a PULSE signal which changes from 0V to 1V. It has a period of 8 sec and a duty cycle of 5 sec. The rise and fall times are both equal to 1 nsec. We perform a transient analysis from 0–10 sec in the dialog window of Fig. 3.11. We plot the input signal and the voltage across resistor R2. The results are shown in Fig. 3.12. Due to the time constants, we see that the output signal takes almost 5 sec to reach its maximum value.

#### **Example 3.2 Circuit with an initial condition in the capacitor.**

A transient analysis allows the specification of initial conditions in capacitors and inductors. For inductors the initial condition is a current and for capacitors it is a voltage. Initial condition can be given by double clicking on the element. This opens a window where the initial condition desired value is entered. Let us consider the circuit of Fig. 3.13. The dialog window of Fig. 3.14 shows that we are specifying an initial condition of 10V for the capacitor. The parameters for the



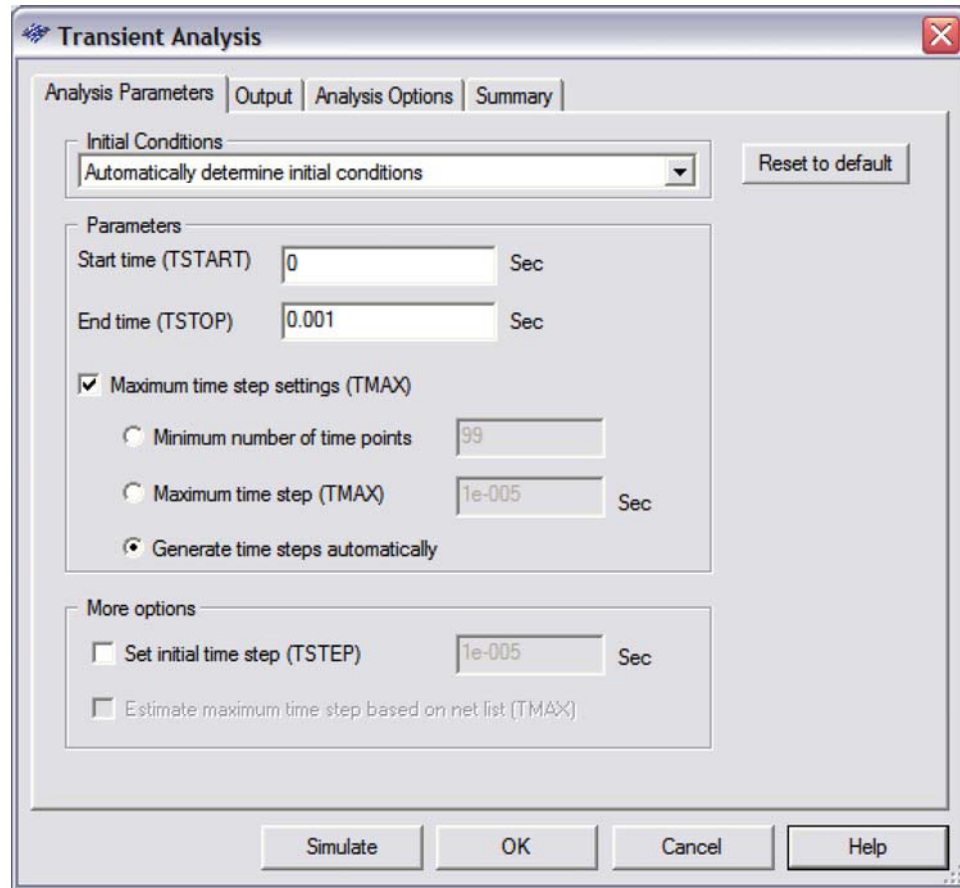

**Figure 3.9:** Dialog window for transient analysis.

transient analysis are given in Fig. 3.15. The plot of Fig. 3.16 shows that the capacitor voltage at  $t = 0$  is 10 V and from there the capacitor discharges slowly with a time constant  $t = RC = 10$  msec.

### 3.3.1 USE OF CURSORS

Often we wish to know the value of the signal displayed at a certain time. To do this we use anyone of the two available. In a plot, cursors are enabled by clicking on the cursor icon in the toolbar of the plot. The cursor icon is shown in Fig. 3.17. When we click on the cursor icon, a small green triangle appears on top of the vertical axis which corresponds to one of the two cursors available. They can be positioned on the desired position along the horizontal axis by clicking on it and moving it with the mouse. The same procedure applies to cursor number 2.

52 3. TIME DOMAIN ANALYSIS – TRANSIENT ANALYSIS

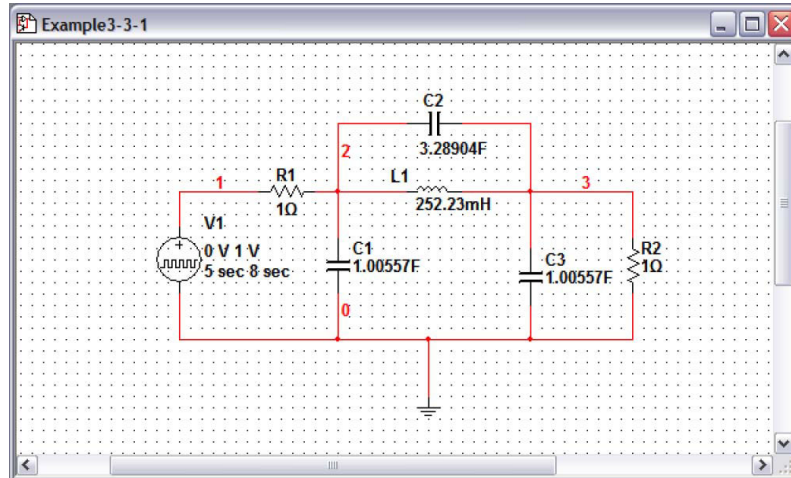

Figure 3.10: RLC circuit for transient analysis.

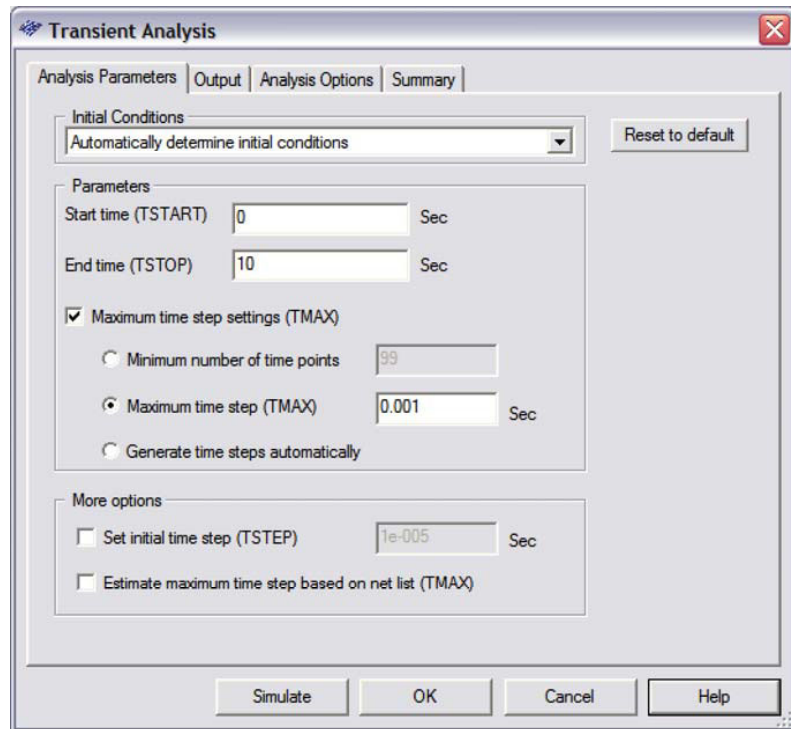

Figure 3.11: Dialog window for transient analysis.

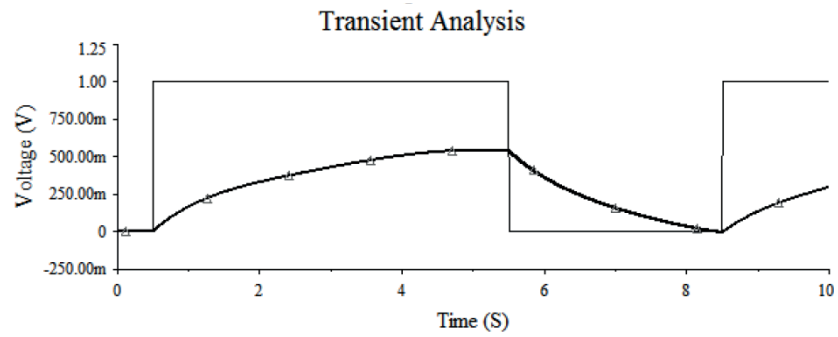

Figure 3.12: Plots of input and output signals for the RLC circuit.

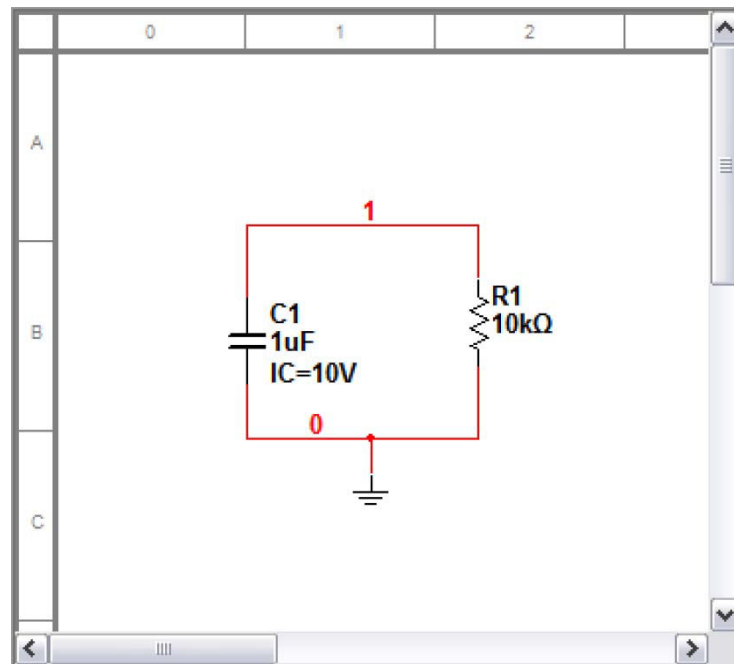
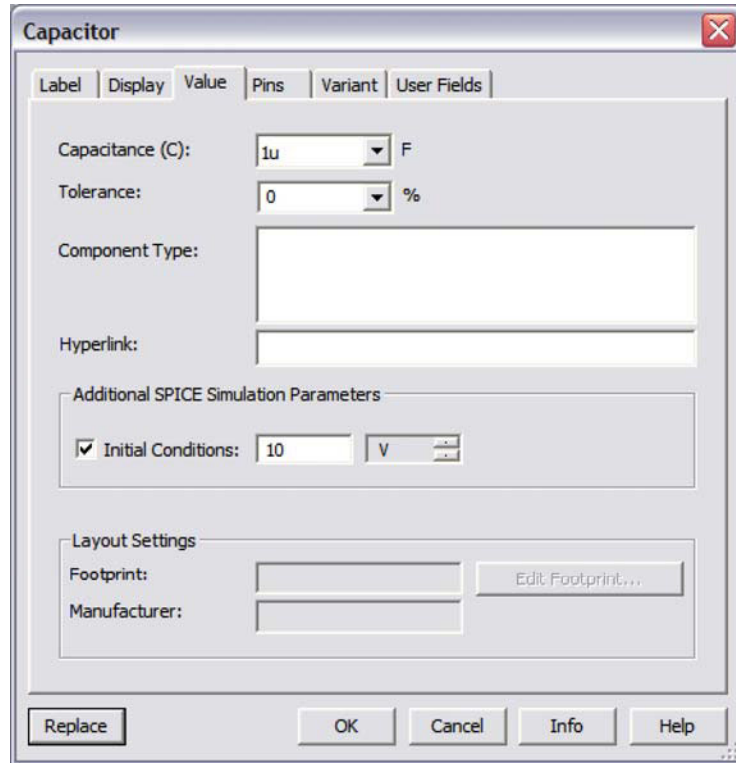

Figure 3.13: Circuit with initial conditions.



**Figure 3.14:** Specifying initial conditions for the capacitor.

As an example we use the plot available in Fig. 3.15. Once the cursor icon is clicked we can move the cursors to the desired position, as shown in Fig. 3.18. We also see that a small window appears showing the coordinates of the point where each of the cursor is positioned. Also available are the differential, the inverse of the differential, the minimum and maximum values for the coordinates, and the offset values.

Cursors are disabled by clicking on the cursor icon again.

### 3.4 THE OSCILLOSCOPE AND THE DISTORTION ANALYZER

Multisim has available a set of virtual instruments that behave in the same way as the real ones in the laboratory. They are available from the Instruments toolbar of Fig. 3.19. Here we discuss two of them: the Oscilloscope and the Distortion Analyzer.

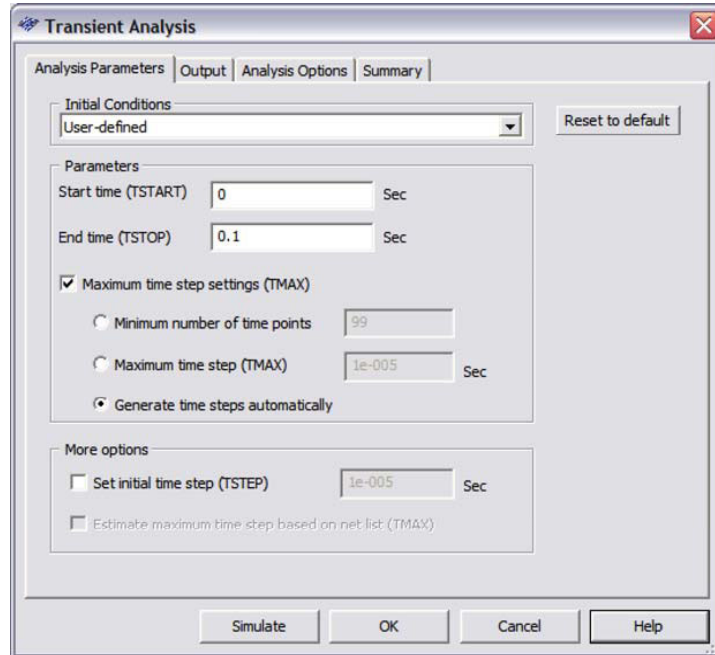

Figure 3.15: Dialog window to specify the transient analysis.

## Circuit1 Transient Analysis

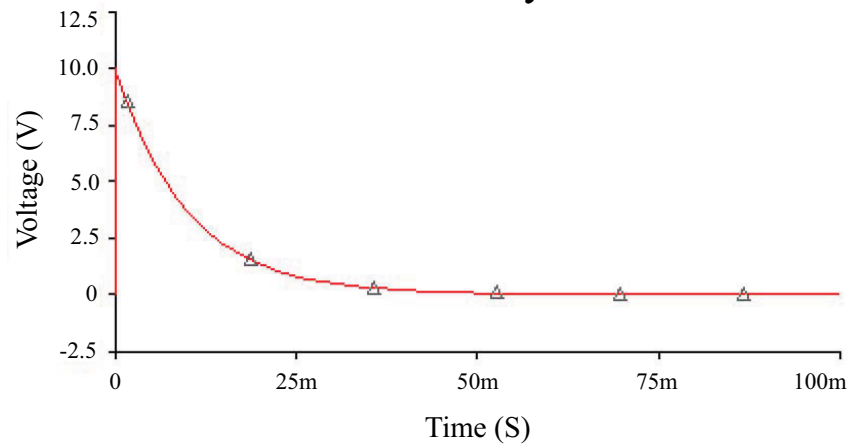
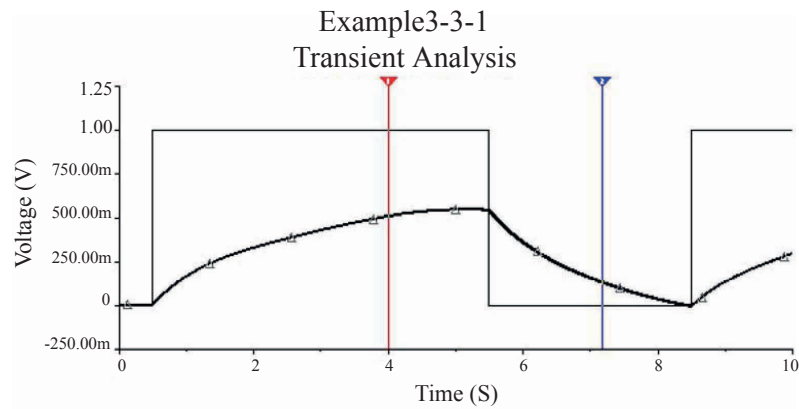

Figure 3.16: Capacitor voltage.



Figure 3.17: Icon to enable cursors.



(a)

Transient Analysis		
	V (3)	V (1)
x1	4.0041	4.0041
y1	506.2319m	1.0000
x2	7.1748	7.1748
y2	130.2589m	0.0000
dx	3.1707	3.1707
dy	-375.9730m	-1.0000
1/dx	315.3846m	315.3846m
1/dy	-2.6598	-1.0000
min x	0.0000	0.0000
max x	10.0000	10.0000
min y	-6.8927m	0.0000
max y	542.6220m	1.0000
offset x	0.0000	0.0000
offset y	0.0000	0.0000

(b)

Figure 3.18: (a) Plot with cursors enabled, (b) values of signals at cursors.



**Figure 3.19:** Instruments toolbar.

### 3.4.1 THE OSCILLOSCOPE

The oscilloscope is a very useful and important instrument in the laboratory. Two channel and a four channel oscilloscopes are available as seen in Fig. 3.20. The operation of both oscilloscopes is very similar. Their operation is illustrated with the circuit of Example 3.1.

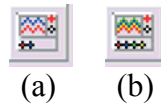

**Figure 3.20:** (a) Two-channel and (b) four-channel oscilloscopes.

#### Example 3.3 Use of the oscilloscope.

An oscilloscope has been added to the schematic of the circuit in Example 3.3 and the channel A connected to the output of the circuit (see Fig. 3.21). When we double click on the oscilloscope symbol we open the window of Fig. 3.22 which resembles a two channel oscilloscope.

Since the simulation runs up to 10 sec, we change the base time of the oscilloscope to 1 sec/Div and the Channel A input to AC and 0.5 V/Div and then click on the Run icon or press F5. The output is shown in Fig. 3.23. There we see the output waveform. We can see that there are cursors at both ends of the plot. These cursors can be used to show signal values at different time points in the plot. The cursors can be positioned with the arrows in the top left corner of the instrument panel. The values of the signal at each cursor position as well as the difference between those values is displayed next to the arrows (see Fig. 3.24).

Note that the oscilloscope only displays when the Run button is clicked on. The analysis that runs when this is done is a Transient Analysis with the conditions established in the dialog window that is displayed when we choose Simulate→Interactive Simulation Settings. The window is shown in Fig. 3.25. There we select the time limits for our circuit simulation, which in this example are End Time (TSTOP) = 10 sec with a TMAX of 0.1 sec. This is also the case for the Voltmeter, Ammeter, and Multimeter introduced in Chapter 2.

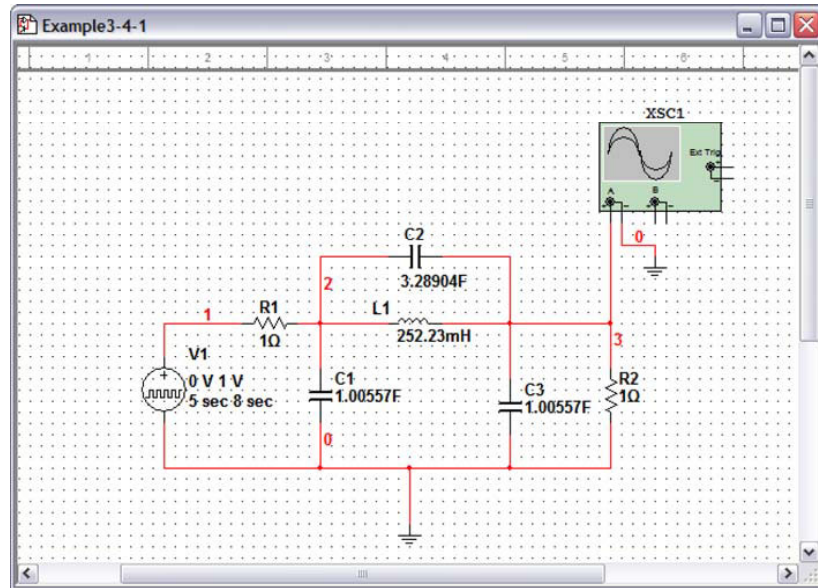

Figure 3.21: Circuit with an oscilloscope connected to the output.

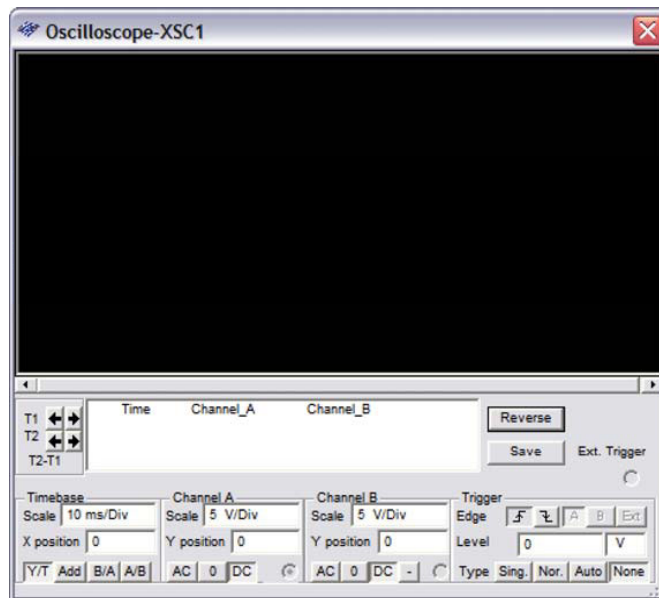

Figure 3.22: Oscilloscope window.



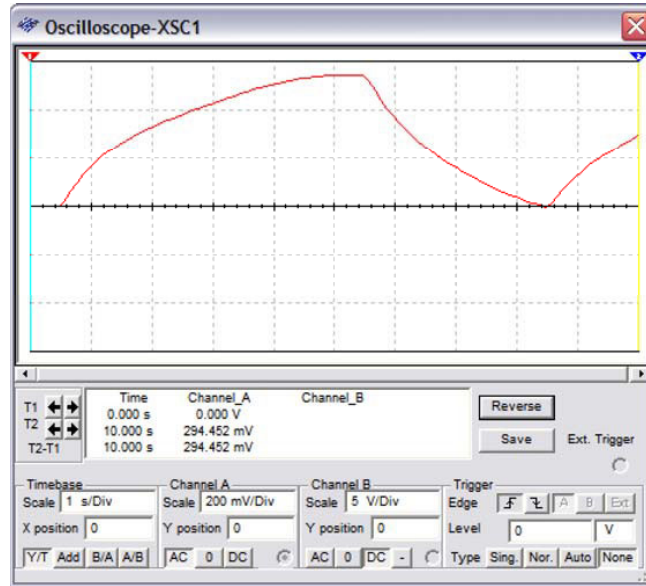

Figure 3.23: Oscilloscope window showing the output waveform.

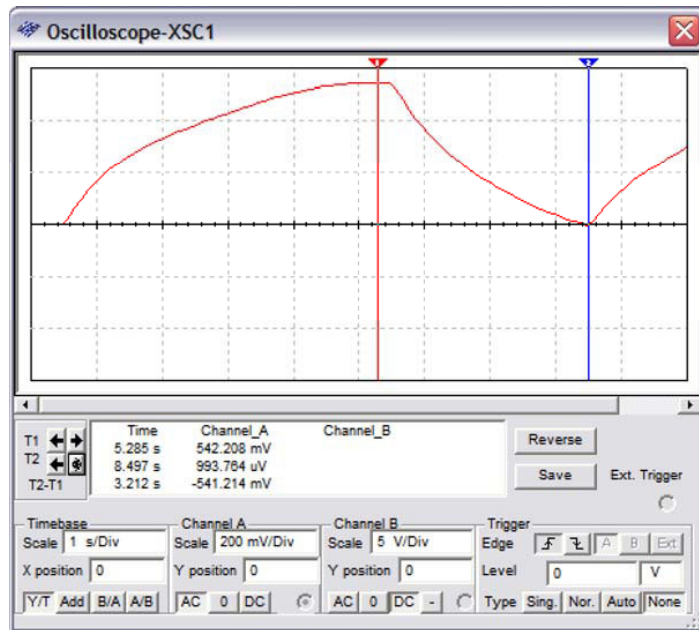
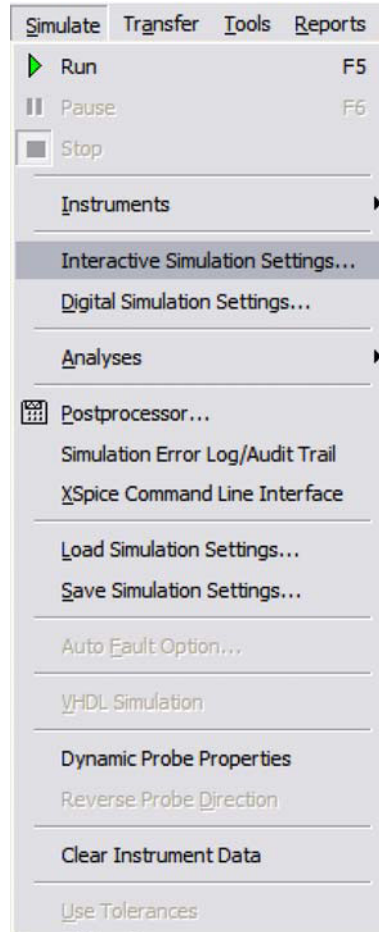

Figure 3.24: Oscilloscope with the cursors' position displayed.



**Figure 3.25:** Pull-down menu to specify the parameters of the Interactive Simulation Settings analysis.

### 3.4.2 THE DISTORTION ANALYZER

The Distortion Analyzer is selected by clicking on it on the Instruments toolbar, placing it alongside the circuit and wiring it to the desired node in the circuit. The Distortion Analyzer window is shown in Fig. 3.26 (a). Here we give the Fundamental Frequency for the distortion measurement. The Set button allows the specification of the number of harmonics used in the Total Harmonic Distortion (THD) measurement (see Fig. 3.26 (b)), the default value is 10.

#### Example 3.4 Distortion analyzer measurements

We use the circuit of Fig. 3.27. It is an inverting amplifier with a gain of -10 using an LM324J

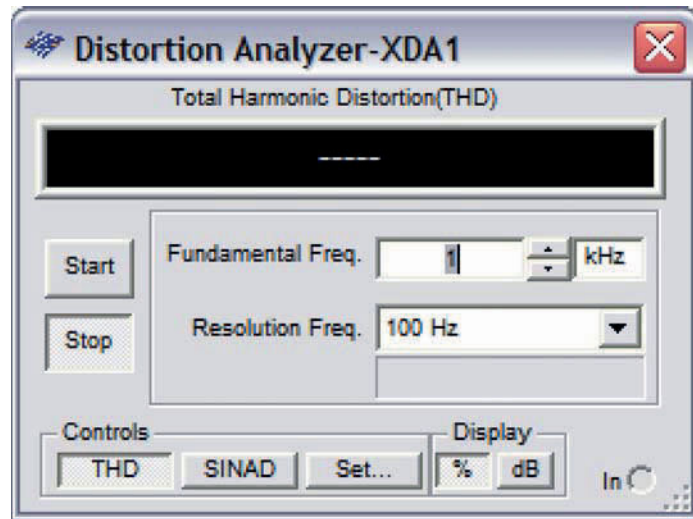

(a)

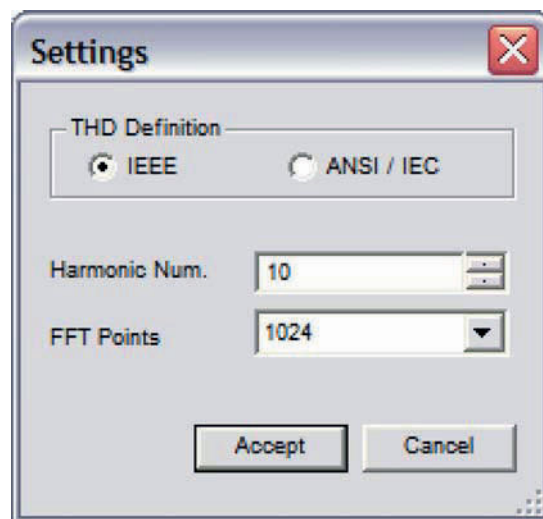

(b)

**Figure 3.26:** Distortion analyzer: (a) Main window, (b) Settings window.

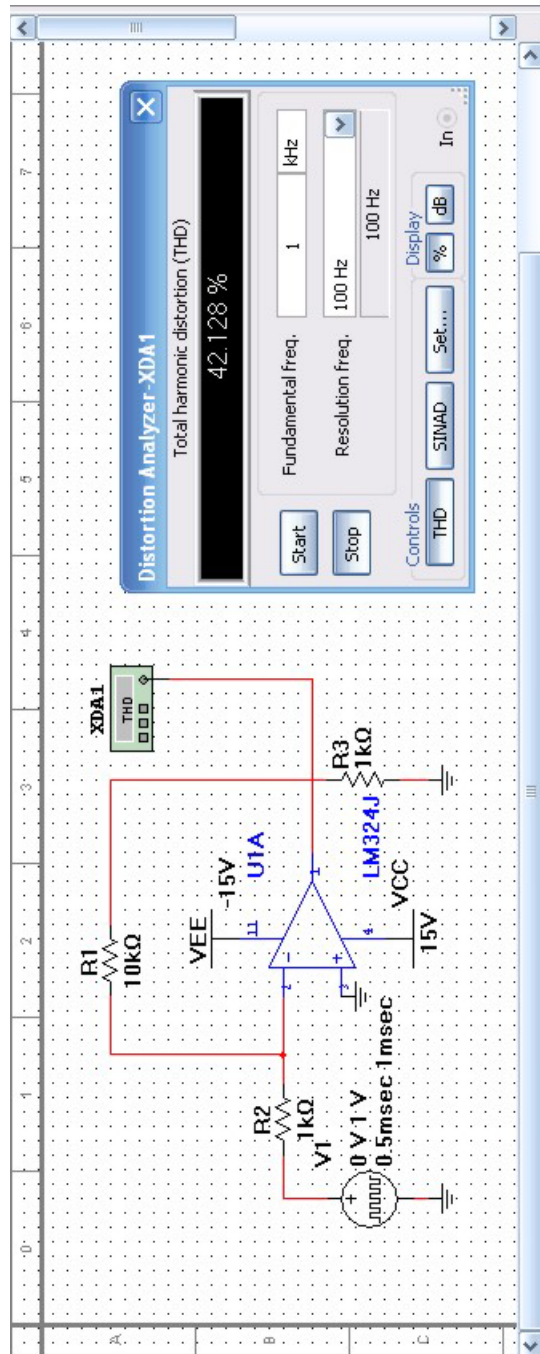

Figure 3.27: Inverting amplifier to measure THD.

operational amplifier. In the Simulate→Interactive Simulation Settings...we set the TSTOP to 0.1 sec and run the simulation with the Run button or F5. The THD is shown in the Distortion Analyzer window, which is 42.86%. The THD is very large because the input signal is a square signal rich in harmonic content.

## 3.5 FOURIER ANALYSIS

Multisim has the capability to perform a Fourier analysis to the signals in the circuit being simulated. Thus, we can obtain a harmonic decomposition for either a voltage or current in the circuit. This type of analysis receives the name of its creator Jean Fourier (1768-1830), who developed the mathematical basis to express any periodic function as a sum of sine waves.

To perform a Fourier analysis we use from the menu Simulate→Analyses→Fourier Analysis. This action opens the dialog window of Fig. 3.28.

In this window we specify the fundamental frequency for the Fourier analysis and the number of harmonics we wish to see as well as the final time TSTOP for the analysis. We can also specify the way we wish to see the results (either Display phase, Display as a bar graph, or Normalize graphs). We use the simple circuits of Fig. 3.29 to show a Fourier analysis. Let us consider the circuit in Fig. 3.29 (a) which has a sine wave as input signal. The input data is given in Fig. 3.30. Since the frequency of the sine source is 1 KHz, we choose this frequency as the fundamental frequency in the Fourier analysis. Also, we calculate the first 20 harmonics. Finally, we perform the transient analysis for 2 msec.

After running the Fourier analysis we see the Grapher window where there is a spreadsheet (see Fig. 3.31) showing the data of the analysis. Here, we see the DC component value, the number of harmonics calculated, the THD (Total Harmonic Distortion), the magnitude and phase of each of the harmonics, and finally the normalized magnitude and phase of each of the harmonics. THD is calculated with the harmonics calculated in the analysis, thus, the more harmonics we choose to calculate, the more accurate is the result of THD. Fig. 3.32 is a plot of the magnitude of the harmonics. Since the signal analyzed is a sine wave we only see a single component, a very small THD, and the harmonic components are negligible.

Now, let us consider the circuit in Fig. 3.29 (b). The input signal is a Pulse signal. We repeat in Fig. 3.33 the same Fourier analysis as before but we choose as the output variable V(2). The Grapher window shows the spreadsheet with the output data. Since we have a square signal at the input we now have a very large THD. The plot of Fig. 3.34 presents the magnitude of the harmonic components.

From this information we can see that the DC component is 0.5. The first few harmonic components and the corresponding total harmonic distortion are also included in Fig. 3.33.

### Example 3.5 Half wave rectifier.

To the circuit of Fig. 3.35 we apply a 60 Hz sine wave (the period of this signal is  $T = 1/60 =$

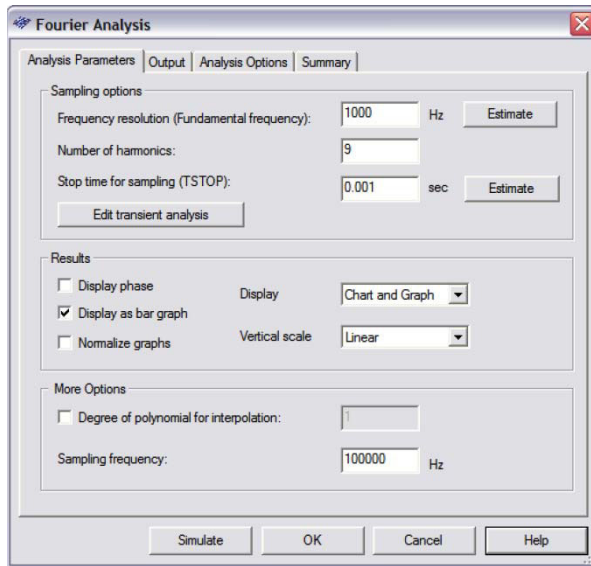

Figure 3.28: Dialog window for a Fourier analysis.

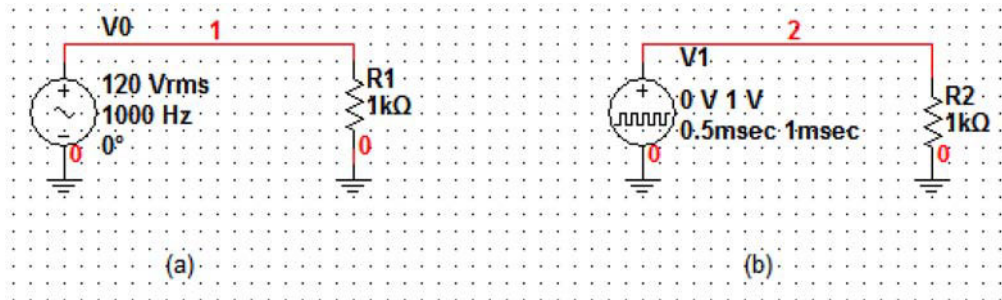

Figure 3.29: Circuits for Fourier analysis.

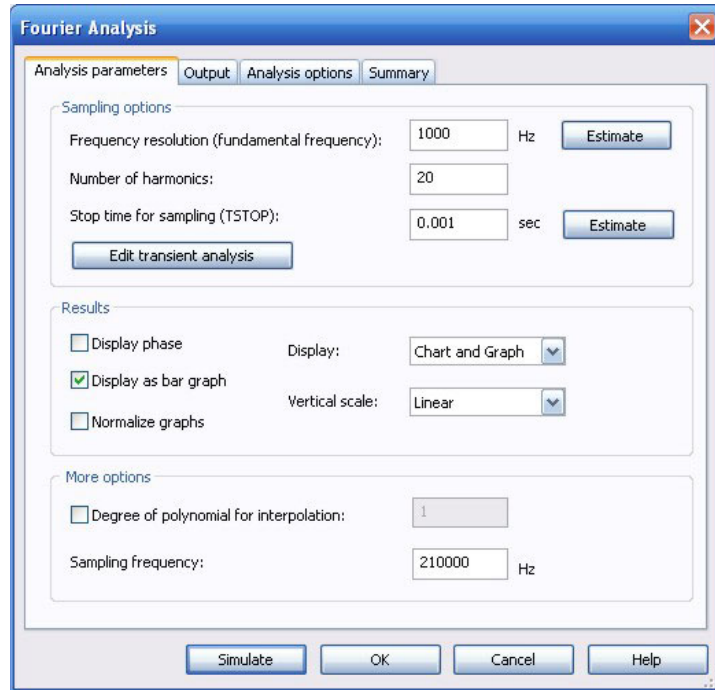
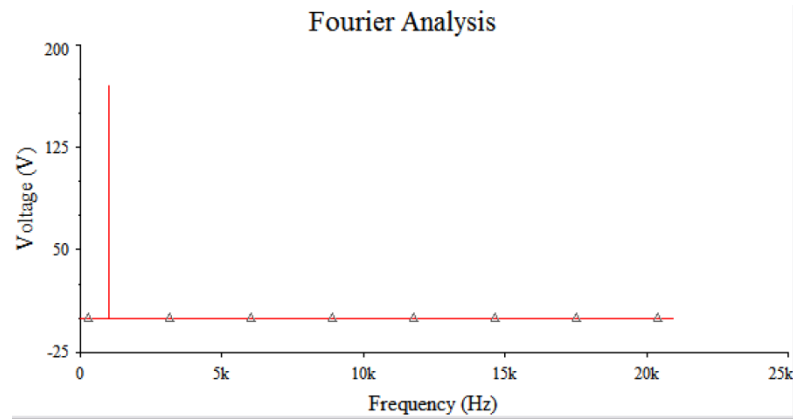

Figure 3.30: Input data for Fourier analysis.

1	Fourier analysis for V(1):					
2	DC component:	4.93674e-009				
3	No. Harmonics:	20				
4	THD:	1.01639e-005 %				
5	Gridsize:	512				
6	Interpolation Degree:	1				
7						
8	Harmonic	Frequency	Magnitude	Phase	Nom. Mag	Nom. Phase
9	1	1000	169.693	1.12321e-006	1	0
10	2	2000	7.37976e-008	-19.932	4.34888e-010	-19.932
11	3	3000	2.93675e-006	46.2565	1.73062e-008	46.2565
12	4	4000	1.66467e-008	-96.615	9.80985e-011	-96.615
13	5	5000	2.49476e-006	76.3351	1.47016e-008	76.3351

Figure 3.31: Spreadsheet with data from Fourier analysis.



**Figure 3.32:** Plot of the magnitude of harmonic components.

0.01667 sec). Fig. 3.36 is the dialog window for the specifications of the Fourier analysis. Fig. 3.37 shows the resulting input and output waveforms for a transient analysis. Figs. 3.38 and 3.39 show the spreadsheet with the output data and the plot of the harmonic components magnitude. From this data we see that the THD is 65.852%.

### 3.6 ADDITIONAL EXAMPLES

In this section we present some examples using the concepts and analyses covered in this chapter.

#### Example 3.6 Passband active filter.

The circuit of Fig. 3.40 is an active filter with an operational amplifier LM324. The input is a PULSE signal with a period of 4 msec and a 50% duty cycle. Thus, it has a frequency of 250 Hz, and the pulse width is 2 msec. We make a transient analysis from 0 to 10 msec, as seen in the dialog window of Fig. 3.41. The input and output waveforms are shown in Fig. 3.42. We see that even though the input signal is a square wave with a great deal of harmonic components, the output resembles a sine wave. This is due to the fact that the circuit is filtering a large number of harmonics.

We then perform a Fourier analysis. Since the period of the input signal is 4 msec, the frequency is 250 Hz. We request 10 harmonic components. We choose as the output variable the voltage V(3). For the TSTOP time we press the Estimate button. The dialog window is that of Fig. 3.43. The results are presented in Fig. 3.44. In the spreadsheet we see that the output signal has a THD of 44.2273%.



Fourier analysis a

1	Fourier analysis for V(2):					
2	DC component:	0.5				
3	No. Harmonics:	20				
4	THD:	45.6981 %				
5	Grid size:	512				
6	Interpolation Degree:	1				
7						
8	Harmonic	Frequency	Magnitude	Phase	Norm. Mag	Norm. Phase
9	1	1000	0.636624	-0.35156	1	0
10	2	2000	6.10491e-016	-82.001	9.58951e-016	-81.649
11	3	3000	0.212219	-1.0547	0.33335	-0.70312
12	4	4000	5.65225e-016	-84.821	8.87848e-016	-84.469
13	5	5000	0.127344	-1.7578	0.20003	-1.4062
14	6	6000	5.67115e-016	-92.904	8.90817e-016	-92.552

Figure 3.33: Spreadsheet with output data when the input is a square signal.

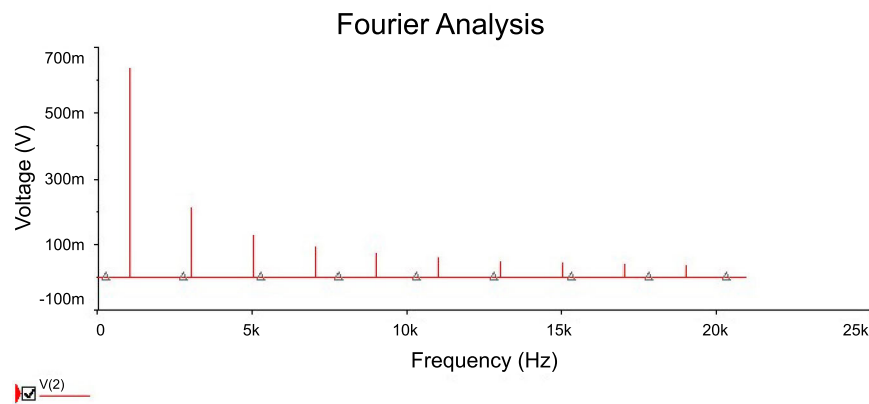

Figure 3.34: Plot of the harmonic components for the square signal.

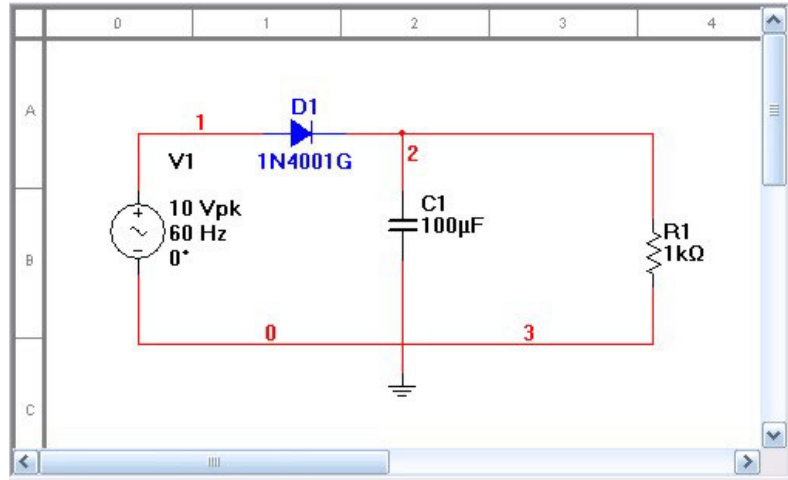

Figure 3.35: Half wave rectifier circuit.

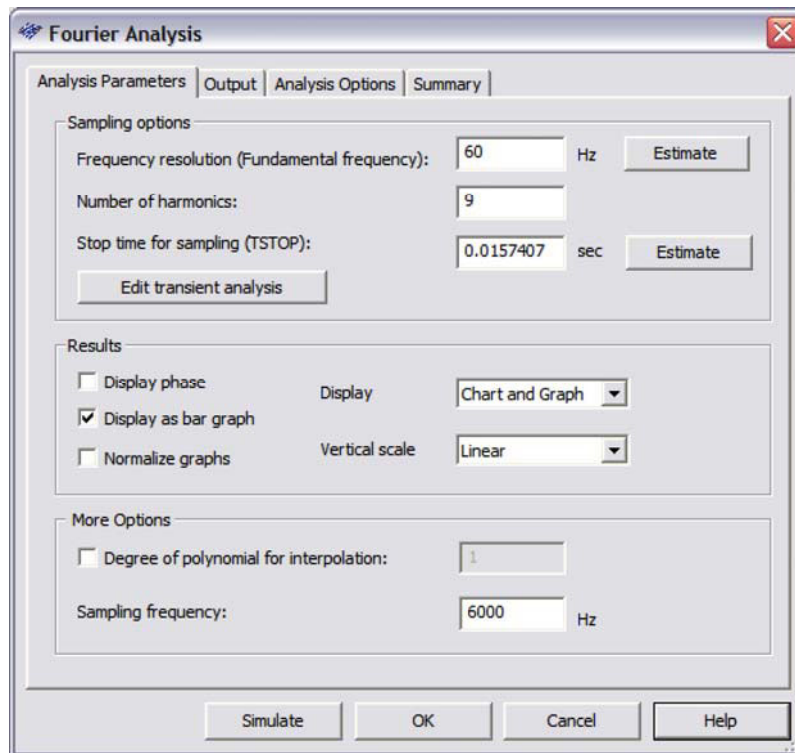

Figure 3.36: Fourier analysis specifications.

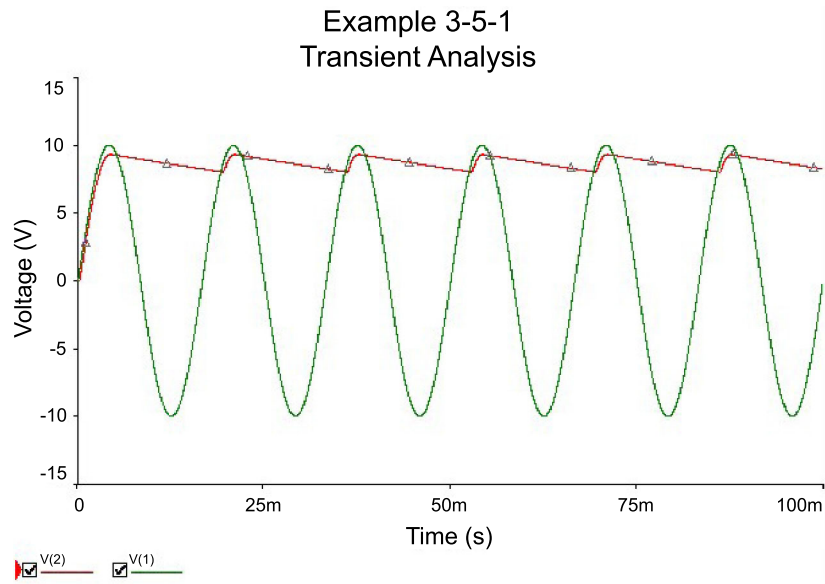

Figure 3.37: Input and output transient analysis waveforms for the half-wave rectifier.

**Example 3-5-1**

1	Fourier analysis for V(2):		
2	DC component:	8.68506	
3	No. Harmonics:	5	
4	THD:	63.2821 %	
5	Grid size:	128	
6	Interpolation Degree:	1	
7			
8	Harmonic	Frequency	Magnitude
9	1	60	0.455958
10	2	120	0.221208
11	3	180	0.140166
12	4	240	0.0978717
13	5	300	0.0713933
14			
			Phase
			88.5596
			174.952
			-97.917
			-10.292
			77.9138

Figure 3.38: Spreadsheet output data for Fourier analysis.

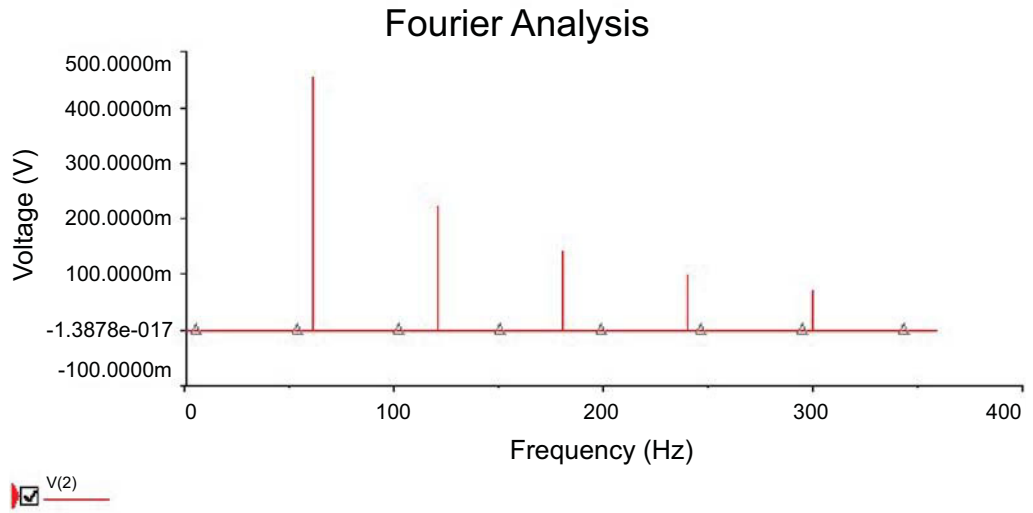

Figure 3.39: Magnitude of the harmonic components.

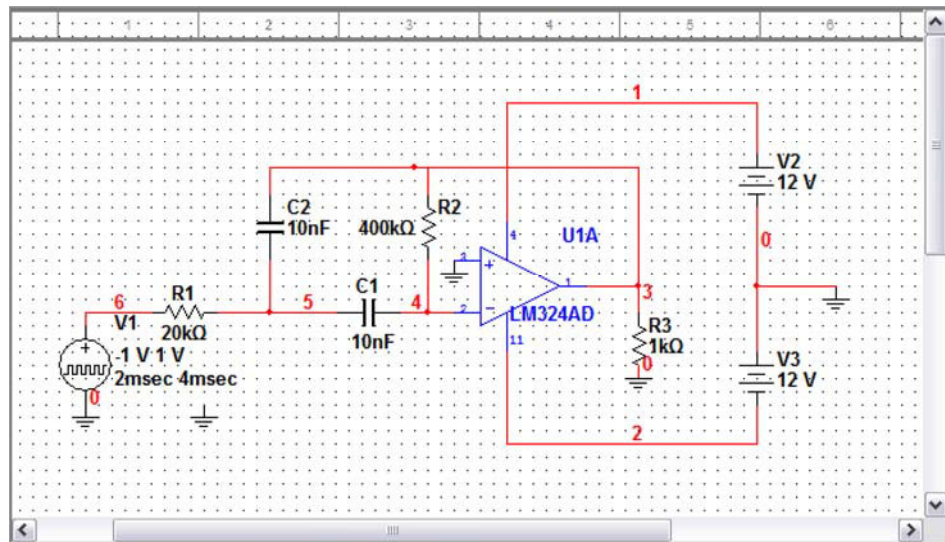
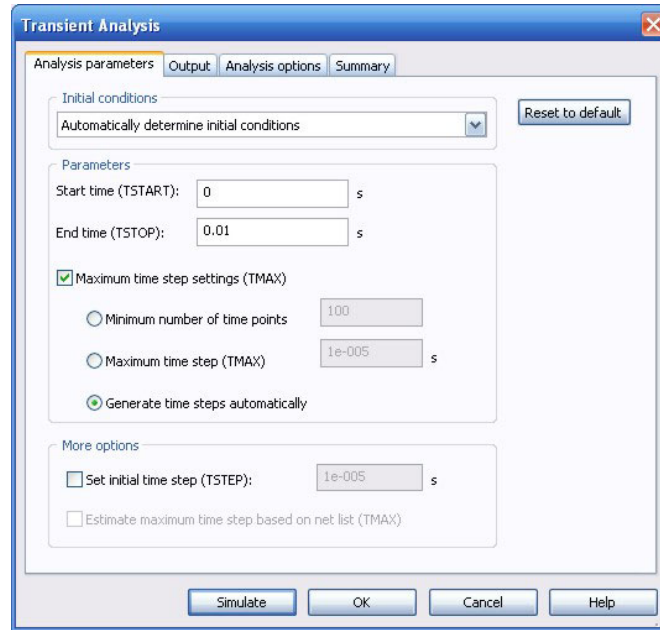

Figure 3.40: RC-active filter.



**Figure 3.41:** Dialog window for the transient analysis.

### Example 3.7 Circuit with initial conditions.

The circuit of Fig. 3.45 is composed of an independent current source with a PULSE waveform, an inductor, a capacitor, and two resistors. The inductor and the capacitor have initial conditions. Figs. 3.46 show the parameters of the PULSE signal. We add the delay to observe the effect of the initial conditions on the response. The initial conditions are added by double clicking on the reactive elements and selecting the Initial conditions square and entering the initial condition for the current in the inductor and the voltage in the capacitor, as shown in Fig. 3.47.

We perform a transient analysis and measure the independent input current and the current through the inductor. To measure the currents we add dummy voltage sources in series with the inductor and the current source as shown in Fig. 3.48. The positive terminal in the dummy voltage source is connected to the current source because the current in a voltage source enters the positive terminal. Since the period of the current source is 20 sec, the transient analysis runs for 40 sec as shown in Fig. 3.49. We have selected the User-defined option in the Initial Conditions pull down menu in Fig. 3.49 so the circuit uses the initial conditions for the analysis. After running the analysis we obtain the plots of Fig. 3.50. To compare the results of the analysis we run the analysis using only the initial condition at the capacitor and with no initial conditions. The results are shown in Fig. 3.51.

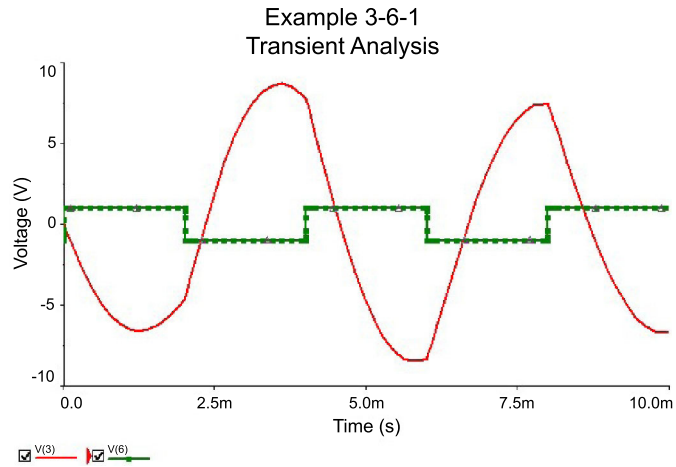

Figure 3.42: Input and output signals for the active filter.

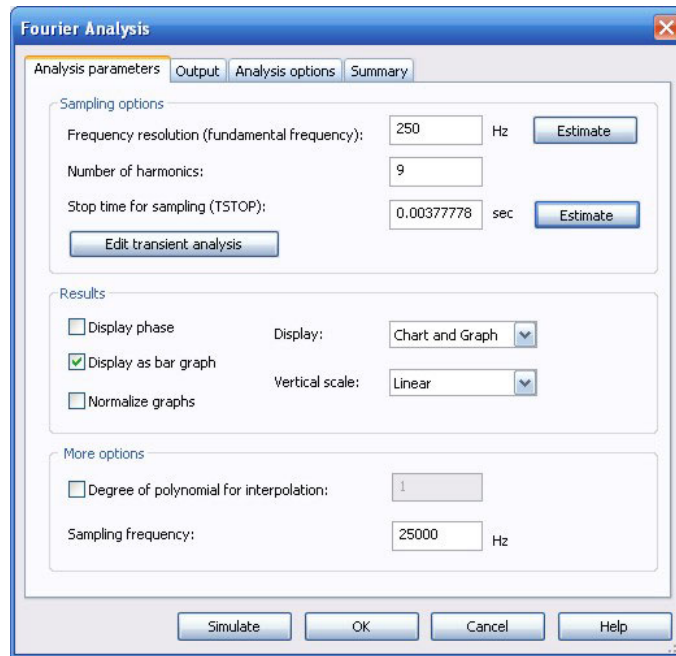

Figure 3.43: Dialog window for the Fourier analysis.

Example 3-6-1

1	Fourier analysis for V(3):		
2	DC component:	-0.63775	
3	No. Harmonics:	9	
4	THD:	7.84862 %	
5	Grid size:	256	
6	Interpolation Degree:	1	
7			
8	Harmonic	Frequency	Magnitude
9	1	250	7.96985
10	2	500	0.186741
11	3	750	0.549977
12	4	1000	0.0484941
13	5	1250	0.19307

Fourier Analysis

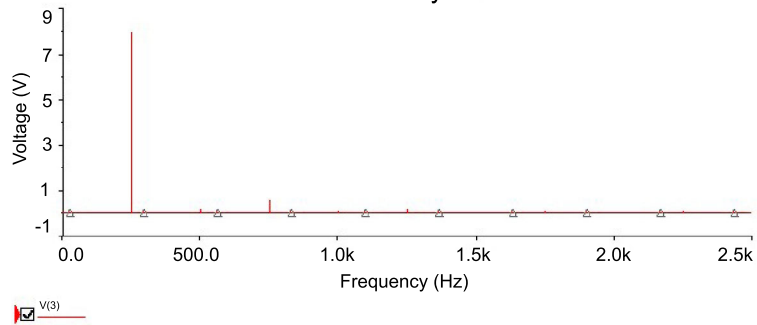

Figure 3.44: Data and plot for the Fourier analysis.

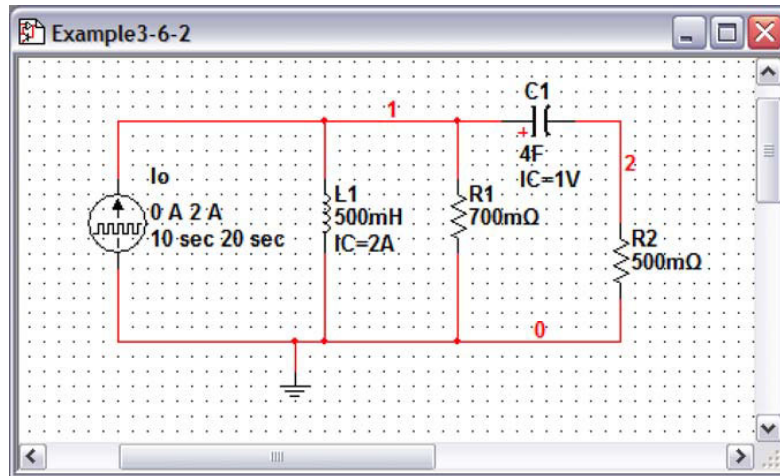
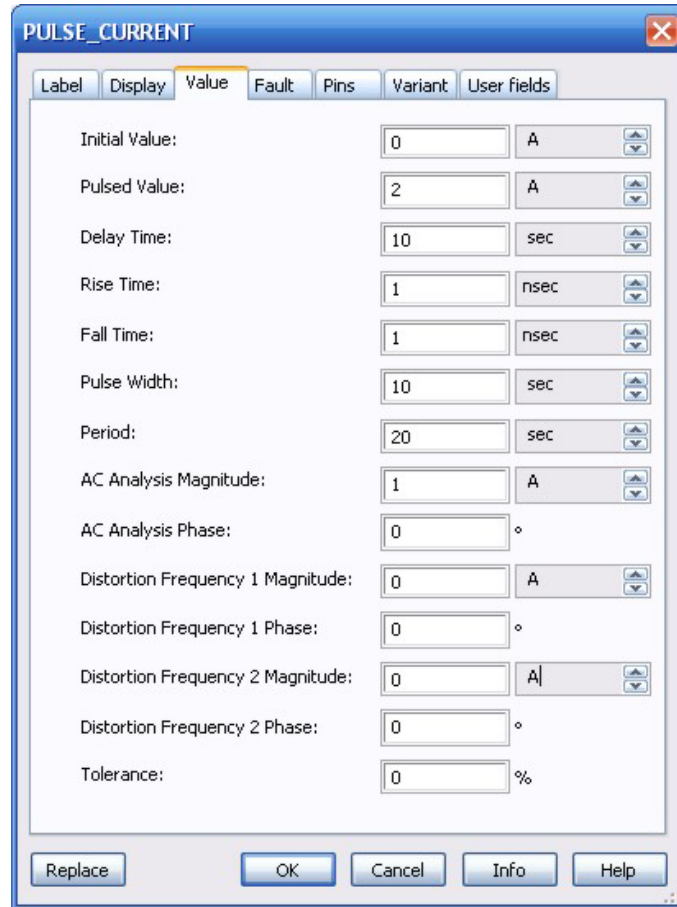

Figure 3.45: RLC circuit with initial conditions in the inductor and capacitor.



**Figure 3.46:** Parameters of the independent current source.

**Example 3.8 Comparator circuit.**

Fig. 3.52 is an inverter comparator. Its function is to sense the input voltage and to give a negative fixed output voltage if the input signal is positive and a positive fixed output voltage if the input voltage is negative. We use the LM324 operational amplifier available in the op-amp set. The circuit in Multisim is shown in Fig. 3.53. The input signal is a sine wave with a 6 volts amplitude and a frequency of 100 Hz.

The transient analysis goes from 0–10 msec as shown in the dialog window in Fig. 3.54. Plots of the input and output signal are shown in Fig. 3.55.



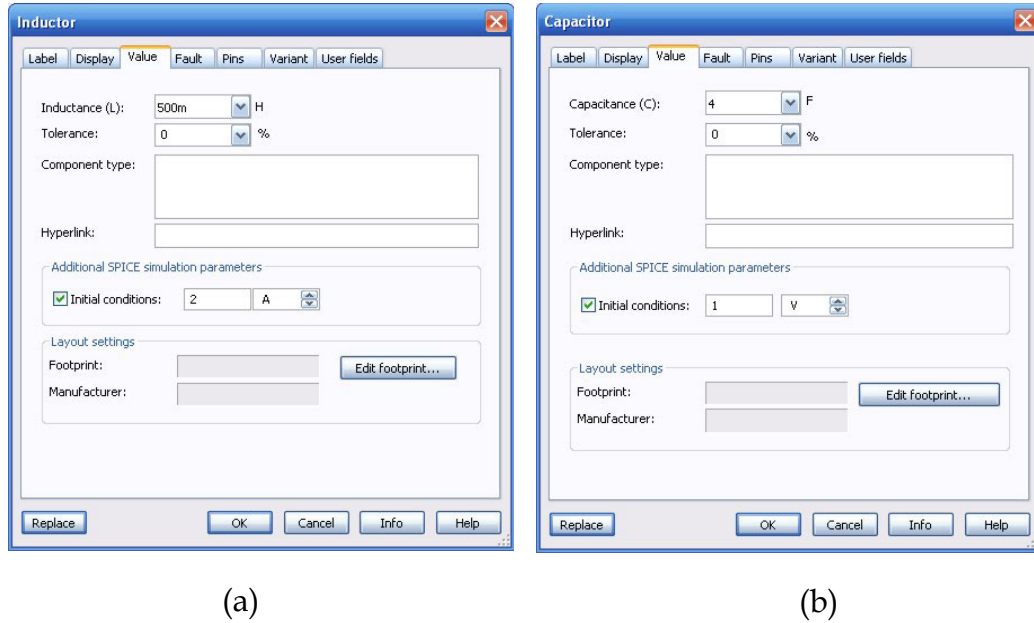

Figure 3.47: Dialog window to enter the initial conditions in a) inductor, b) capacitor.

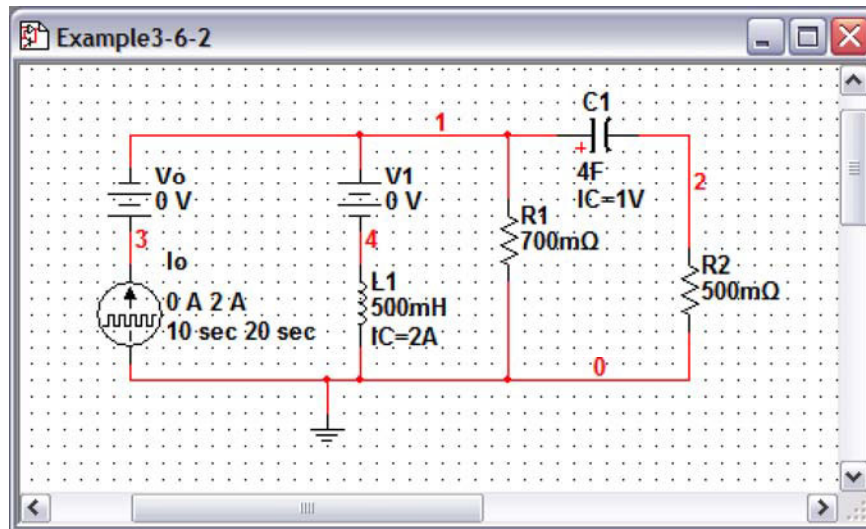

Figure 3.48: Circuit with dummy voltage sources to measure currents.

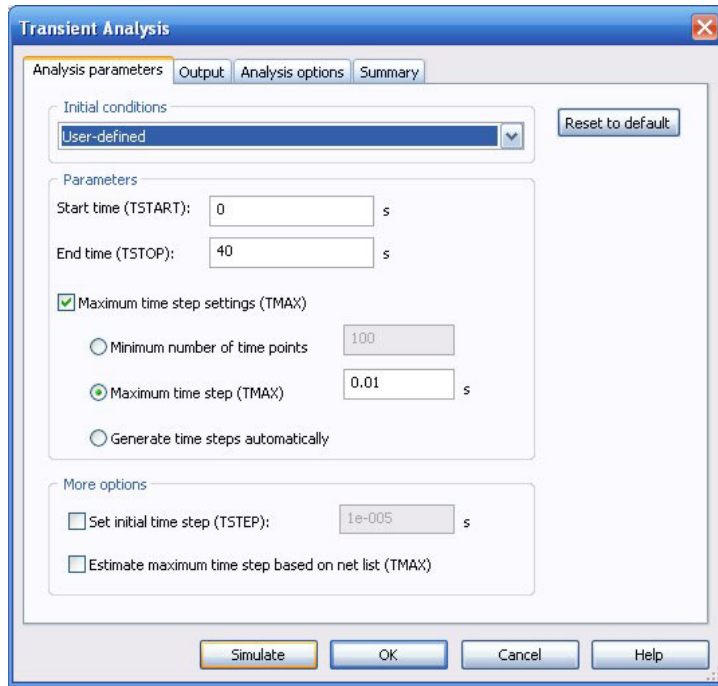

Figure 3.49: Dialog window for the transient analysis with the User-defined initial conditions selected.

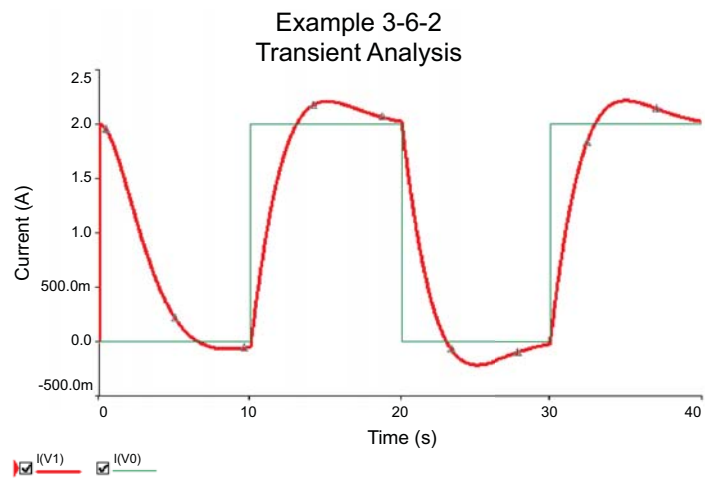
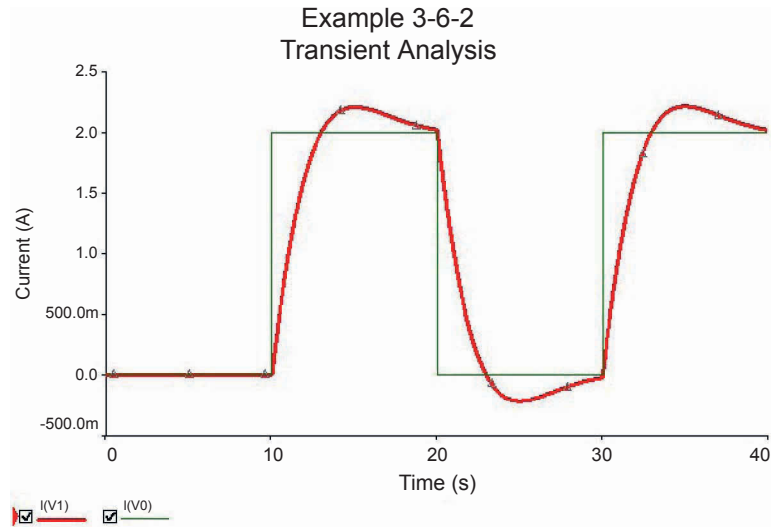
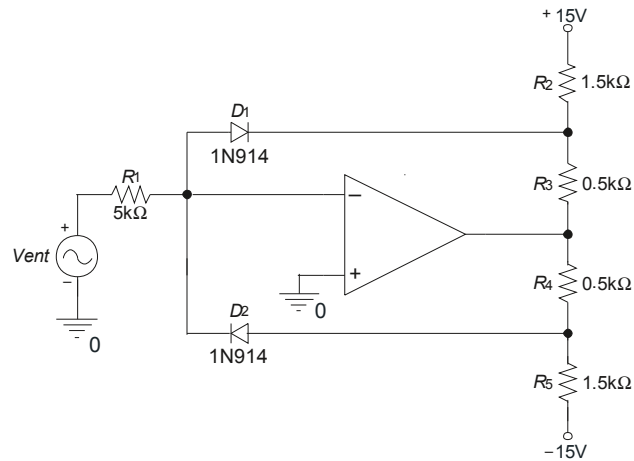

Figure 3.50: Waveforms for the transient analysis using initial conditions.



**Figure 3.51:** Waveforms for the transient analysis of the RLC circuit with no initial conditions.



**Figure 3.52:** Comparator circuit.

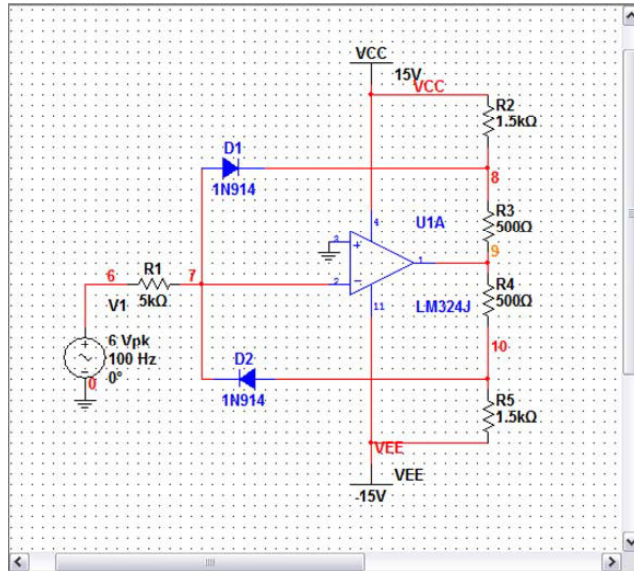

Figure 3.53: Comparator circuit in Multisim.

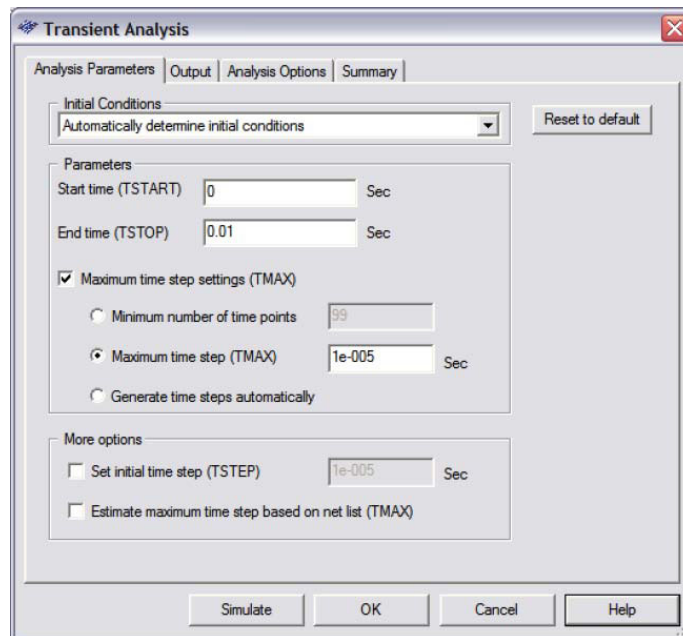

Figure 3.54: Transient analysis specifications.

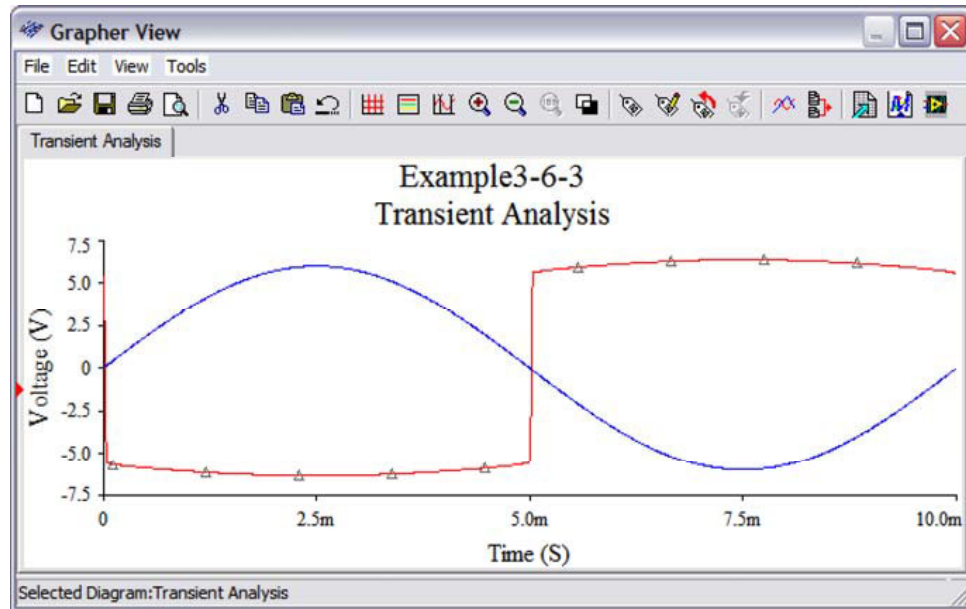

Figure 3.55: Input and output waveforms for the comparator circuit.

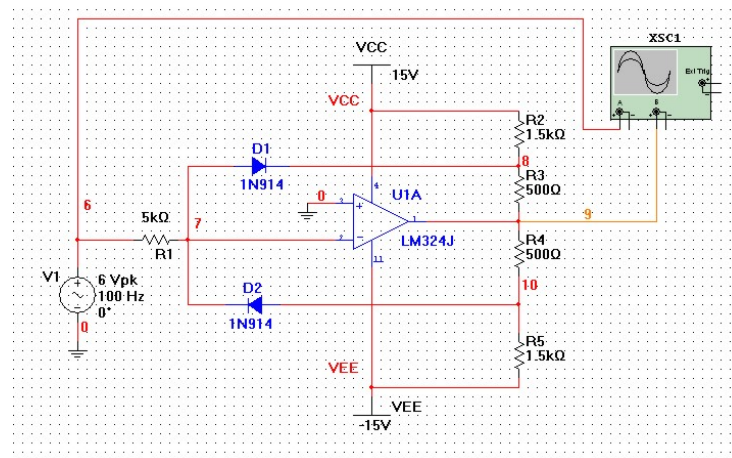

Figure 3.56: Comparator circuit with an oscilloscope added.

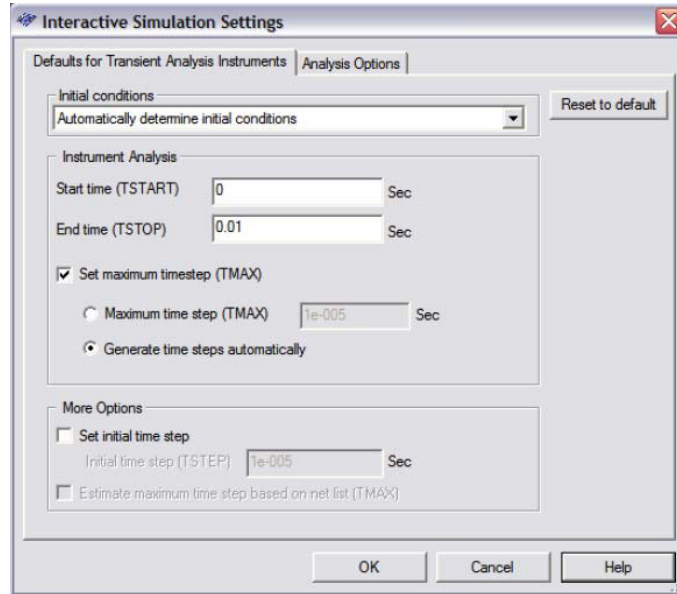

Figure 3.57: Specifications for the Interactive Simulations Settings.

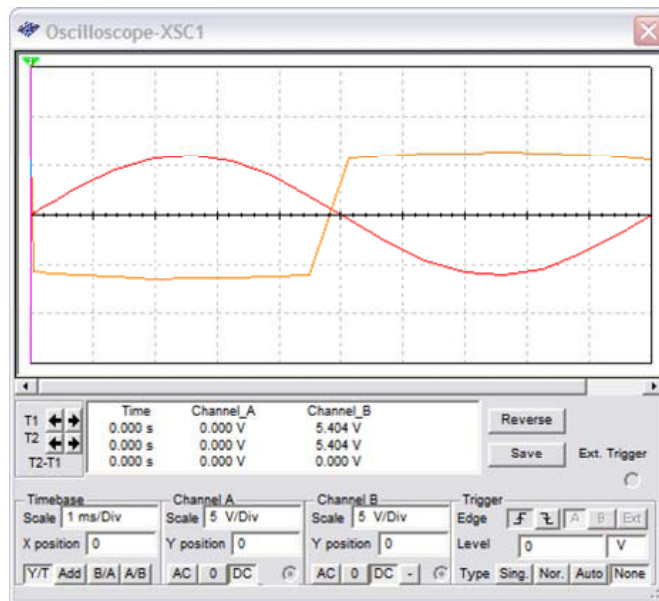
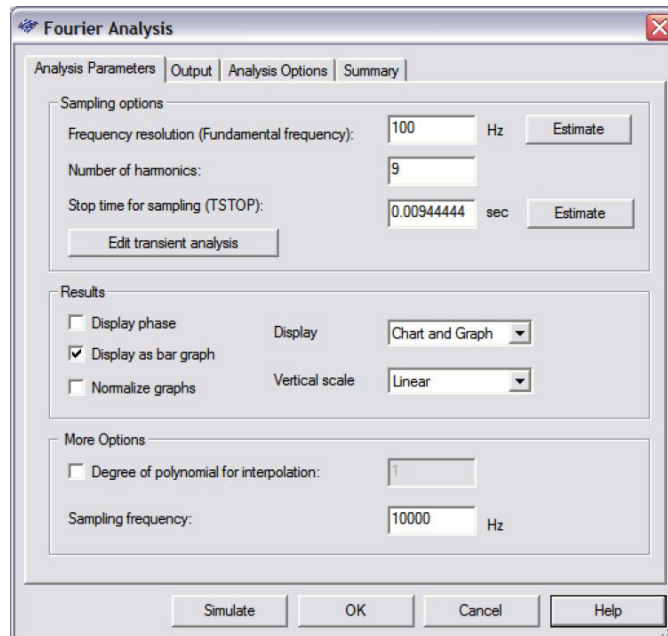

Figure 3.58: Waveforms displayed in the oscilloscope windows.

We now add an oscilloscope to the circuit (see Fig. 3.56). To run the oscilloscope we first give the parameters for the interactive simulation in the window that opens after Simulate→Interactive Simulation Settings..., shown in Fig. 3.57. We give the same TSTOP value of 0.01 sec as before. After clicking OK to close this window we click on the Run button to see that same waveform as before but now in the oscilloscope (see Fig. 3.58).



**Figure 3.59:** Specifications for Fourier analysis.

We now perform a Fourier analysis to see the distortion at the output signal. From Simulate→Analyses→Fourier Analysis.... we obtain the dialog window of Fig. 3.59. Since the input signal has a frequency of 100 Hz we use this value as the fundamental frequency and for TSTOP we press the button Estimate. After pressing the button Simulate we obtain the Fourier plot of Fig. 3.60 where we see the rich harmonic content of the output signal.

We now add a Distortion Analyzer as shown in Fig. 3.61. After setting the virtual instrument to use 9 harmonics by pressing the button Set and using the Run Button in Multisim we see that the measured distortion is 39.133%. This same result was obtained in the Fourier analysis.

### 3.7 CONCLUSIONS

Time domain simulations have been covered in this chapter. This type of analysis is called Transient Analysis. This analysis is useful when the circuit includes either inductors or capacitors or both. We

Example3-6-3

3	No. Harmonics:	9	
4	THD:	39.024 %	
5	Gridsize:	256	
6	Interpolation Degree:	1	
7			
8	Harmonic	Frequency	Magnitude
9	1	100	7.92431
10	2	200	0.0468649
11	3	300	2.41236
12	4	400	0.0468347
13	5	500	1.43784
14	6	600	0.0461386
15	7	700	1.0217
16			

Fourier Analysis

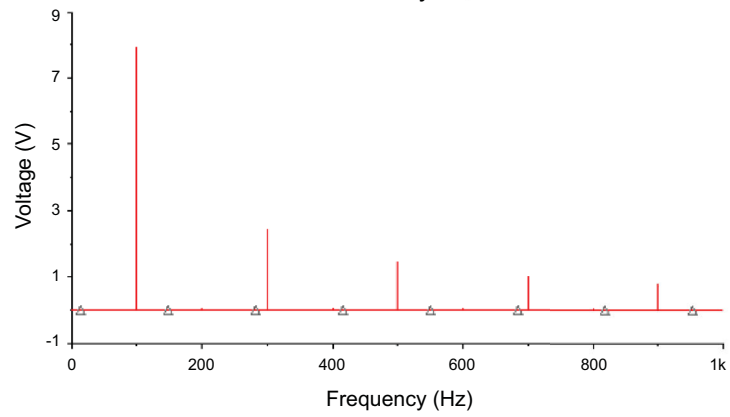
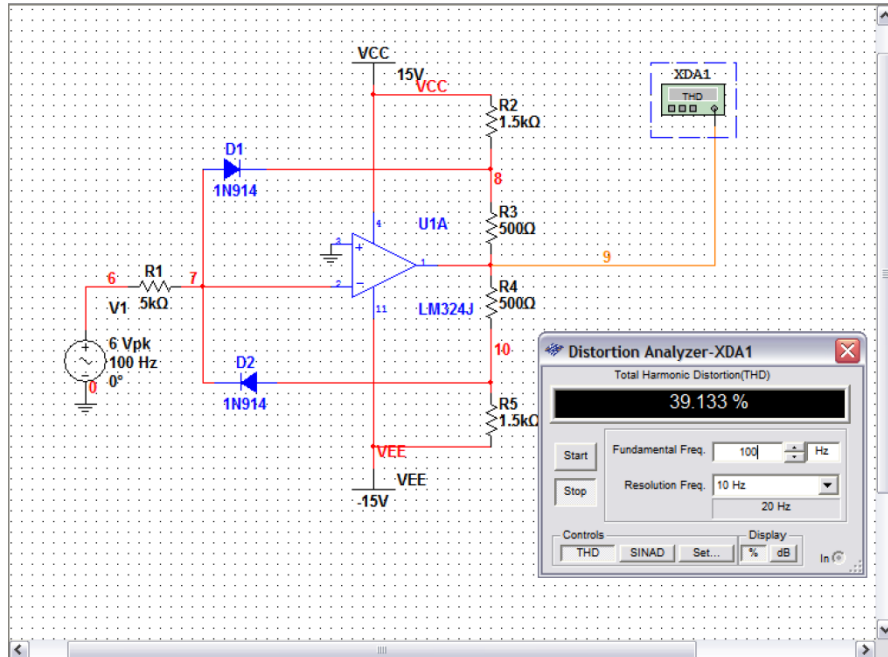

Figure 3.60: Fourier analysis results for the output voltage.



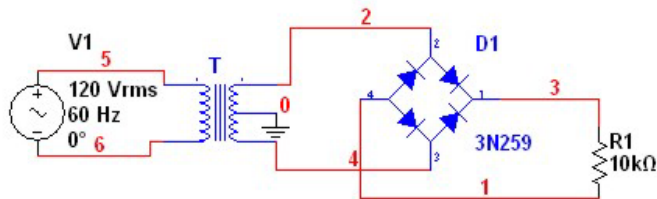

**Figure 3.61:** Comparator circuit with a Distortion Analyzer to measure THD of the output signal.

also covered how to perform a Fourier analysis to measure the harmonic content in the signals in a circuit. The oscilloscope and distortion analyzer instruments were introduced.

## PROBLEMS

- 3.1. Perform a transient analysis to the circuit shown. It is a full-wave rectifier.



- 3.2. Perform a Fourier analysis to the circuit of Problem 3.1.

84 3. TIME DOMAIN ANALYSIS – TRANSIENT ANALYSIS

- 3.3. Perform a transient analysis. Observe what happens to the signal after removing the capacitor. Use TSTOP = 0.1 sec and plot the signal at nodes 1 and 4.

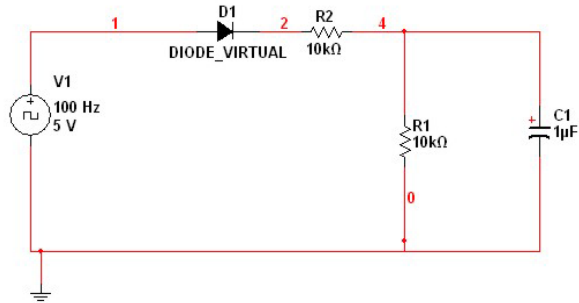

- 3.4. For the circuit shown, plot the node voltages V(1) and V(4).

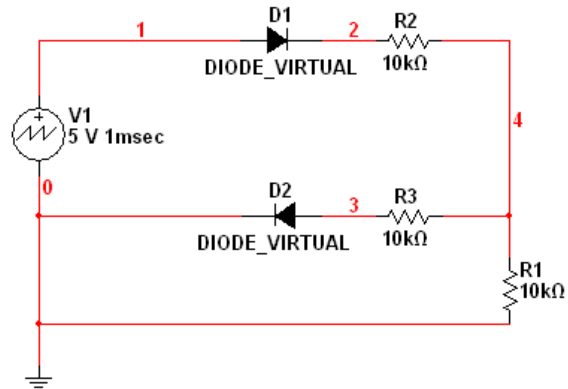

- 3.5. Use an oscilloscope to watch the signal at the circuit of Problem 3.3. Use the Run icon to simulate.
- 3.6. Run a transient analysis in the circuit shown. Change the voltage source to a square signal.

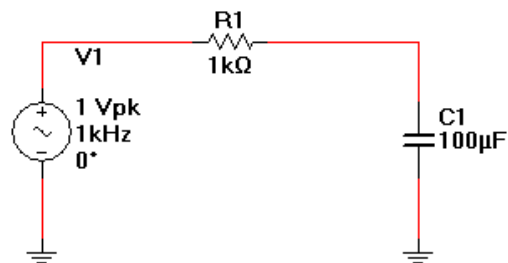

- 3.7. In the circuit shown, run a distortion analysis using the distortion analyzer from the Instrument toolbar and compare the result with the THD from a Fourier analysis.

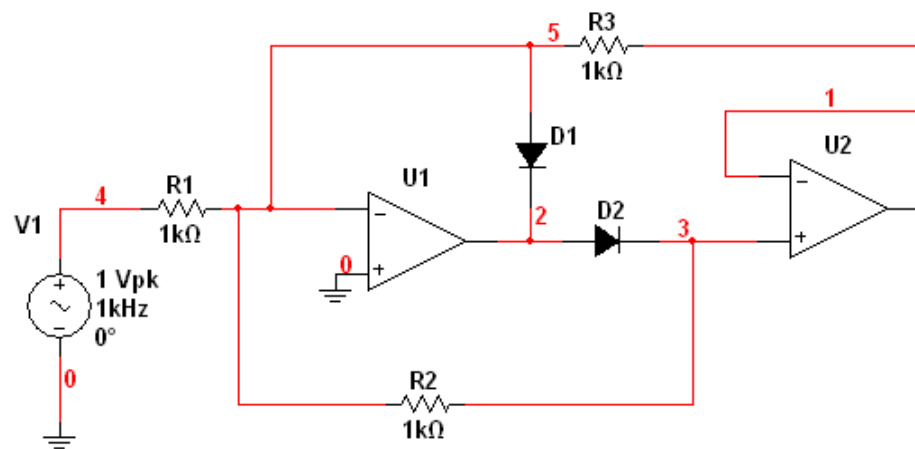



# Frequency Domain Analysis – AC Analysis

This chapter presents techniques to perform analyses in the frequency domain. These analyses go from getting the frequency response, Bode plots, and pole-zero analyses. These type of analyses are used in communication circuits, filter circuits, control systems, analog and digital signal processing, to mention a few.

## 4.1 AC ANALYSIS – FREQUENCY RESPONSE

An AC analysis is very useful in circuit analysis. It is used to obtain the frequency response of a circuit. It requires a frequency sweep. The analysis to obtain a frequency response is done in Multisim by selecting Simulate→Analyses→AC Analysis, as shown in Fig. 4.1. This opens the dialog window of Fig. 4.2 where we specify the Start Frequency FSTART, the Stop Frequency FSTOP, the sweep type, the number of points in the sweep, and the type of frequency scale for the vertical axis. In this case, we specify the sources giving the parameters in the AC analysis part. After giving the data for the AC analysis and the sources, we select the variables to plot and press the button simulate to obtain plots of the frequency response. The frequency response plots are also known as Bode plots.

The Sweep type can be anyone of the following types: Linear, Octave, and Decade. In a Linear sweep, the frequency range given by FSTOP-FSTART is divided by the number of points. In an Octave sweep (an octave is the frequency range that starts at frequency F and ends at frequency 2F), each octave is divided by the Number of points. In a Decade sweep (a decade is the frequency range that starts at frequency F and ends at frequency 10F), each decade is divided by the Number of points. In the case of octaves and decades, the START frequency must be different from zero.

After specifying the data for the AC analysis we choose the variables to be plotted and press the button Simulate. An example will show this procedure.

### Example 4.1 RLC Passive Circuit.

Let us consider the RLC normalized passive circuit of Fig. 4.3 (a). The voltage source is a sine wave with a frequency value from FSTART up to FSTOP. After wiring the circuit in Multisim we obtain Fig. 4.3 (b) we double click on the voltage source to give the parameters of it. The parameters of the AC voltage source are those indicated within the square in Fig. 4.4. In this example, we only specify the AC amplitude as unity. Next, we specify the parameters of the AC Analysis by selecting Simulate→Analyses→AC Analysis... to obtain the dialog window of Fig. 4.5. We set a

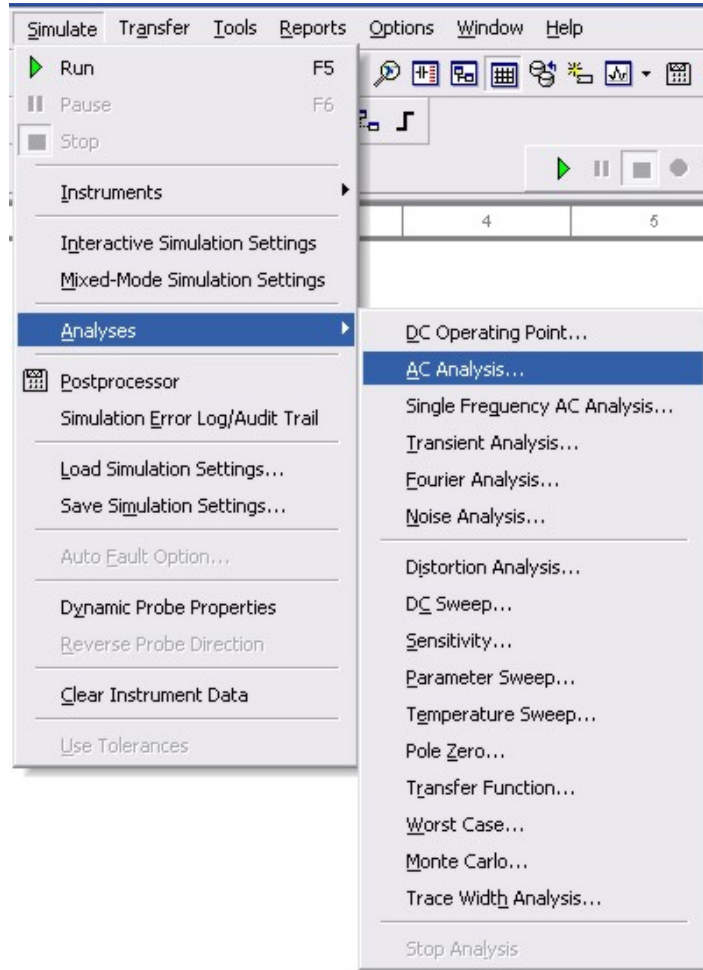

Figure 4.1: Selecting an AC analysis.

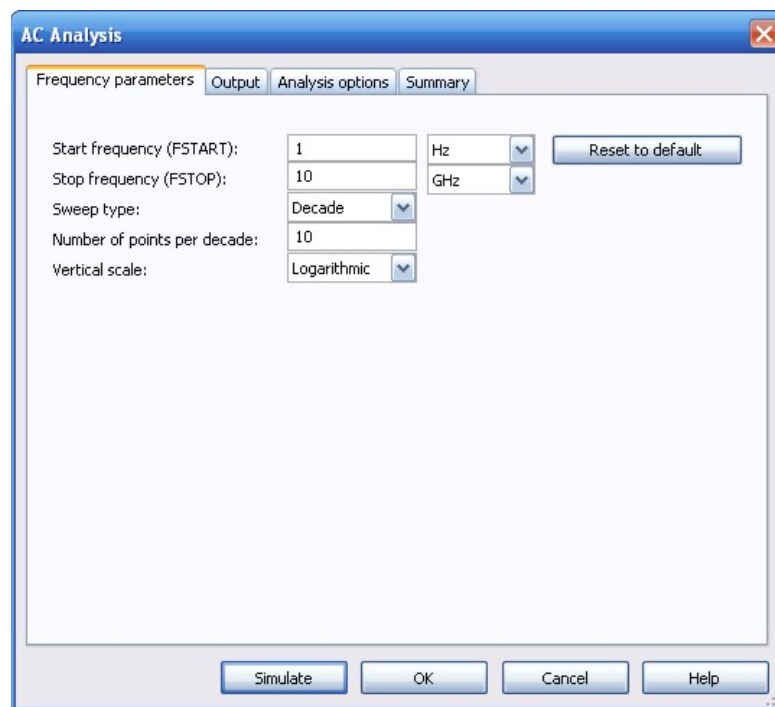
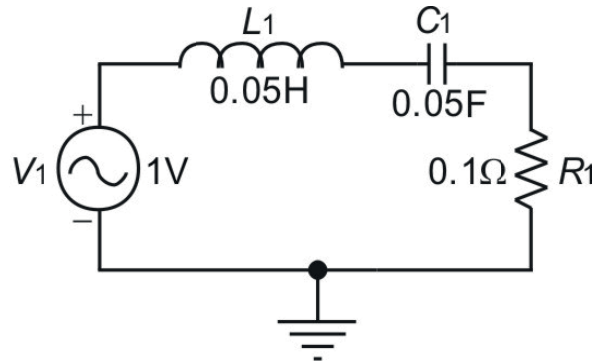
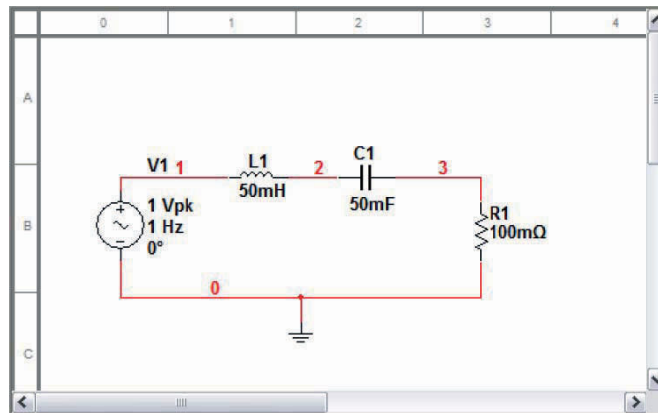

Figure 4.2: Dialog window for AC analysis.



(a)



(b)

**Figure 4.3:** Normalized RLC passive circuit. (a) Schematic diagram; (b) circuit in Multisim.

Linear sweep with 1000 points. The starting frequency is 2 Hz and the final one is 5 Hz. The output variable to plot is the voltage at node 3, that is,  $V(3)$ . After pressing the button Simulate we obtain the plots of Fig. 4.6. These are the magnitude and phase of the signal at node 3. We see that the RLC circuit is a passband filter.

In Multisim, before doing the AC analysis or any other analysis, a Bias Point analysis is done. If for any reason a Bias Point cannot be done, the simulation is aborted and error messages will be displayed.



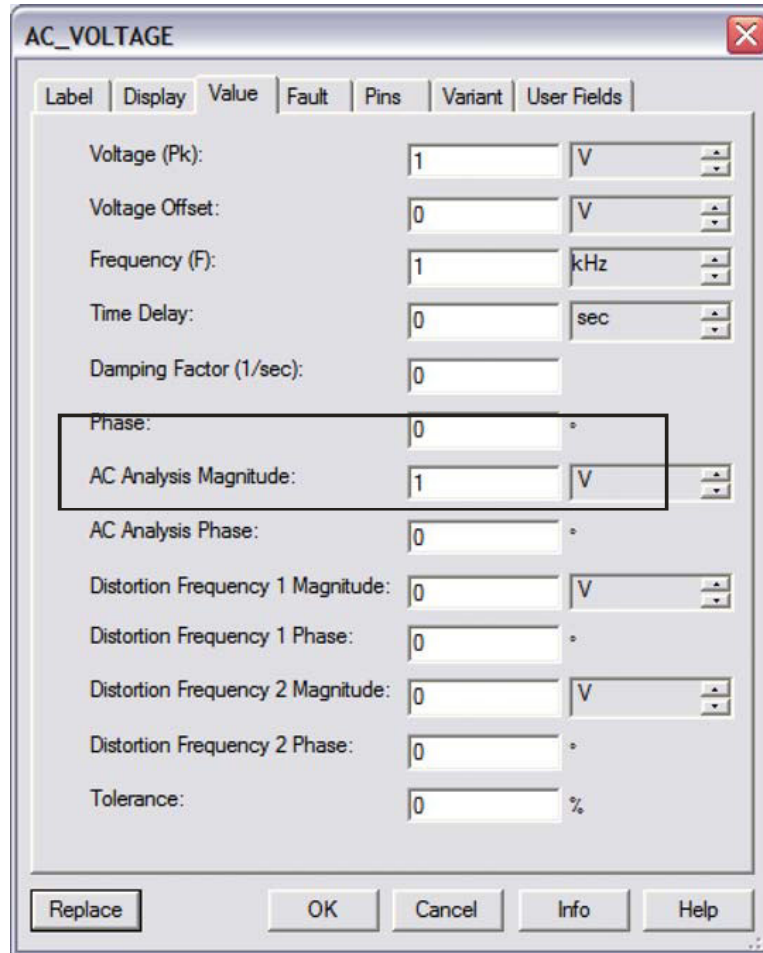

**Figure 4.4:** Dialog window to specify the amplitude of the AC signal. The data for AC analysis is within the square.

#### 4.1.1 LOOPS WITH NO RESISTANCE

In Multisim, inductors and voltage sources are ideal with zero internal resistance. For a Bias Point analysis all the loops have to have a non zero resistance. If a loop has zero resistance an error message will be displayed. To correct the problem, we have to insert a small resistance to have a successful analysis. We show this with an example.

##### **Example 4.2 Circuit with a zero resistance loop.**

Let us consider the circuit in Fig. 4.7 (a). The circuit has a loop with zero resistance because the inductors and the AC voltage source have zero internal resistance. When running this circuit

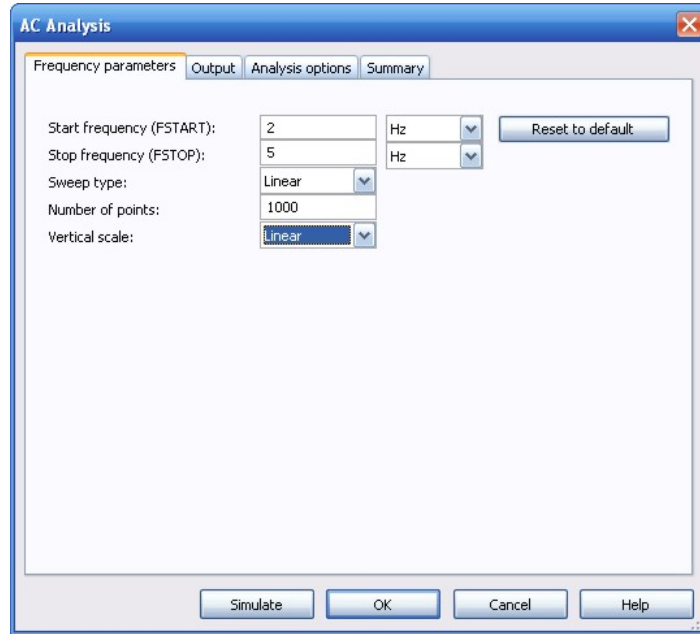

Figure 4.5: Dialog window to specify the parameters of the AC analysis.

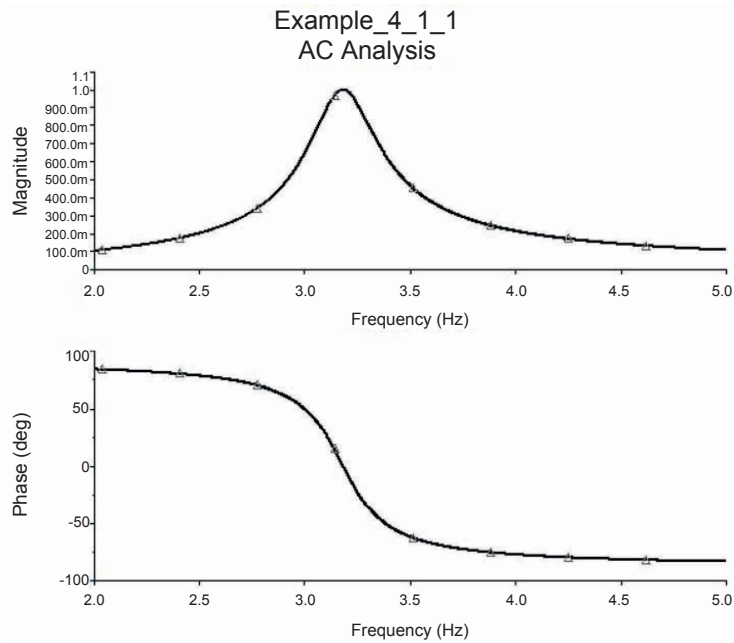
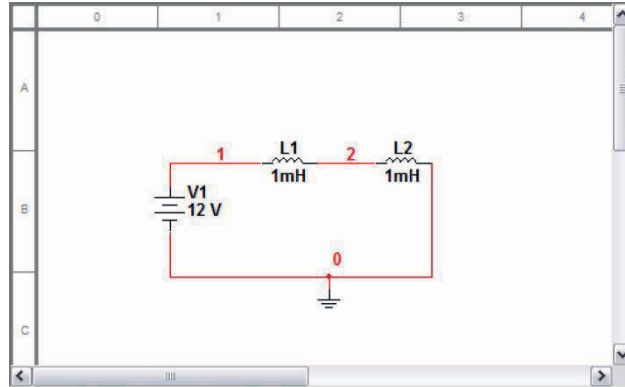
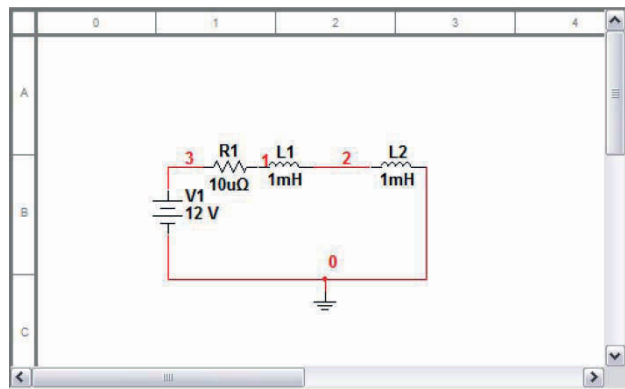

Figure 4.6: Magnitude and phase plots of the RLC circuit.



(a)



(b)

**Figure 4.7:** (a) The loop has zero resistance; (b) very small value resistor R1 avoids the zero resistance loop.

we obtain the message window of Fig. 4.8 which indicates that the analysis has been aborted. This problem can be avoided by inserting a very small resistor in the loop. In Fig. 4.7 (b), we inserted in the loop a  $1\mu\Omega$  resistor to avoid the zero resistance loop. The value of the resistor is very small in order not to affect circuit behavior but allows Multisim to obtain the Bias Point analysis.

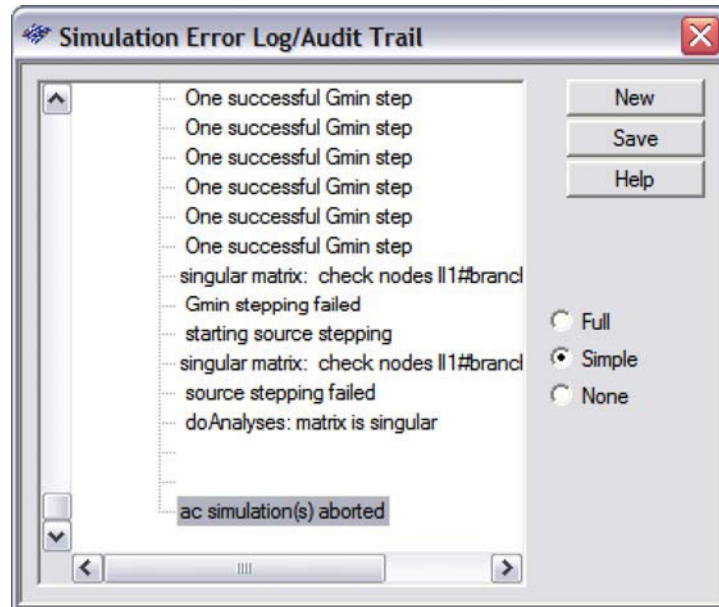

**Figure 4.8:** Message window indicating that the analysis has been aborted because of the presence of a zero resistance loop.

## 4.2 BODE PLOTS

A Bode plot is a set of two graphs. A graph is of signal magnitude in dB versus frequency and the second graph is phase against frequency. In this way, Fig. 4.6 is a Bode plot. Bode plots are obtained by performing an AC analysis on a circuit and plotting a voltage or current. Multisim then displays the Bode plot of that signal. The frequency range is usually specified in either in decades or octaves but it can also be specified in a linear scale.

### Example 4.3 Bode plots for a passive ladder filter.

Let us consider the circuit of Fig. 4.9 (a). It is a frequency normalized passive ladder filter.

We wish to find the frequency response. We specify a linear sweep with 100 points as seen in the dialog window of Fig. 4.9 (b). After running the analysis we obtain the Bode plots of Fig. 4.10. We can see there the magnitude and phase plots. We can obtain a Bode plot by using the Bode plotter from the Instruments toolbox. We select the Bode plotter with a click and bring it to the circuit where we connect it as desired (see Fig. 4.11). The window next to the circuit is open by

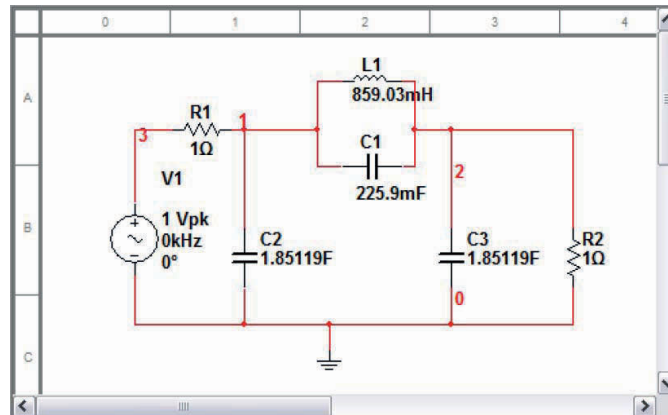

(a)

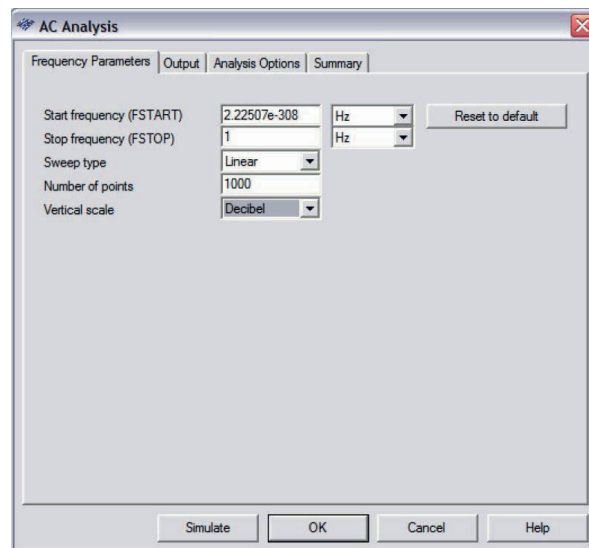

(b)

**Figure 4.9:** Passive ladder circuit. (a) Schematic circuit; (b) dialog window to specify the AC analysis.

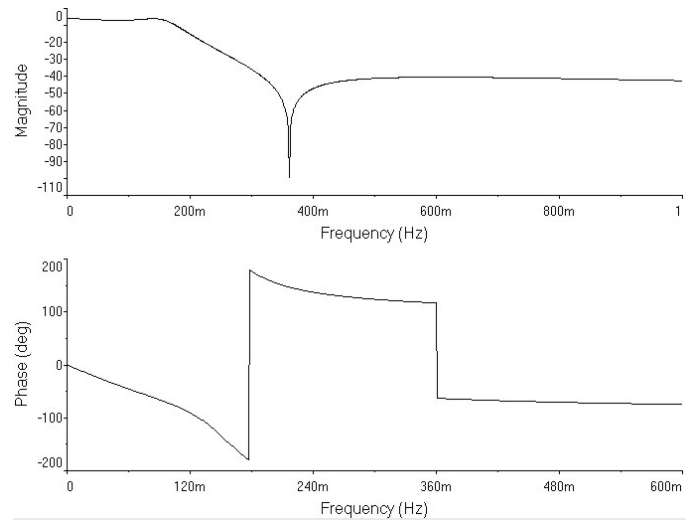

Figure 4.10: Frequency response plots.

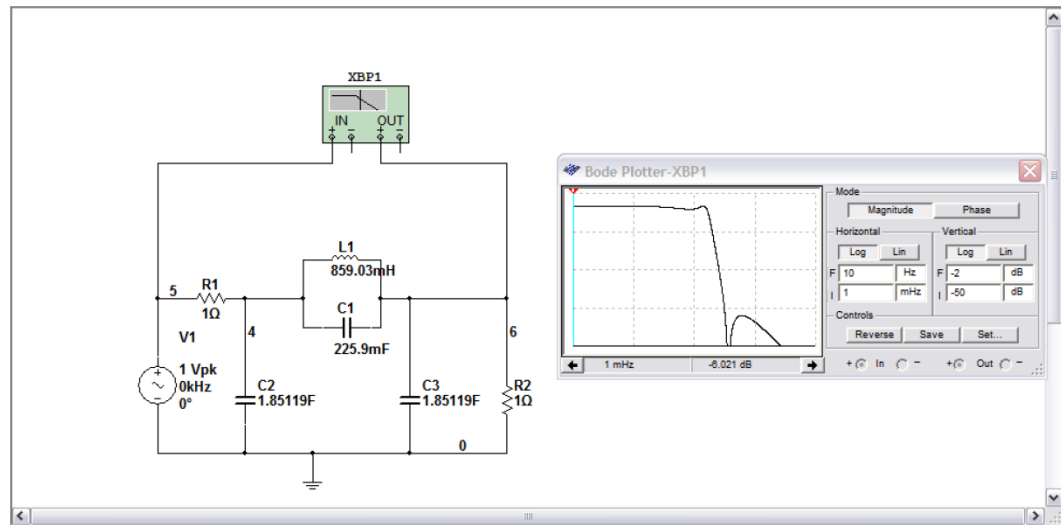
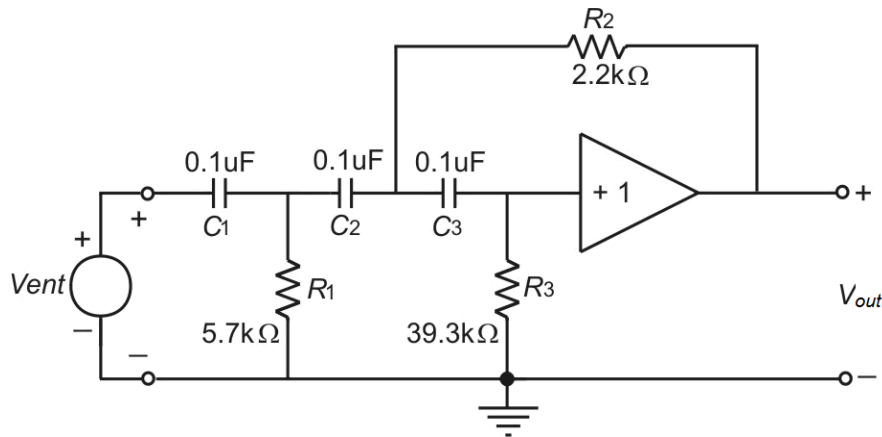

Figure 4.11: Circuit with Bode plotter.

double clicking on the Bode plotter. Then we press the Run button, or F5, and the Bode plot appears on the window of the Bode plotter as shown in Fig. 4.11.

**Example 4.4 High pass active filter.**

Fig. 4.12 is a third-order high pass active filter. It is composed of three resistors, three capac-



**Figure 4.12:** Filtro activo pasa altas.

itors, and a unity gain amplifier. We wish to obtain the frequency response. We then wire up the circuit in Multisim to obtain Fig. 4.13. We wish to obtain Bode plots for the output voltage  $V_{out}$  which in this circuit corresponds to  $V(5)$ .

We realize the unity gain amplifier with an operational amplifier in a voltage follower configuration. After performing an AC analysis we obtain the plots shown in Fig. 4.14. We can readily see that we have a high pass filter.

### 4.3 POLE-ZERO ANALYSIS

Electric and electronic circuits, when analyzed in the frequency domain, are characterized by a transfer function. A transfer function usually is defined as the ratio of an output variable divided by an input variable. For circuits composed by lumped elements, like the circuits treated in this book, the transfer function is a rational function of the complex frequency variable  $s$ , where  $s$  is the variable in the Laplace transform. To be a rational function means that the transfer function is the ratio of two polynomials in  $s$ . These two polynomials are called numerator and denominator polynomials. The roots of these polynomials are called zeros, for the numerator polynomial, and poles for the denominator polynomial. Multisim has the capability of finding the poles and zeros of a circuit, and from there, we can form the transfer function, regardless of the complexity of the circuit topology.

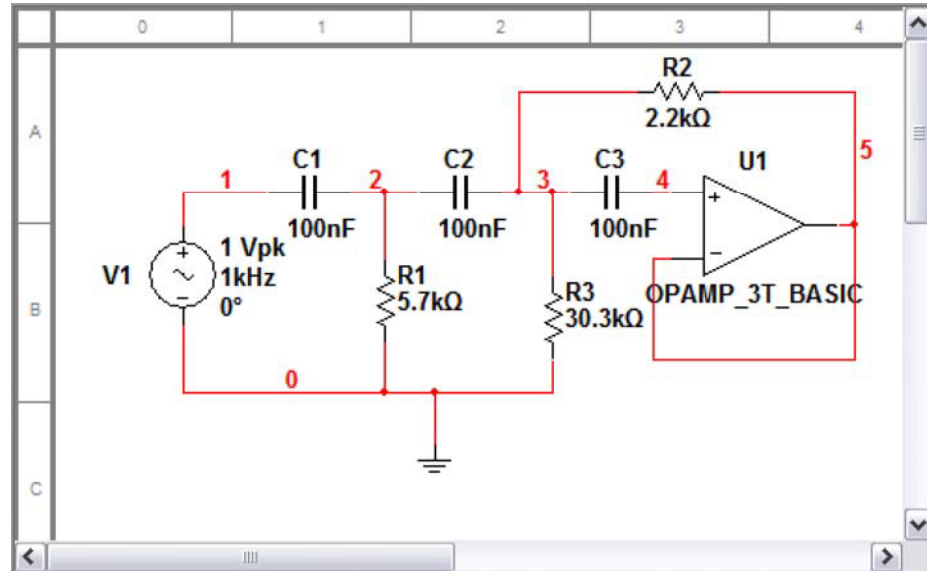

**Figure 4.13:** Circuit in Multisim.

Multisim can make a Pole-zero analysis by selecting from the main menu Simulate→Analyses→Pole Zero... as shown in Fig. 4.15. This action will open the dialog window of Fig. 4.16 where we specify the function for which we wish to obtain poles and zeros. We also need to specify input and output variables for the desired function. In Fig. 4.16, we see that we can obtain the voltage transfer function as Gain Analysis, the impedance transfer function as Impedance Analysis, and the input and output impedances. An example will show the procedure.

**Example 4.5 Poles and zeros of an active RC circuit.**

Let us consider the circuit of Example 4.3 repeated here as Fig. 4.17. We now know that it is an elliptic low pass filter of the elliptic type. As such, according to the Bode plot, it has to have zeros at the  $j\omega$  axis. After selecting from the Simulate menu Simulate→Analyses→Pole Zero, the window of Fig. 4.18 opens. There we enter the input and output port nodes which in this circuit are V(1) and V(0) for the input port and V(Vout) and V(0) for the output port. After clicking on the Simulate button we have the results shown in Fig. 4.19. There we see that there are three poles and two zeros. The poles are:

- 0.54019307
- 0.21710906 +  $j$  0.98174004
- 0.21710906 –  $j$  0.98174004 ,



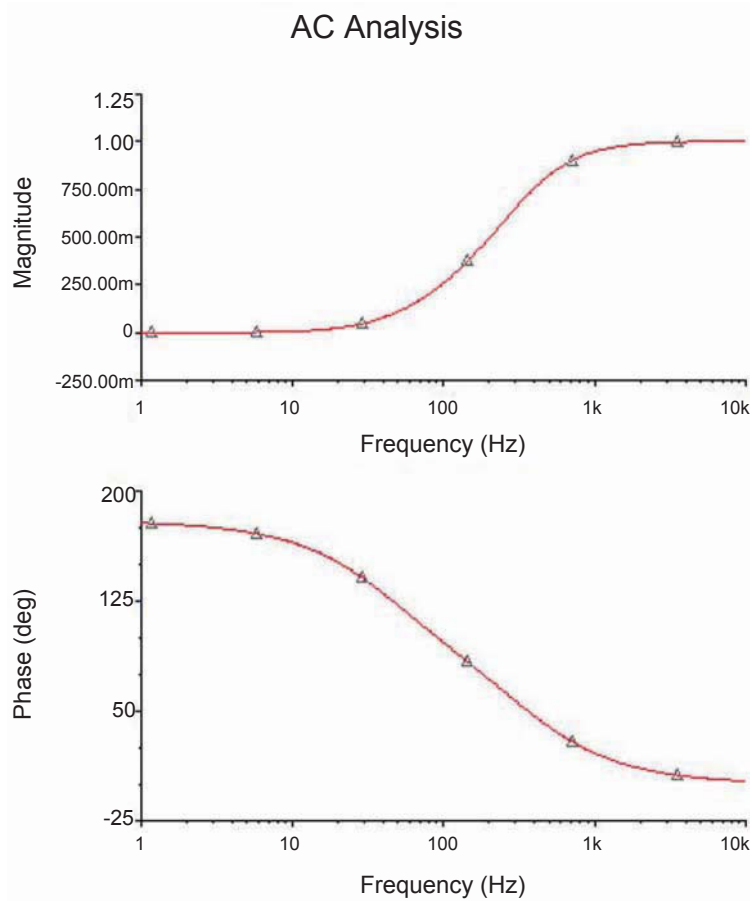

**Figure 4.14:** Bode plots for the high pass active filter.

and the zeros are:

$$\begin{aligned} &+ j 2.27006 \\ &- j 2.27006 . \end{aligned}$$

With this information we obtain the transfer function given by

$$N(s) = \frac{(s + j 2.27006)(s - j 2.27006)}{(s + 0.54019307)(s + 0.21710906 + j 0.98174004)(s + 0.21710906 - j 0.98174004)} .$$

After some algebra,  $N(s)$  simplifies to

$$N(s) = \frac{s^2 + 5.153172}{s^3 + 0.974411 s^2 + 1.198375 s + 0.520645} .$$

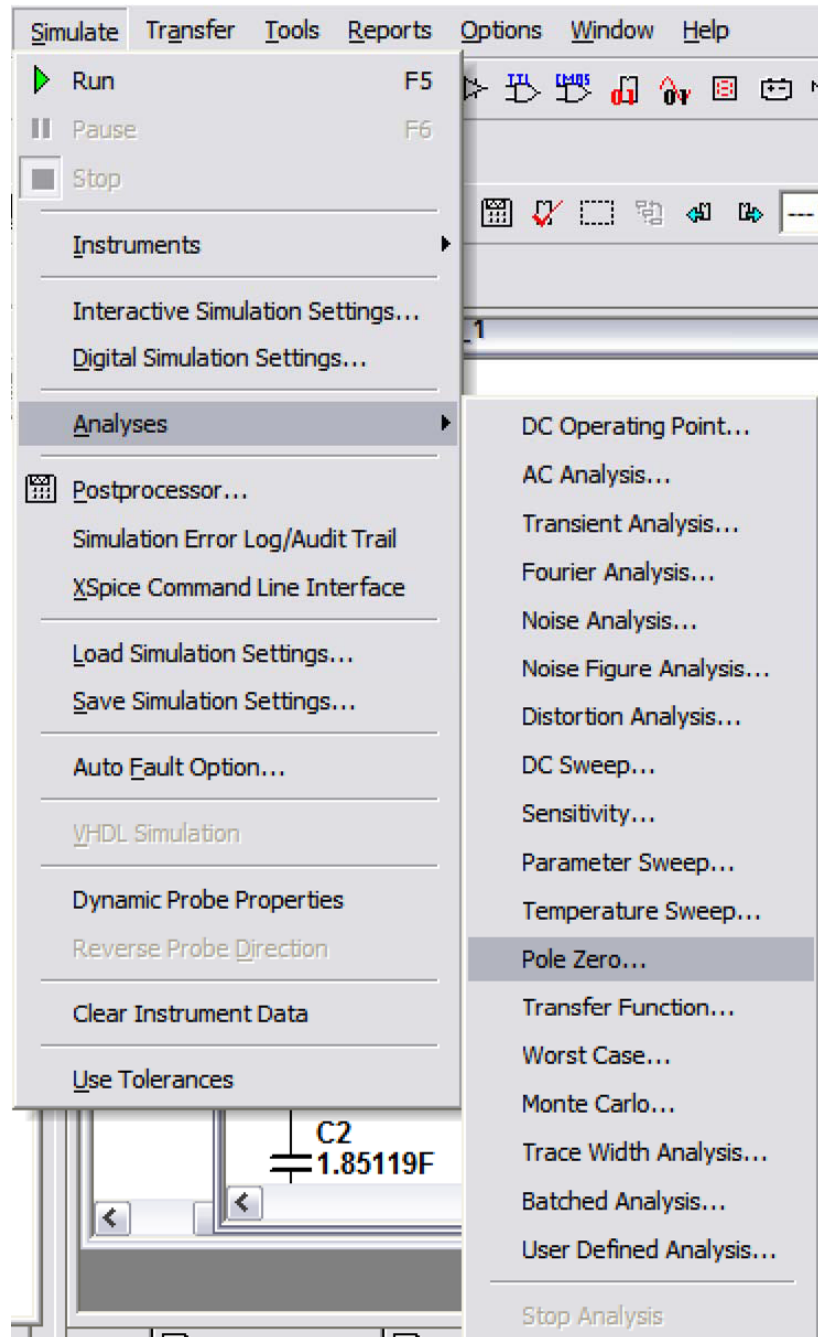

Figure 4.15: Menu to obtain a Pole Zero analysis.

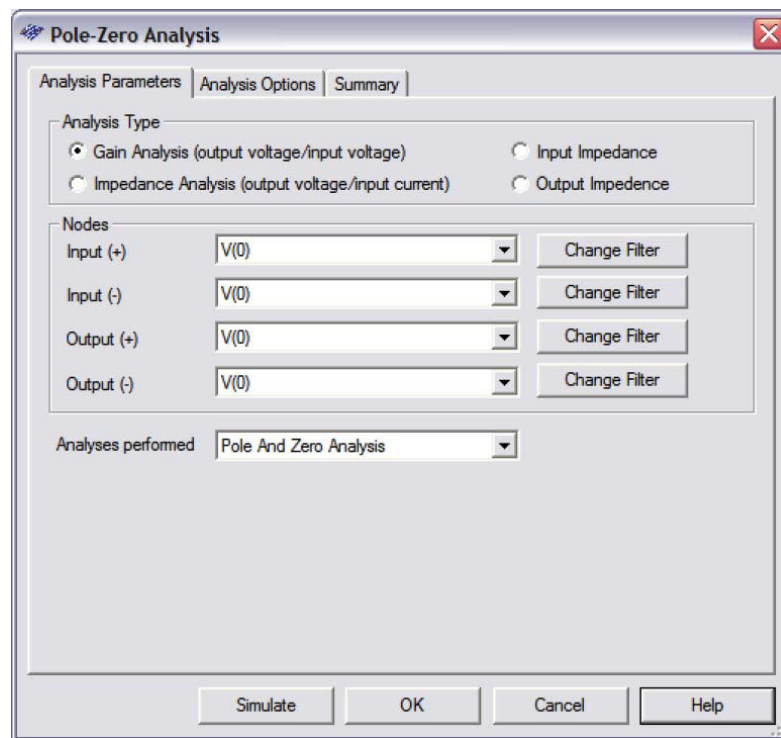

Figure 4.16: Window for data in Pole Zero analysis.

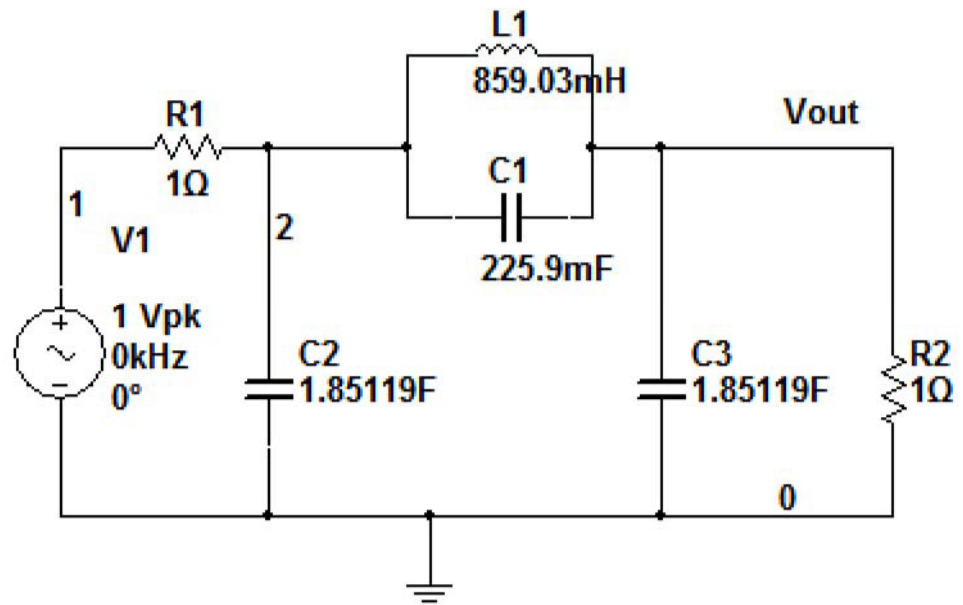

Figure 4.17: Passive ladder elliptic filter for Pole Zero analysis.

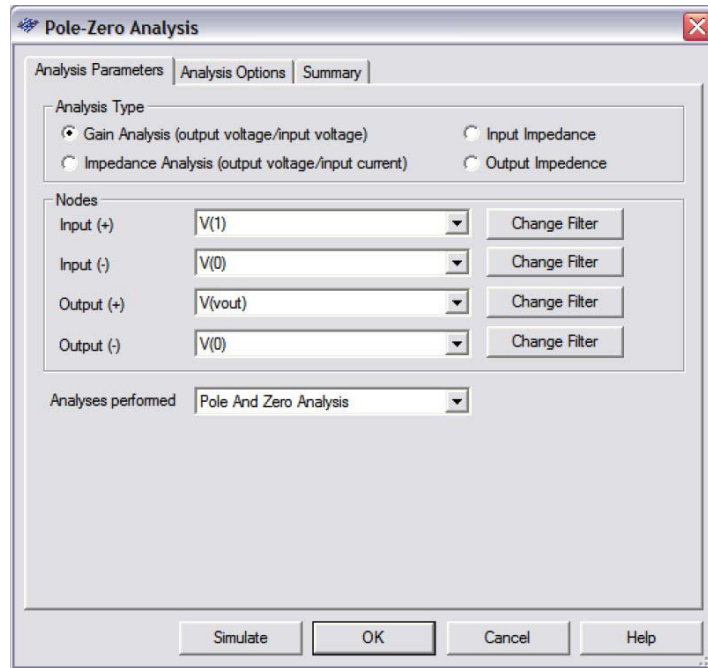

Figure 4.18: Input and output nodes for Pole Zero analysis.

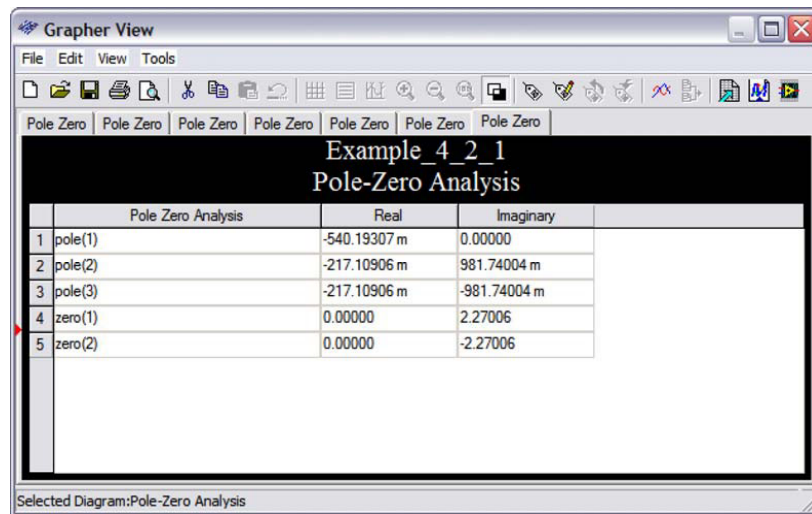

Figure 4.19: Poles and zeros for the passive ladder elliptic filter.

## 4.4 EXAMPLES

In this section, we present additional examples of circuits where an AC analysis is made.

### Example 4.6 Circuit with two operational amplifiers.

Fig. 4.20 shows a circuit with two operational amplifiers. This is an active filter and we wish to find out which type of filter is.

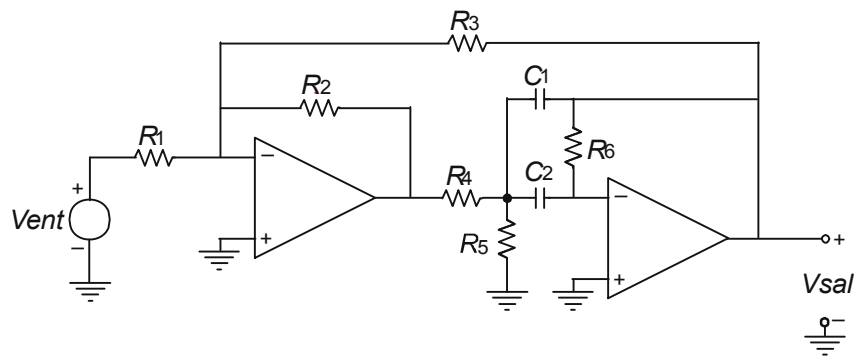

**Figure 4.20:** Circuit with two operational amplifiers.

In this circuit we are using 741 operational amplifiers available from the Op Amps group. These op amps need a dual power supply. The circuit in Multisim is shown in Fig. 4.21. The data for the AC analysis can be seen in the window of Fig. 4.22. The frequency response is plotted in Fig. 4.23. From there we see that the filter is a passband one.

We now add a Bode plotter from the Instruments toolbar as shown in Fig. 4.24. The Bode plotter input and output are connected to the circuit input and output nodes. We then press the Run button and after a few moments we see the Bode plot displayed in the Bode Plotter as shown in Fig. 4.25.

### Example 4.7 Phase shift oscillator.

Fig. 4.26 shows a phase shift oscillator. In order to oscillate, this circuit requires that the phase difference between the op amp output and point B to be  $180^\circ$  in addition to a unity gain from point A to point B. These two conditions are known as the Barkhausen criterion. The oscillation frequency is given by

$$f_0 = \frac{1}{2\pi RC\sqrt{6}}.$$

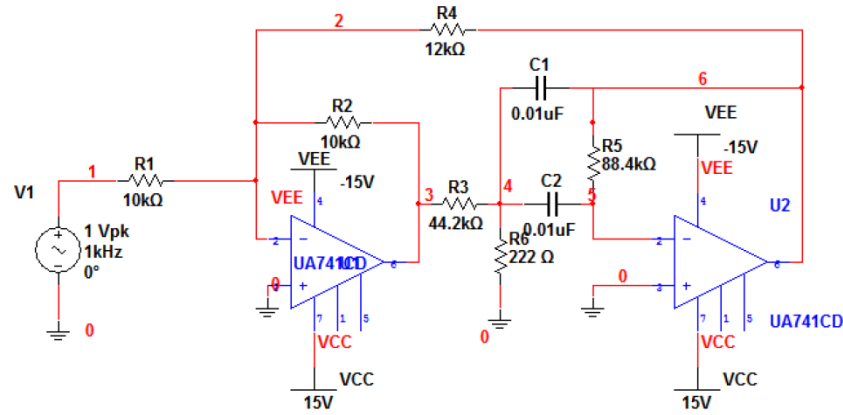

**Figure 4.21:** Two op amp circuit in Multisim.

If we need this circuit to oscillate at a 100 Hz frequency, for  $C = 0.4 \mu\text{F}$ , then  $R$  must be 1.3 K $\Omega$ . An analysis of the circuit reveals that it has a gain of 1/29 at the chosen frequency of 100 Hz. Thus, the op amp circuit must have a gain of 29 (in practice a little bit higher to start the oscillation). Since  $R = 1.3 \text{ K}\Omega$  then  $R_f = 37.7 \text{ K}\Omega$ .

If we choose  $R_f$  1% greater than the calculated value above, we have then  $R_f = 38.077 \text{ K}\Omega$  which gives us a loop gain slightly higher than unity. In order to simulate the circuit, Multisim requires an independent signal source. To verify if this circuit will oscillate properly, we perform an indirect measurement. We open the circuit between the points A and B and place an independent voltage source with unity magnitude. Then we measure the magnitude gain from point A to point B. This gain must be unity. We also measure the phase. It has to be  $0^\circ$ .

Fig. 4.27 shows the circuit in Multisim.

To check that the circuit behaves as expected we perform an AC analysis from 60–140 Hz, as shown in Fig. 4.28. We plot the gain from node B to node A, that is, we plot the magnitude and phase of  $V(A)/V(B)$ . Fig. 4.30 shows the resulting plots. There we see that at approximately 100 Hz we have unity gain and  $0^\circ$  phase.

#### Example 4.8 Intermediate Frequency Filter.

Intermediate frequency (IF) filters are an important part of any communication system. They appear in any modern communication receivers such as AM and FM radios, TV sets, satellite communication systems, cellular telephony, software radio, etc. A typical topology for an IF filter is shown in Fig. 4.30 and it is composed of two coupled coils. The component values have been chosen in such a way that the resonant frequency is close to 1 KHz. We specify an AC analysis with a frequency range going from 800 Hz to 1.2 KHz. The frequency range is by octaves with 200 points

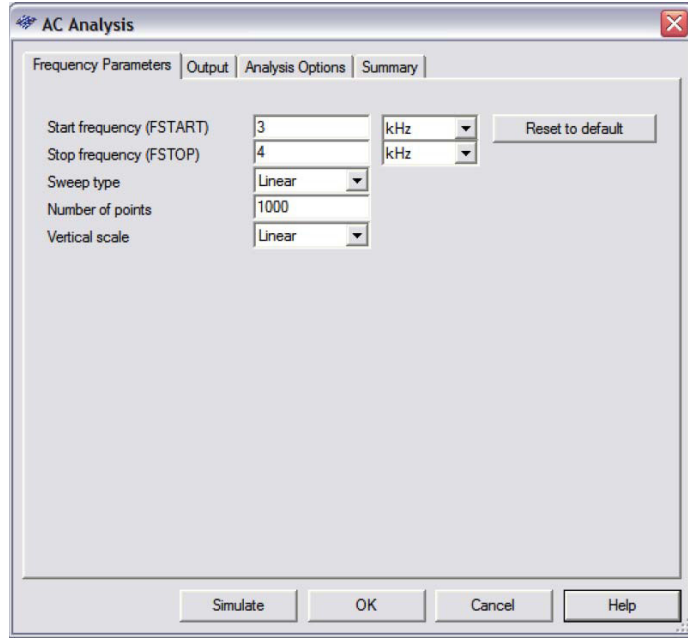

Figure 4.22: Data for the AC analysis.

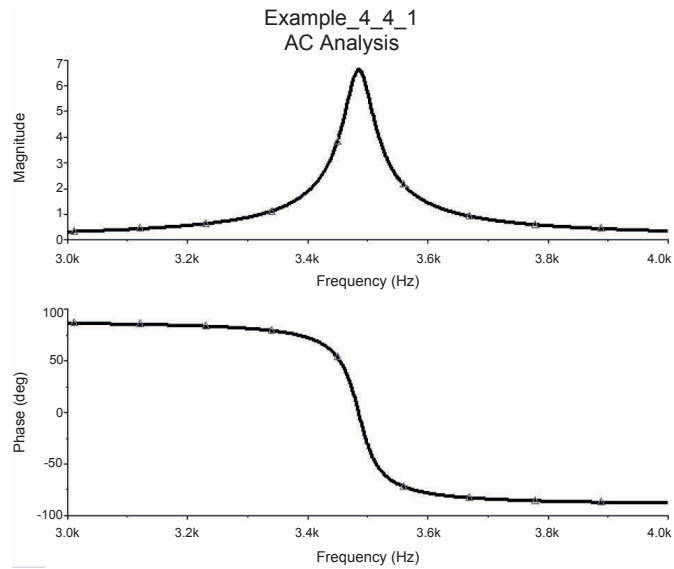

Figure 4.23: Frequency response plots for the two op amp circuit.



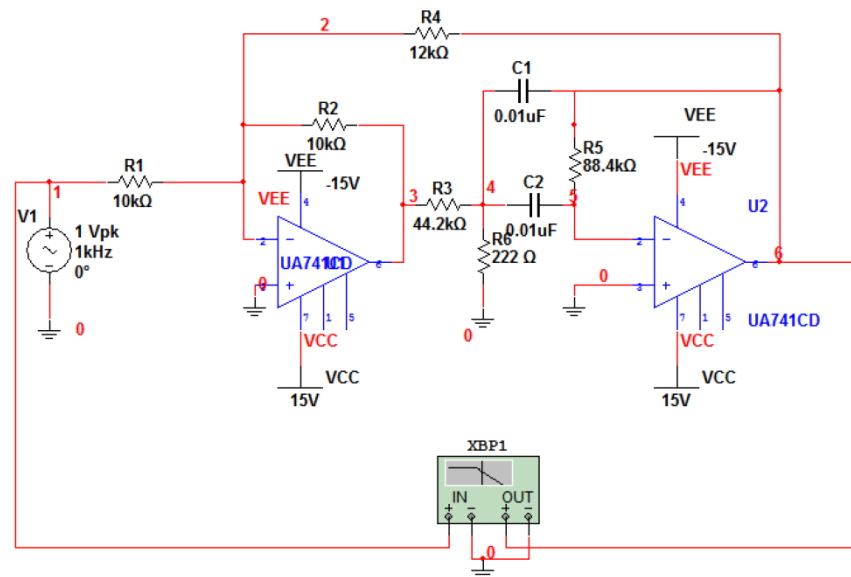

Figure 4.24: Two op amp circuit with a Bode plotter connected between input and output nodes.

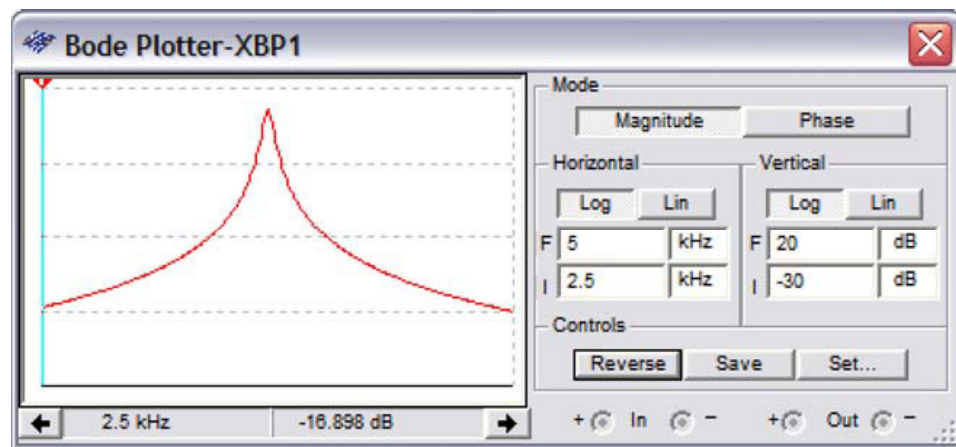

Figure 4.25: Bode plotter output.

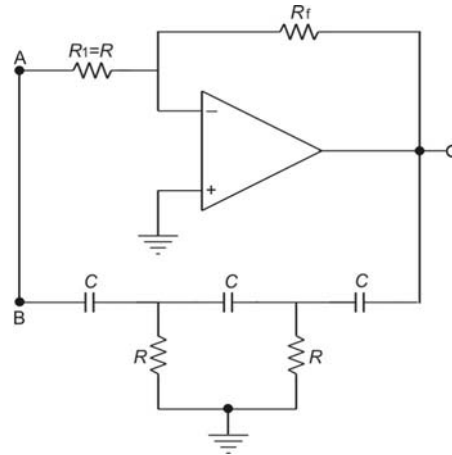

Figure 4.26: Phase shift oscillator.

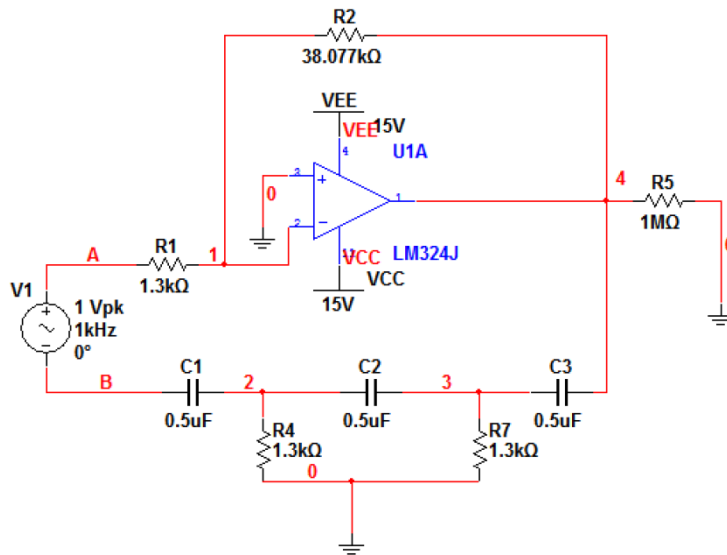

Figure 4.27: Phase shift oscillator in Multisim.

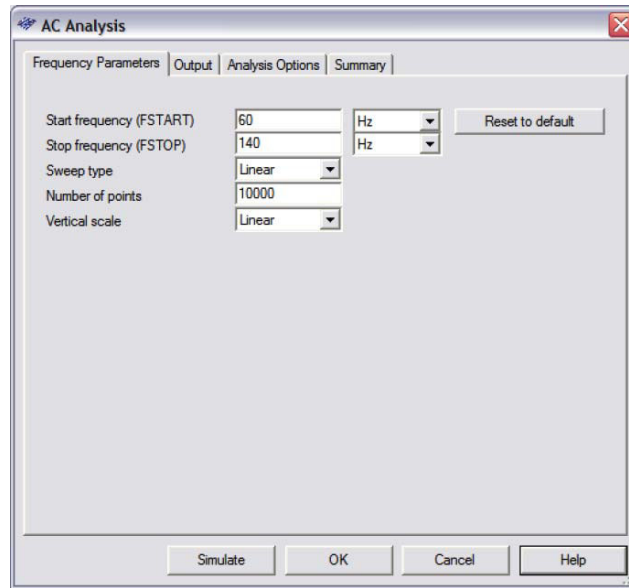

Figure 4.28: Data for AC analysis.

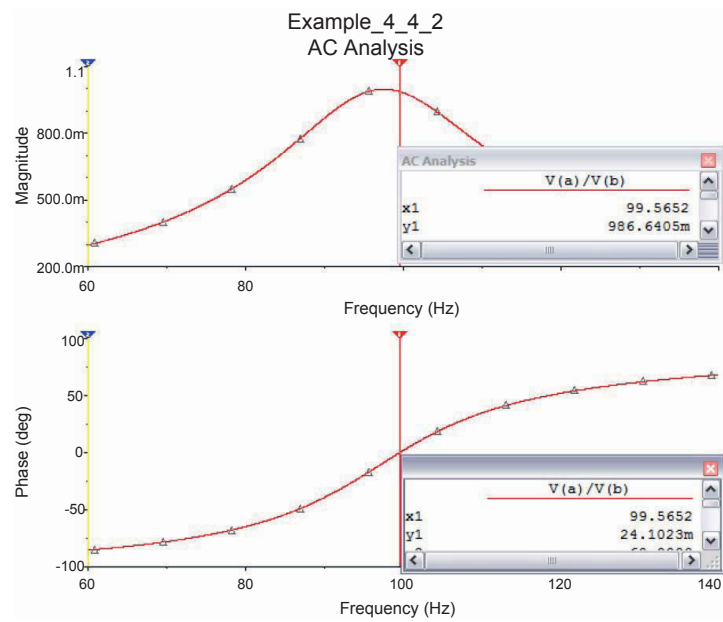

Figure 4.29: Magnitude and phase for the phase shift oscillator.

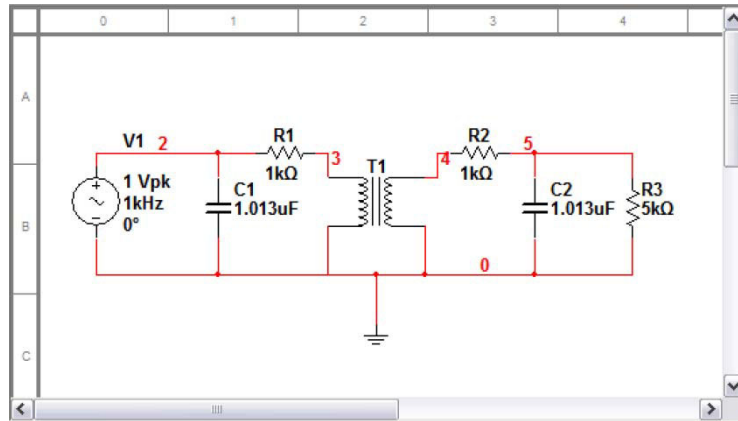

Figure 4.30: Intermediate frequency filter.

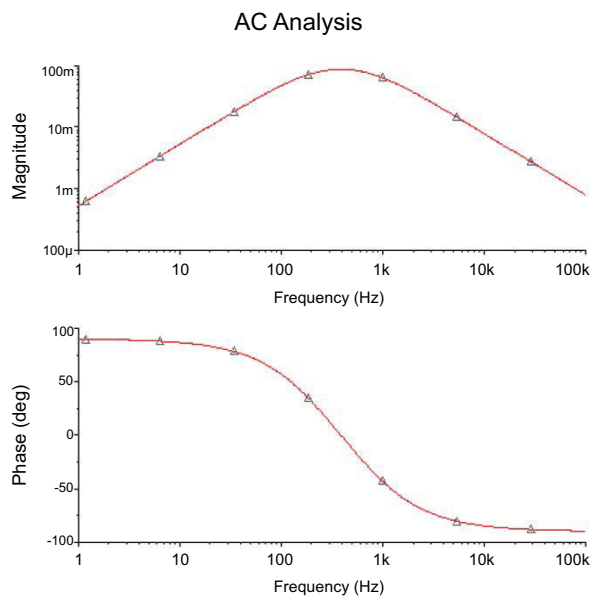

Figure 4.31: Plots for the voltage across the load resistor.

per octave. A plot of the voltage across R3 is shown in Fig. 4.31. The frequency response presents a bandpass behavior.

## 4.5 CONCLUSIONS

In this chapter we have presented the AC analysis and its main characteristics. Together with Bias Point, DC Sweep, and Transient Analyses we have the four basic types of analyses that can be done to a circuit. AC analysis is a frequency sweep to obtain frequency response plots of a circuit. These frequency response plots are usually called Bode plots and they can also be obtained with Multisim Bode Plotter available from the Instruments toolbar. We also presented the way to avoid loops with zero resistance that is not possible to simulate in Multisim. Other types of analyses, which can be done to a circuit, are based in anyone of the analyses types described so far.

## PROBLEMS

- 4.1. Plot the magnitude and phase of the circuit shown.

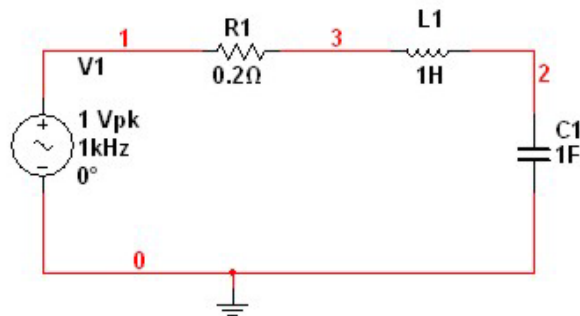

- 4.2. On the circuit of Problem 4.1, obtain the poles by making a pole-zero analysis.
- 4.3. The circuit shown is a multiple-feedback bandpass filter. Obtain the magnitude and phase for this circuit using an AC analysis. Also use the Bode plotter from the Instrument toolbar. Compare both plots. Use  $C_2 = C_3 = 0.1 \mu\text{F}$ ,  $R_1 = 15.9 \text{ K}\Omega$ ,  $R_5 = 79.97 \Omega$ ,  $R_6 = 31.83 \text{ K}\Omega$ . Use an op amp 741.

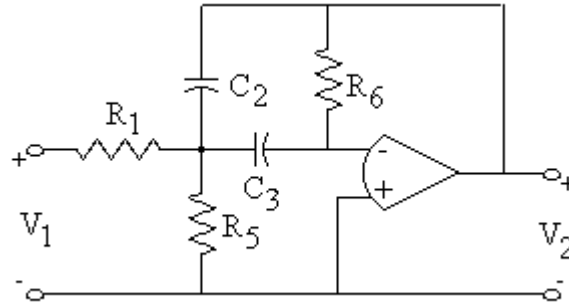

- 4.4. Obtain the frequency response, using an AC analysis for the circuit shown. Observe that it has transmission zeros. They are due to the tank LC circuits. The zeros must be located at  $f_0 = \frac{1}{2\pi\sqrt{LC}}$ . Compute the frequency for both tanks and compare the results with the ones obtained from the simulation.

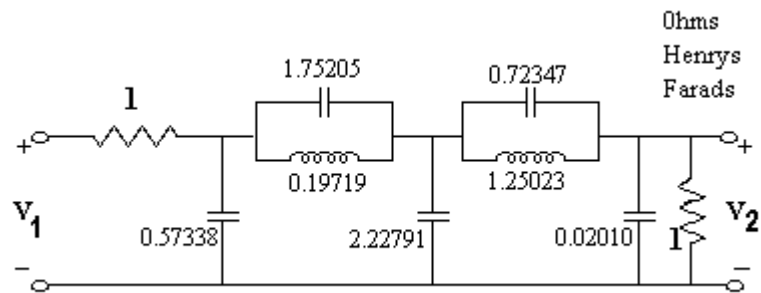

- 4.5. The circuit shown is a lowpass filter using two generalized immittance converters (GICs). Obtain the magnitude response for the circuit. Resistors are in  $K\Omega$  and capacitors in  $\mu F$ . Use Op amps 741.

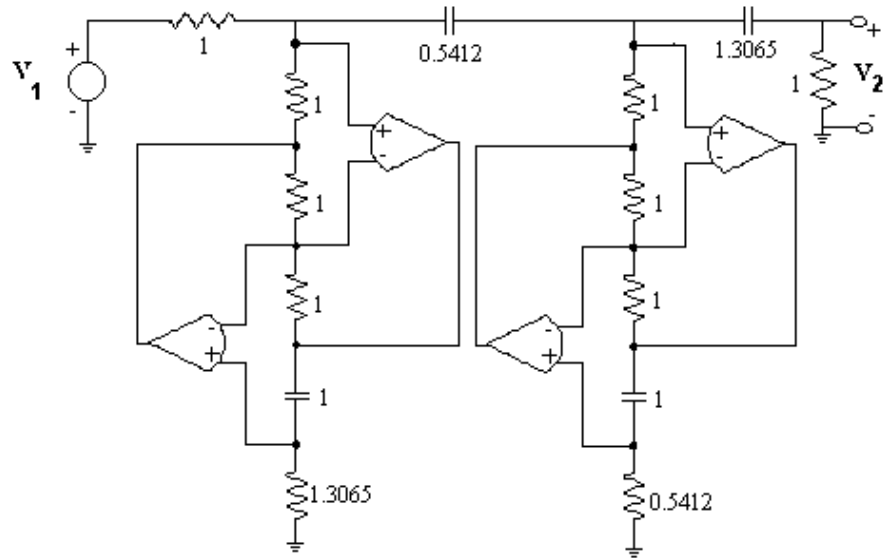

- 4.6. In the KHN state-variable filter shown, use 741 op amps. Plot the magnitude response at each of the op amp outputs. The element values are  $C_1 = C_2 = C = 1 \mu\text{F}$ ,  $R_1 = R_2 = R_3 = R_5 = R_6 = 1 \text{ K}\Omega$  and  $R_4 = 19 \text{ K}\Omega$ .

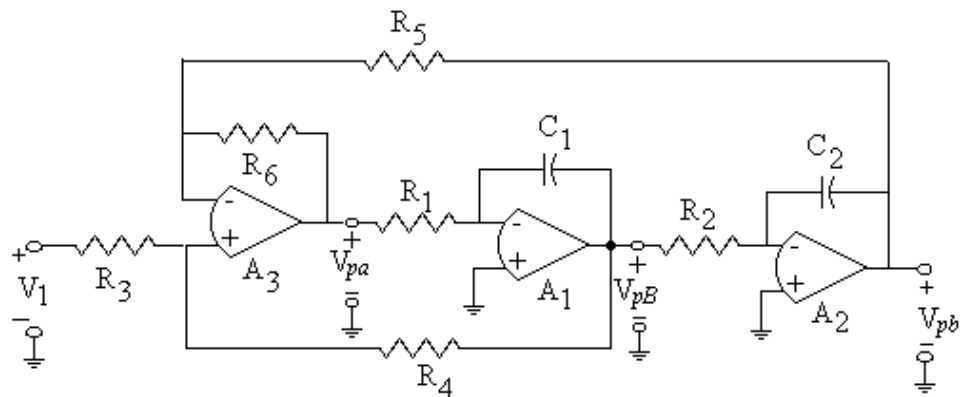

- 4.7. For the Tow-Thomas filter shown, run a simulation and plot the magnitude responses for the op-amp outputs. Compare them. Use the op-amp 741. The element values are  $C_1 = C_2 = C = 1 \mu\text{F}$ ,  $R_1 = 1.59 \text{ M}\Omega$ ,  $R = R_2 = R_3 = 159 \text{ K}\Omega$ ,  $R_4 = 795.77 \text{ K}\Omega$ . Use the Bode plotter and compare the results.

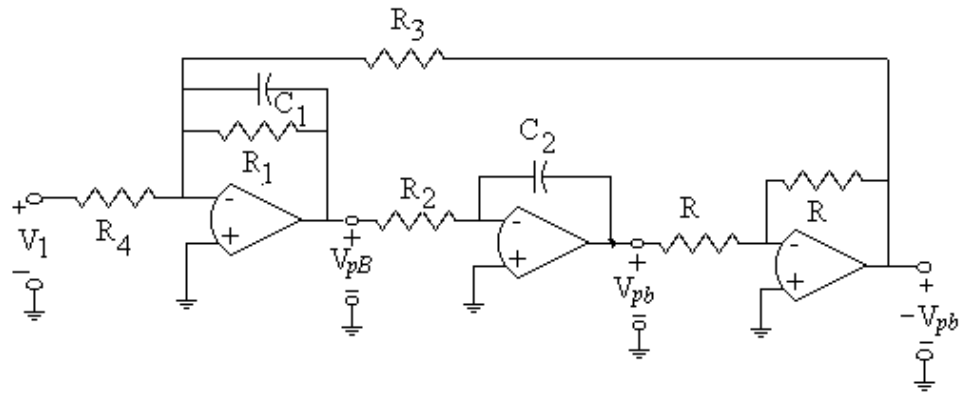

- 4.8. The circuit shown is a leap-frog filter. Obtain the Bode plot for the magnitude of  $V_2$ . Use the virtual op-amp. Resistors are in  $K\Omega$  and capacitors in  $\mu F$ .

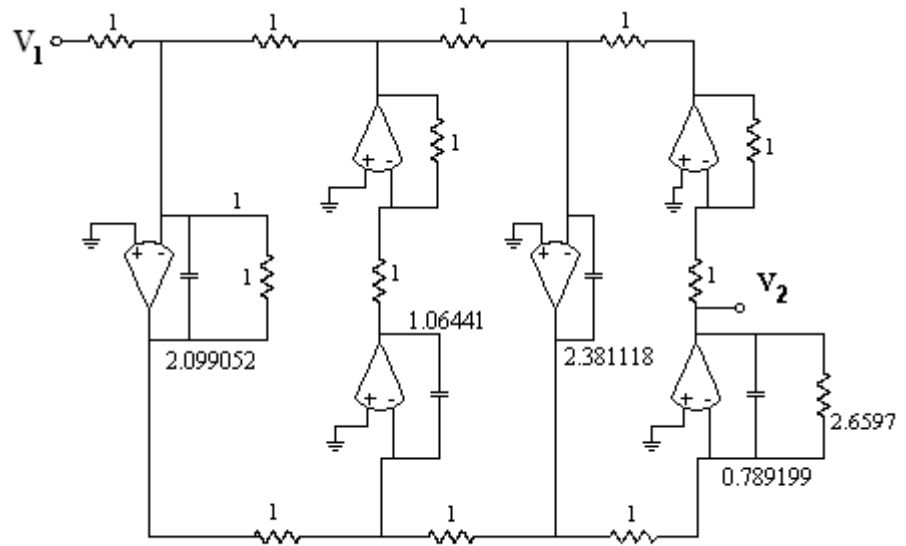

- 4.9. The circuit shown is a Sallen and Key low pass filter. Obtain the frequency response. The element values are  $C_2 = C_4 = 1 \mu F$ ,  $R_1 = R_3 = 1 K\Omega$ . The amplifier gain is  $K = 1$ . Implement the amplifier with a voltage follower using an op-amp 741.



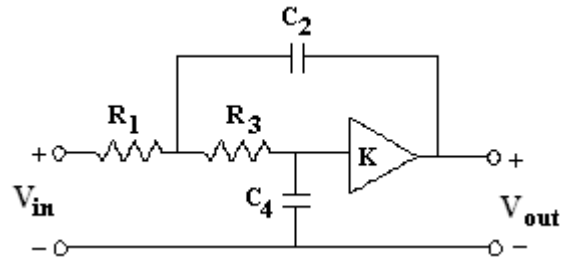

4.10. Obtain the magnitude Bode plot for the circuit shown. Identify the notch frequency.

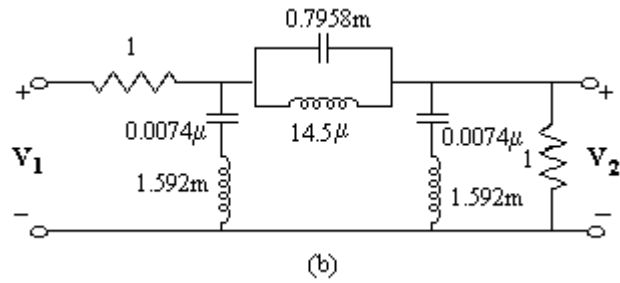



# Semiconductor Devices

## INTRODUCTION

Semiconductor devices are the main components of electronic, electric, and mechatronic systems. They can be used to develop countless tasks in telecommunication systems, industrial control of processes, entertainment systems, home appliances, satellite control, to name a few. In this chapter, we describe the way to simulate circuits using semiconductor devices such as diodes, bipolar junction transistors (BJT), MOSFETs, JFETs, and operational amplifiers. Although there are more types of semiconductor devices, the ones mentioned here are by far the most used in modern electronics. In general, with the exception of diodes, most semiconductor devices are known as active elements. On the other hand, resistors, capacitors, and inductors are known as passive devices.

Basic semiconductor devices, such as diodes and transistors, have a model associated with them. This model represents the main characteristics of the device. For example, the  $\beta$  of a BJT is one of such parameters. Some other more complex semiconductor devices are composed of diodes, transistors, and passive elements, are described in Multisim by a subcircuit. A subcircuit is the equivalent of a subroutine in any programming language. It is a set of interconnected elements that can be reused in the same circuit without the need to redraw all the elements in the circuit. Some devices that are described by subcircuits are operational amplifiers and logic devices. In this chapter, we describe how Multisim can simulate circuits with diodes and transistors and the more complex devices such as operational amplifiers and other integrated circuits such as comparator, the 555 timer, voltage references, multipliers, and active filters to mention a few. Digital integrated circuits are also composed of diodes and transistors and they are the topic of the following chapter.

## 5.1 DIODES

For the semiconductor diode the symbol is shown in Fig. 5.1. Diodes are available from Diode group in the Components toolbar that can be seen in Fig. 5.2. The dialog window to select a particular diode is shown in Fig. 5.3.

In this window, we can see that there are available different types of diodes such as zener, LED, SCR, Schottky, diode bridges, etc. When placed in the schematic circuit, diodes are indicated with the letter D.

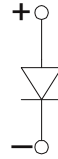

Figure 5.1: Diode symbol.



Figure 5.2: Diode group icon.

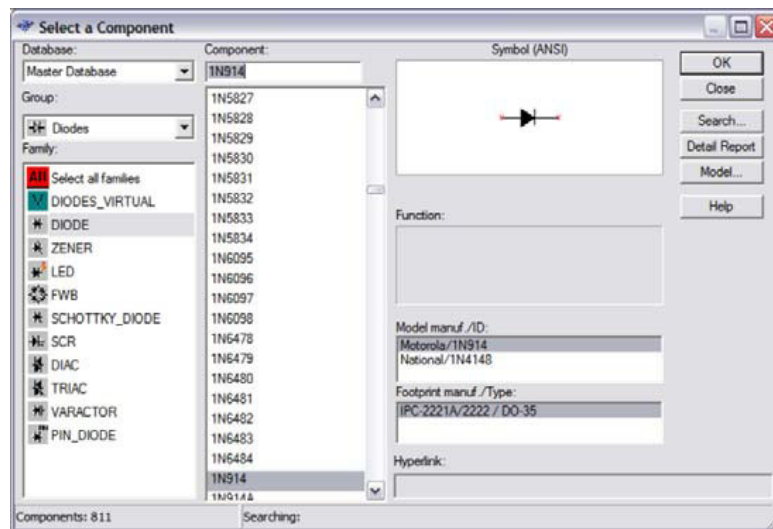

Figure 5.3: Dialog window to select the diode.

**Example 5.1 Half-wave rectifier**

Let us consider the circuit of Fig. 5.4. It is a half-wave rectifier circuit using the rectifier diode 1N4001. We perform a transient analysis on this circuit from 0 sec to 30 msec. The AC source has a 60 Hz frequency and a peak value of 10 V. Fig. 5.5 shows the input and output waveforms. We can clearly see the half wave rectifier behavior.

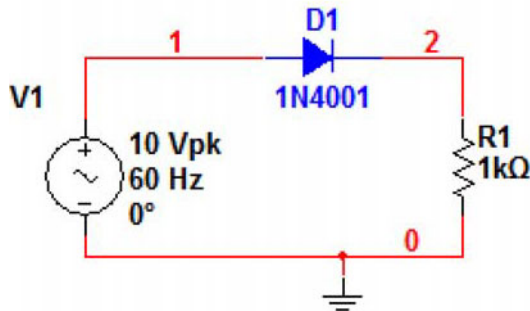

Figure 5.4: Half wave rectifier circuit.

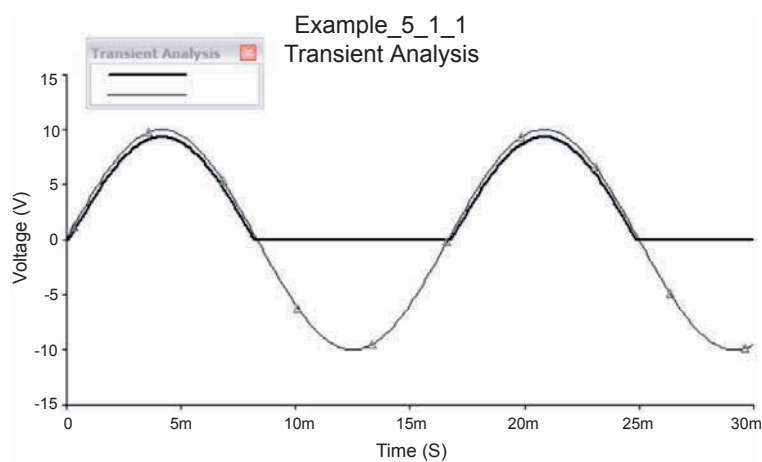

Figure 5.5: Input and output waveforms for the half wave rectifier circuit.

Now we double click on the diode symbol in the circuit to obtain the dialog window of Fig. 5.6. The Value tab is displayed in the figure. Besides the diode number, there are shown the Footprint and the function this diode realizes, in this case a rectifier diode. There are also four push buttons which are used in the definition of the diode model parameters. If we press the Edit Model button we obtain the window of Fig. 5.7 which displays the parameters of the diode model. For a description of each one of these parameters the reader is referred to any text available on semiconductors such as Ref. [1].



**Figure 5.6:** Dialog window for the diode properties.

## 5.2 TRANSISTORS

Multisim can simulate circuits with the three types of transistors. They are the Bipolar Junction Transistor (BJT), the Metal-Oxide-Semiconductor Field Effect Transistor (MOSFET), and the Junction Field Effect Transistor (JFET). In addition, Multisim also includes the Unijunction transistor (UJT), power MOS transistor, and the Darlington transistor array. The symbols for these transistors are shown in Fig. 5.8. For the PNP BJT, channel P MOSFET, and channel P JFET, the arrow is in the opposite direction. Every transistor name starts with the letter  $Q$  and it is numbered sequentially, thus the first transistor is  $Q_1$ , the second one is  $Q_2$ , and so on.

Any transistor is available by clicking on the transistor group icon in the components toolbar shown in Fig. 5.9.

## 5.3 BIPOLAR TRANSISTORS

In this section, we treat bipolar transistors only. An example is useful to see some of the characteristic parameters of BJTs.

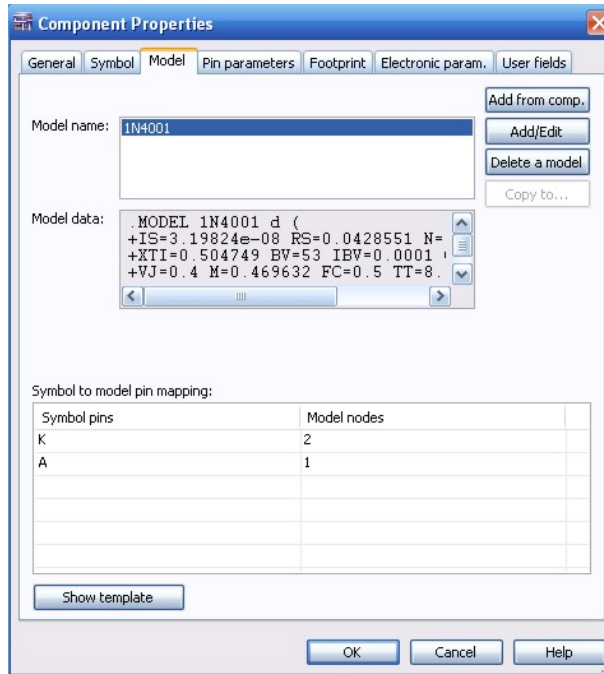

Figure 5.7: 1N4002 diode model.

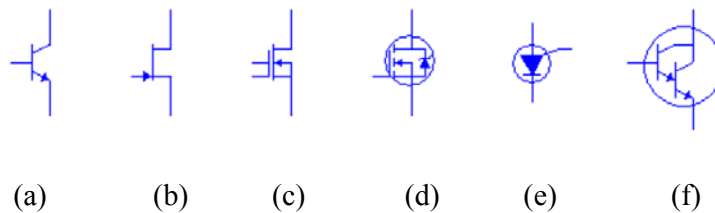

Figure 5.8: Transistor symbols in Multisim. (a) BJT npn; (b) Channel n JFET; (c) Channel n MOSFET; (d) Power MOSFET; (e) Unijunction transistor; (f) Darlington pair.

### Example 5.2 Characteristic curves of NPN BJT.

The circuit of Fig. 5.10 is useful to plot the characteristic curves of a BJT. Basically, a BJT is composed by two back-to-back diodes, one of them, the base emitter-diode, is forward biased and the other one, the base-collector diode, is reverse biased. In our circuit, the voltage source V1 forward biases the base-emitter diode. The voltage drop across the base emitter diode is approximately 0.7 V



**Figure 5.9:** Transistor group icon.

for silicon transistors and 0.2 V for germanium ones. In order to plot the characteristic curves, we use the I-V plotter from the Instruments toolbar. This instrument plots the collector current vs. collector-emitter voltage with base current as a parameter.

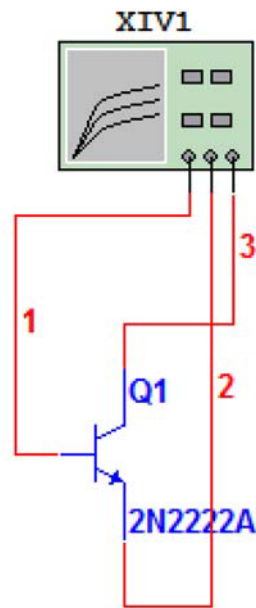
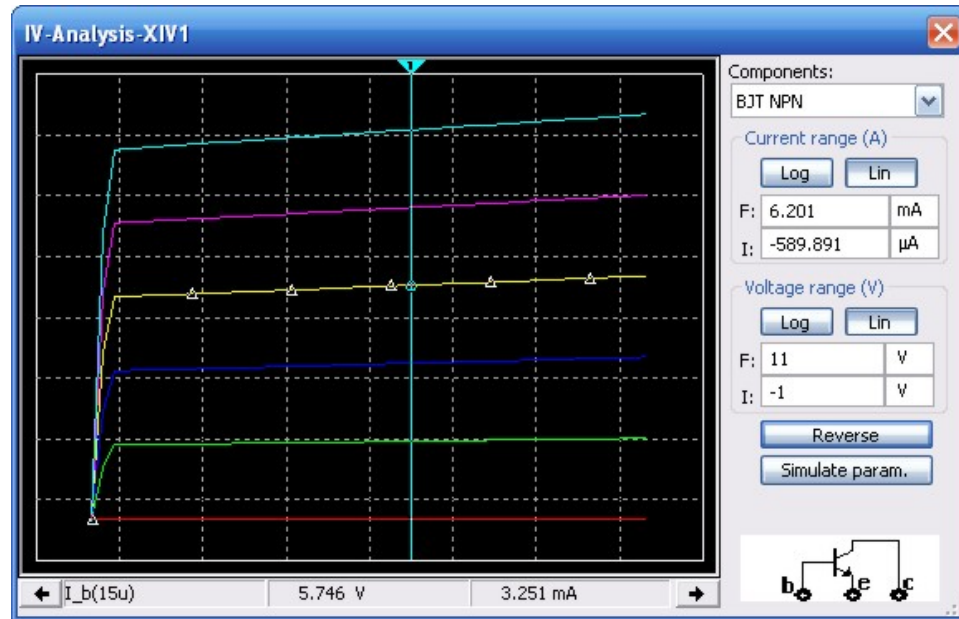

**Figure 5.10:** Circuit to obtain BJT characteristic curves.

To obtain the characteristic curves we only have to use the Run icon and open the I-V Analysis instrument to observe the curves. We show them at the window of Fig. 5.11.

Fig. 5.11 shows the cursor positioned at the position of  $V_{ce} = 5.746$  V, a collector current  $I_c = 3.251$  mA, and a base current  $I_b = 15$   $\mu$ A, which correspond to the fourth curve. If we press the





**Figure 5.11:** I-V characteristic curves.

Sim\_Param button we open the window of Fig. 5.12 where we specify parameters for the collector-emitter voltage  $V_{ce}$  and the base current  $I_b$ .

### Example 5.3 Differential amplifier.

A differential amplifier is a two transistor amplifier with two inputs. The differential amplifier output voltage is the voltage difference of the two input voltages amplified by the gain of the differential amplifier. For our example let us consider the circuit of Fig. 5.13. The input voltages  $V_1$  and  $V_2$  are two sine waves with very different frequencies, 50 Hz and 5 KHz, and peak to peak voltages 0.2 V and 0.1 V, respectively. The transistors used are 2N2222. We perform a transient analysis from 0 to 1 msec. The input waveforms are shown in Fig. 5.14. The output waveform is shown in Fig. 5.15 and we see it is the difference of the two input signals amplified by a gain of -30.

We observe that the input waveforms cannot be clearly appreciated. We now plot them in a graph with two plots using the Postprocessor. To do this we open the postprocessor window by selecting from the main menu Simulate→Postprocessor. The Postprocessor window is shown in Fig. 5.16 and we see the variables available from the simulation  $V(\text{vin1})$  and  $V(\text{vin2})$ . We select these variables and press the Copy variable to expression as in Fig. 5.17.

We now select the Graph tab. This tab, seen in Fig. 5.18, has two spaces with spreadsheets and two spaces. A new plot is created by clicking on the Add button to the right of the Pages

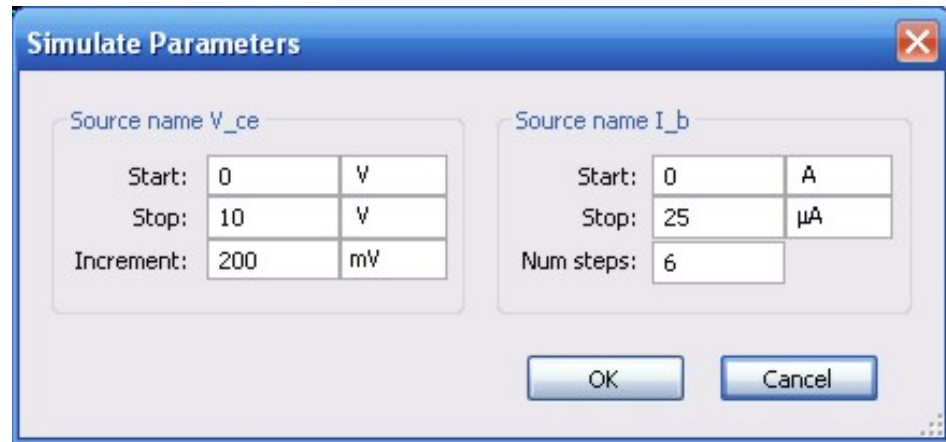

Figure 5.12: Dialog window to choose variables for the plot.

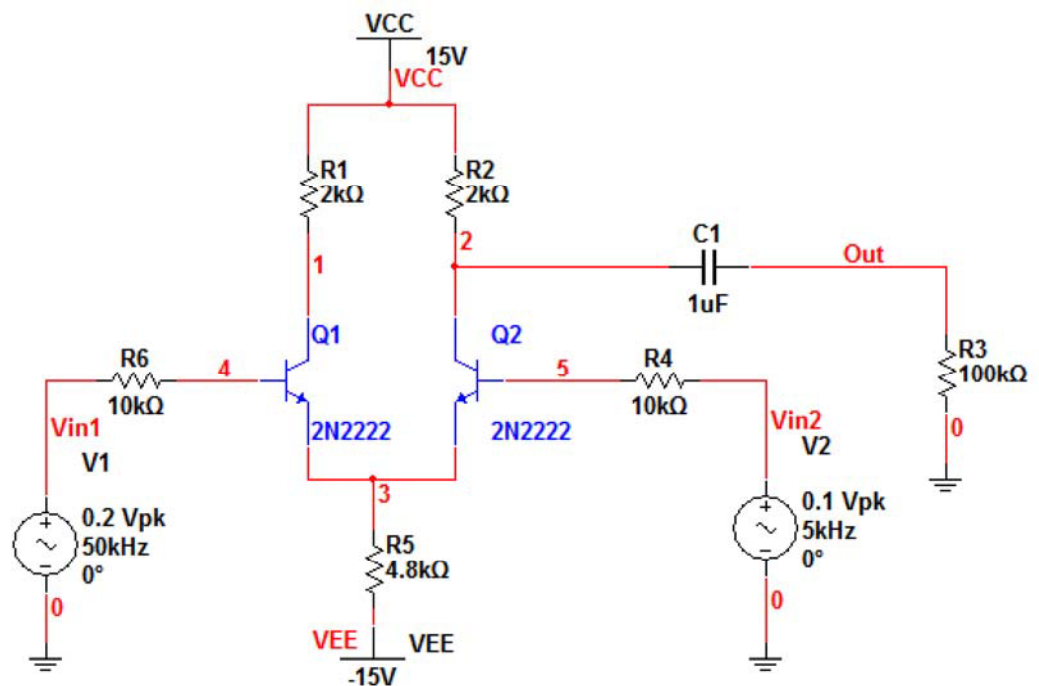

Figure 5.13: Differential amplifier.

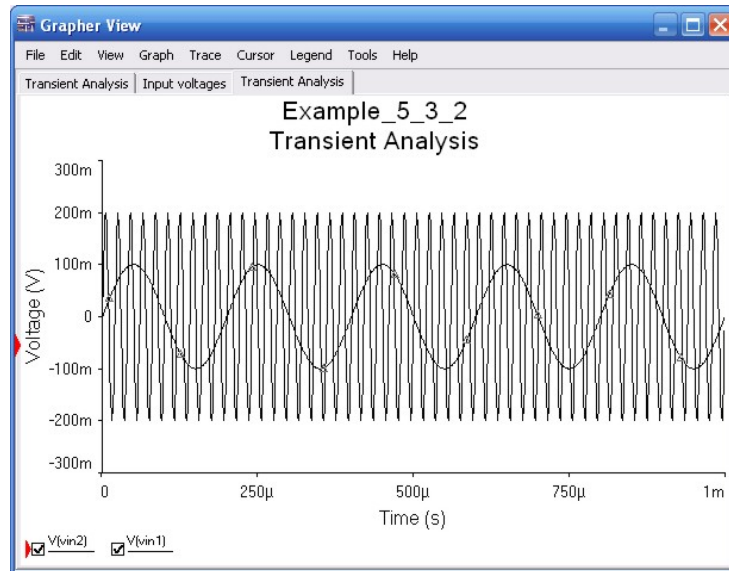

Figure 5.14: Input waveforms.

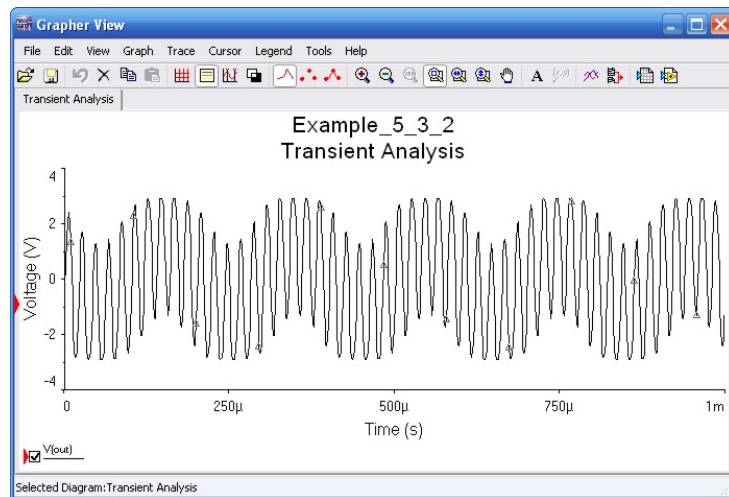

Figure 5.15: Output waveform.

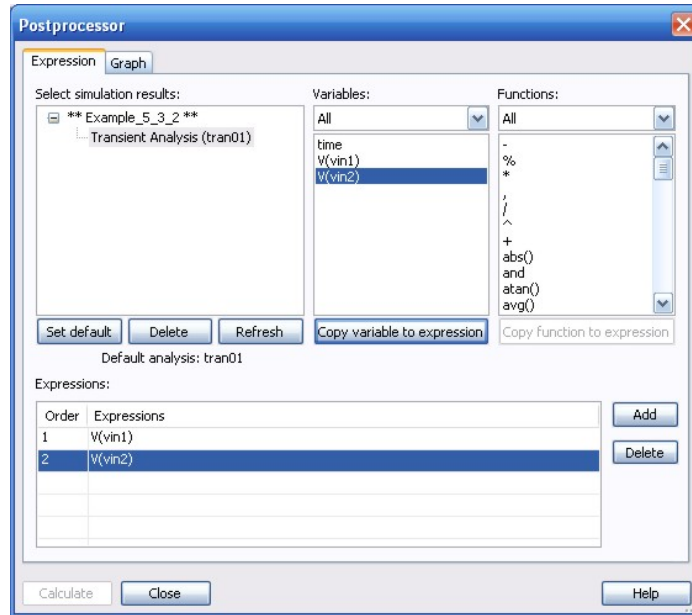

Figure 5.16: Postprocessor window with Expressions tab selected.

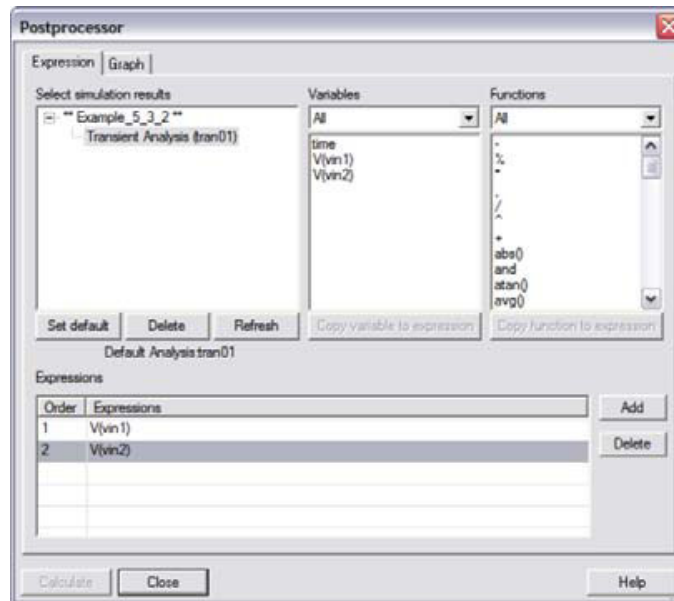
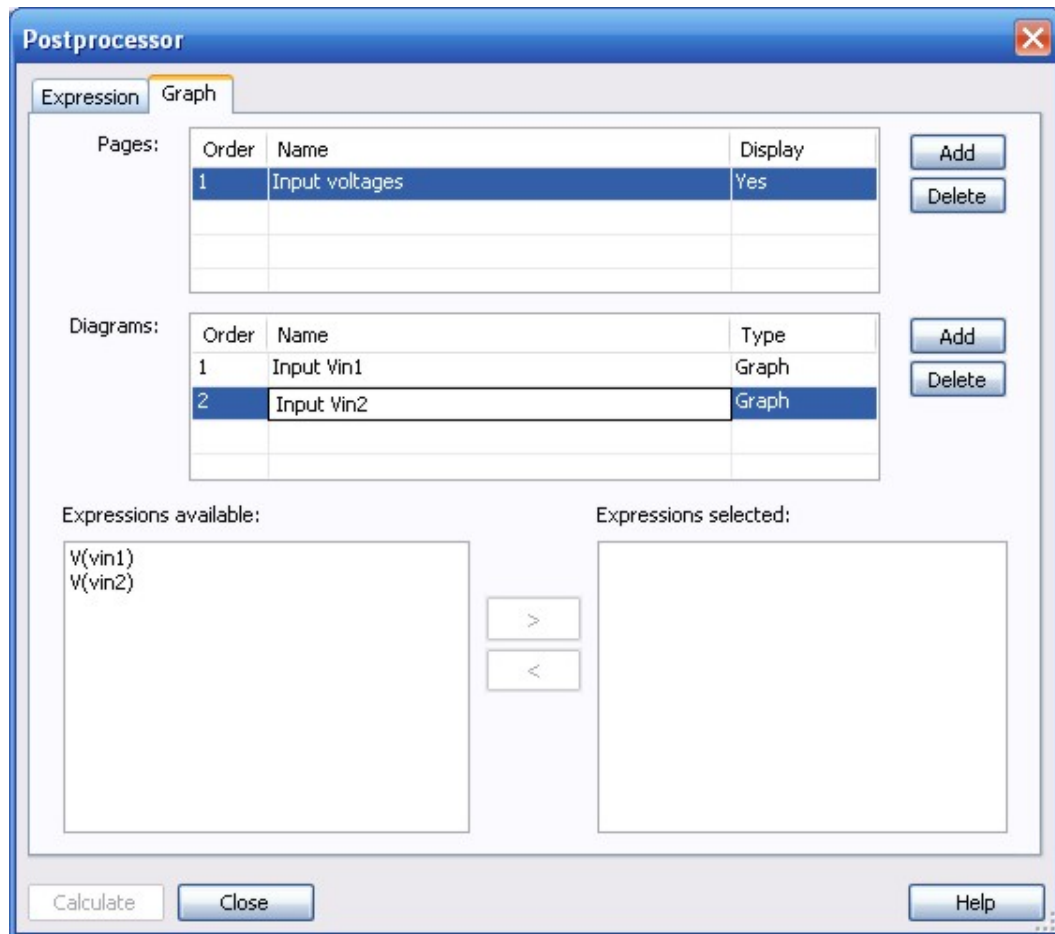

Figure 5.17: Postprocessor window with variables to plot.



**Figure 5.18:** Procedure to add a variable to the first set of axis Input Vin1.

spreadsheet. We write the name of the plot Input voltages. Now we click twice on the Add button in the Diagrams spreadsheet. Each click creates a new set of axes in the page Input voltages. In the first set of axes we plot  $V(\text{vin1})$  and in the second set we plot  $V(\text{vin2})$ . Now in the spreadsheet for Diagrams we select the one named Input Vin1 and in the Expressions available space add  $V(\text{vin2})$  to the Expression selected space as shown in Fig. 5.19. We repeat for the other variable  $V(\text{vin2})$  and add it to the second set of axis. After finishing we press the Calculate button and then we obtain the plots of Fig. 5.20.

#### Example 5.4 Common emitter amplifier.

The circuit of Fig. 5.23 is a common emitter amplifier. If we look carefully at this circuit it lacks an emitter resistor. The purpose of this emitter is to make the amplifier insensitive to changes in the transistor  $\beta$  [10].

We make a transient analysis on this circuit with a final time of 2 msec. The variables selected for display are Vin1 and Vin2. We run the analysis with the Run button and observe the input and output waveforms in the oscilloscope window of Fig. 5.22. Observe the scales for the base-time and the voltage for both channels. Make sure the AC button beneath for both channels are pressed. There we see that the input and output peak to peak voltages are 19.981 mV and 2.299 V, respectively. The midband gain is then

$$\text{Gain} = -\frac{2.299}{0.19981} = -115.06 .$$

Now, we make a double click on the transistor. This opens the window of Fig. 5.23 and there we press the Edit Model button. Then, the model for the 2N2222A bipolar transistor is open showing the model as shown in Fig. 5.24. This model displays the parameters of the BJT repeated here from this last figure:

```
.MODEL Q2N2222A NPN IS =3.0611E-14 NF =1.00124 BF =220 IKF=0.52
+ VAF=104 ISE=7.5E-15 NE =1.41 NR =1.005 BR =4 IKR=0.24
+ VAR=28 ISC=1.06525E-11 NC =1.3728 RB =0.13 RE =0.22
+ RC =0.12 CJC=9.12E-12 MJC=0.3508 VJC=0.4089
+ CJE=27.01E-12 TF =0.325E-9 TR =100E-9 .
```

For example, the parameter  $\beta$  is given by  $\text{BF} = 220$  and the ohmic resistors associated with base, emitter, and collector are 0.13, 0.22, and 0.12, respectively. The companion book *Advanced Circuit Simulation using Multisim Workbench* shows how to edit the models for semiconductor devices.

## 5.4 JUNCTION FIELD EFFECT TRANSISTORS-JFET'S

Junction field effect transistors are found in the Transistors group and their models start with the letter J. JFETs are built with two reverse biased pn junctions. They are three terminal devices. Their

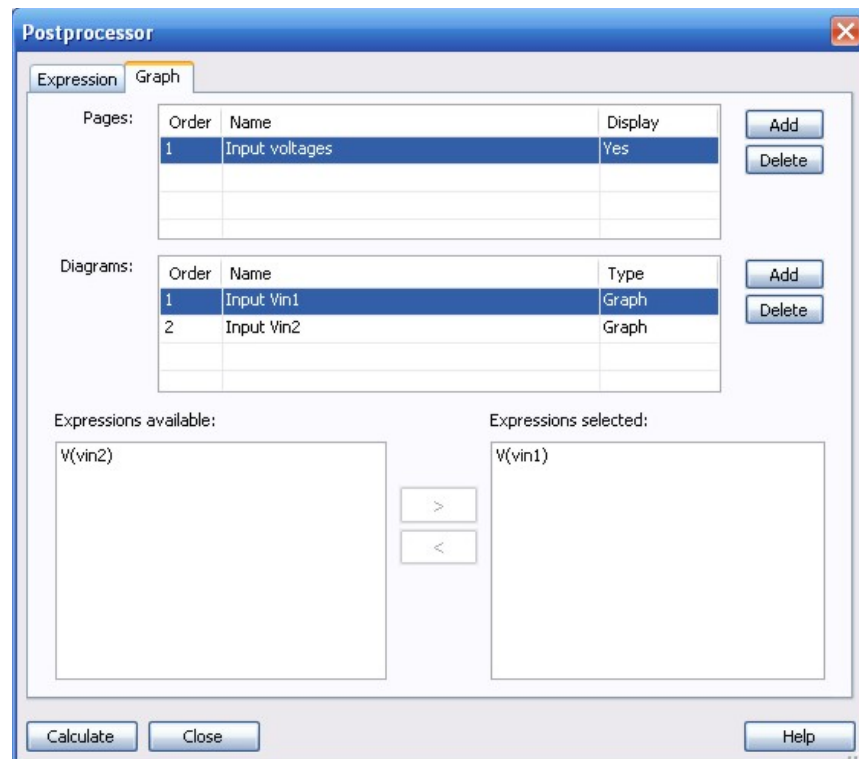

**Figure 5.19:** Postprocessor window with Graph tab selected. (a) The variables for upper plot at Expression space.

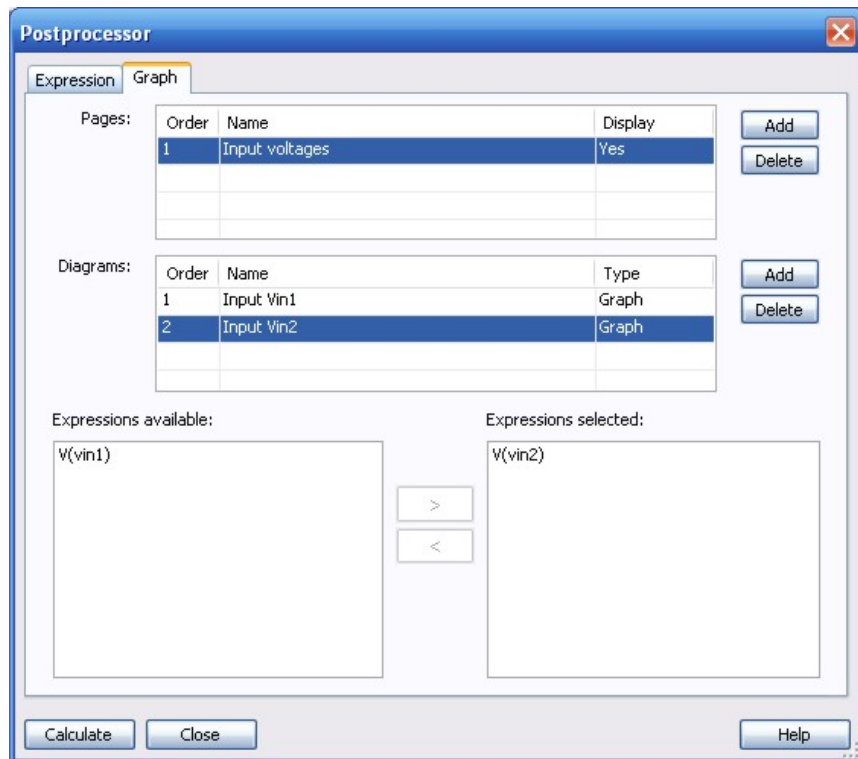

**Figure 5.19:** Postprocessor window with Graph tab selected. (b) Variable for upper plot at Expressions space.



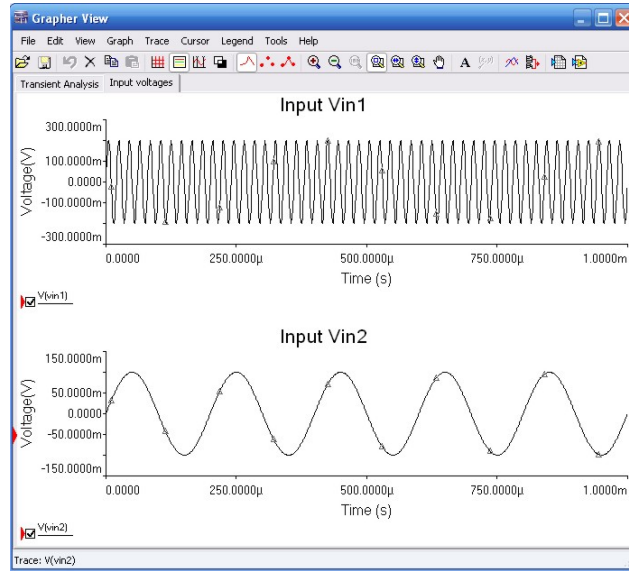

Figure 5.20: Plots of output variables in the Postprocessor window.

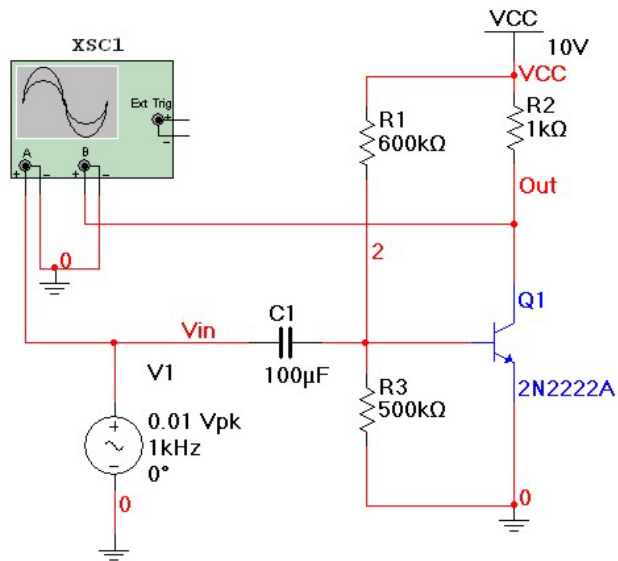

Figure 5.21: Common emitter amplifier without emitter resistor.

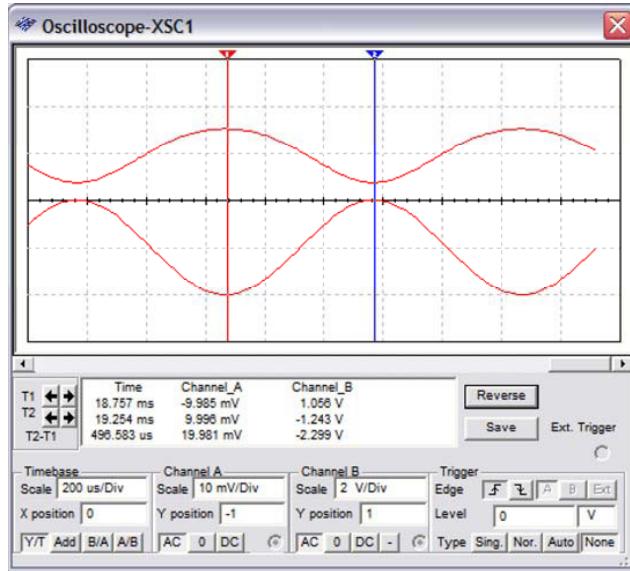

Figure 5.22: Oscilloscope window displaying input and output waveforms.

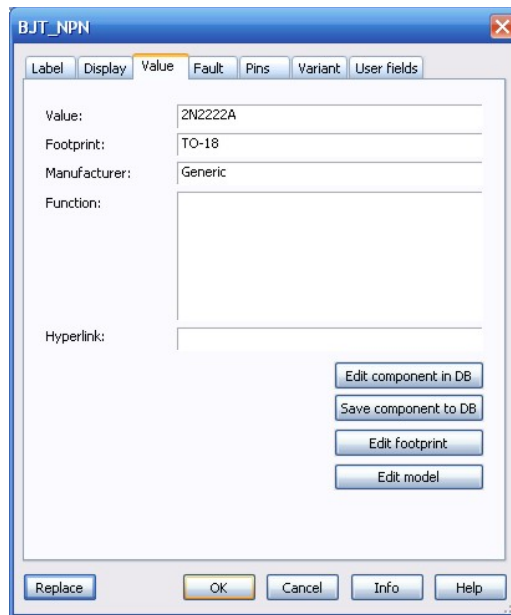
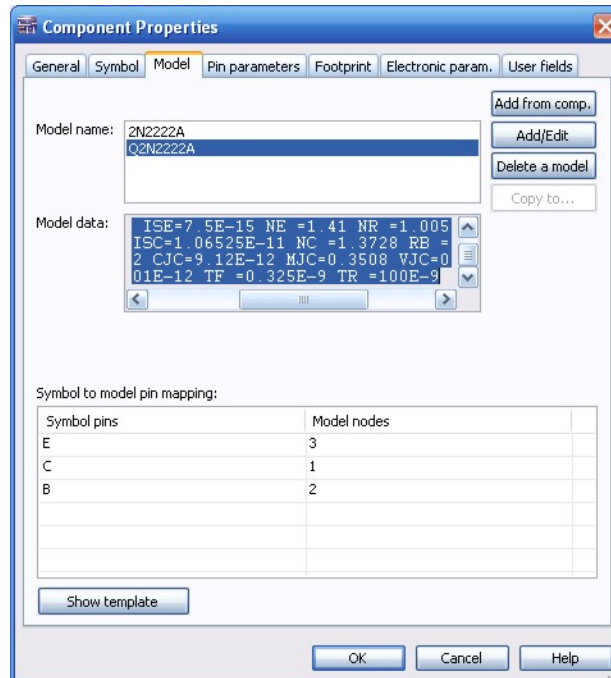

Figure 5.23: Window with data for transistor 2N2222A.



**Figure 5.24:** Model for the BJT 2N2222A.

terminals are called drain, source, and gate. Their characteristic curves can be plotted with a nested DC sweep analysis. Let us consider the circuit of Fig. 5.25, VDD is Source 1 and VGG is source 2 in the DC sweep. From the main menu select Simulate→Analyses→DC Sweep we obtain the dialog window of Fig. 5.26. We enter the data as shown there for the sources.

We now select the Output tab to get the window of Fig. 5.27. The output variable we wish to plot is the drain current  $I_D$  which is not available in the output variables to plot. Instead, it is available the current through VDD as  $I(vdd)$ . The desired current is given by  $I_D = -I(vdd)$ . Thus, we have to plot this current. To do this we click on the Add Expression button to obtain the window of Fig. 5.28. There we can form the desired output variable in the Expression space. We write there  $-I(vdd)$ , press the OK button and then when we return to the previous window we click on the Simulate button to obtain the curves shown in Fig. 5.29. These are the characteristic curves for a JFET. Note that the slope of the curves is less than that obtained for the BJT in Fig. 5.16.

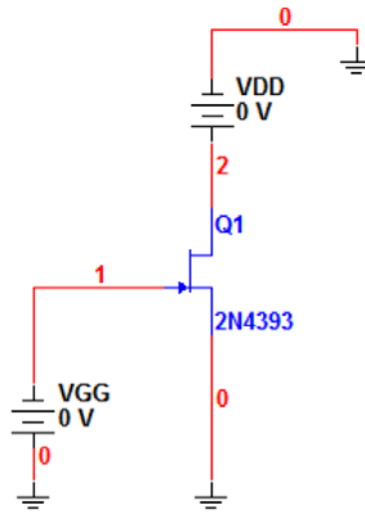

**Figure 5.25:** Circuit to obtain the characteristic curves of a JFET.

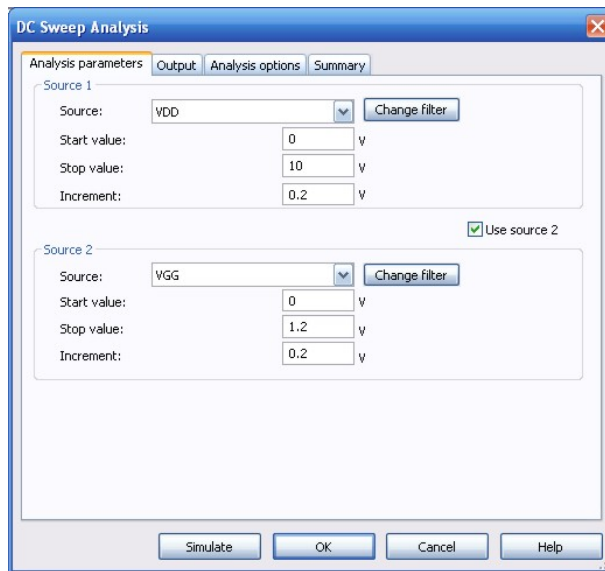

**Figure 5.26:** Dialog window to specify the sources in a DC sweep.

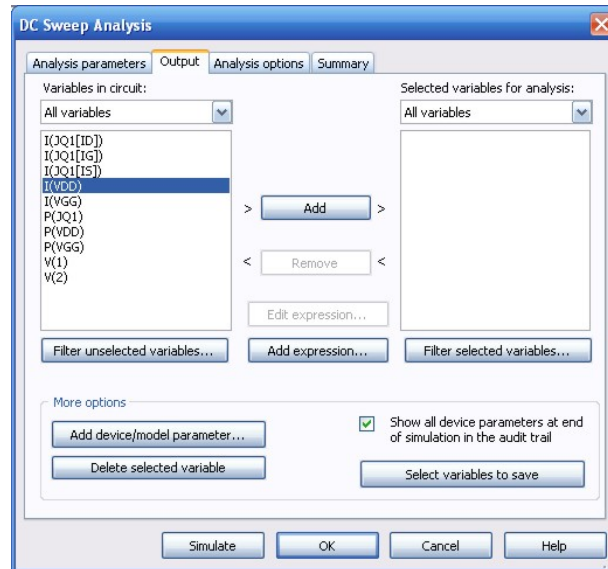

Figure 5.27: Output variables available for plotting.

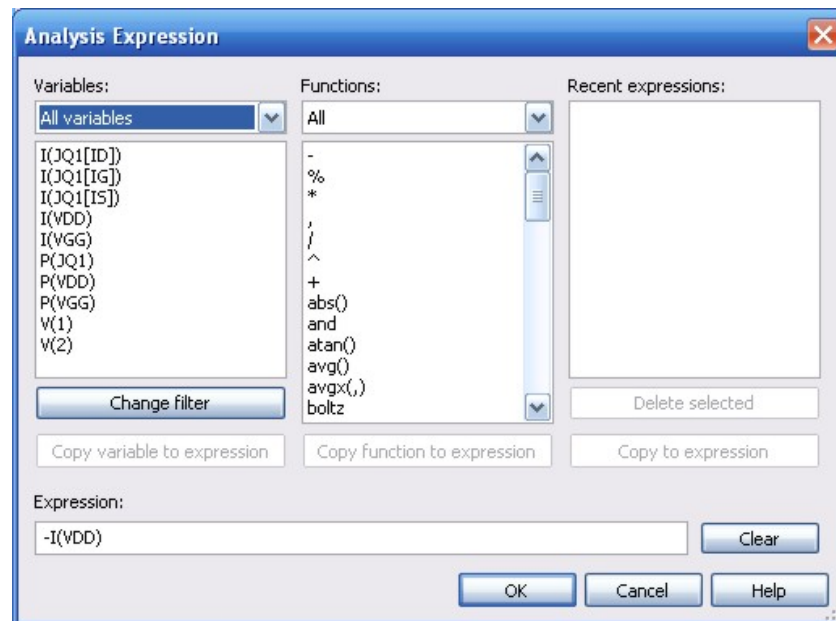

Figure 5.28: Writing the expression for the drain current.

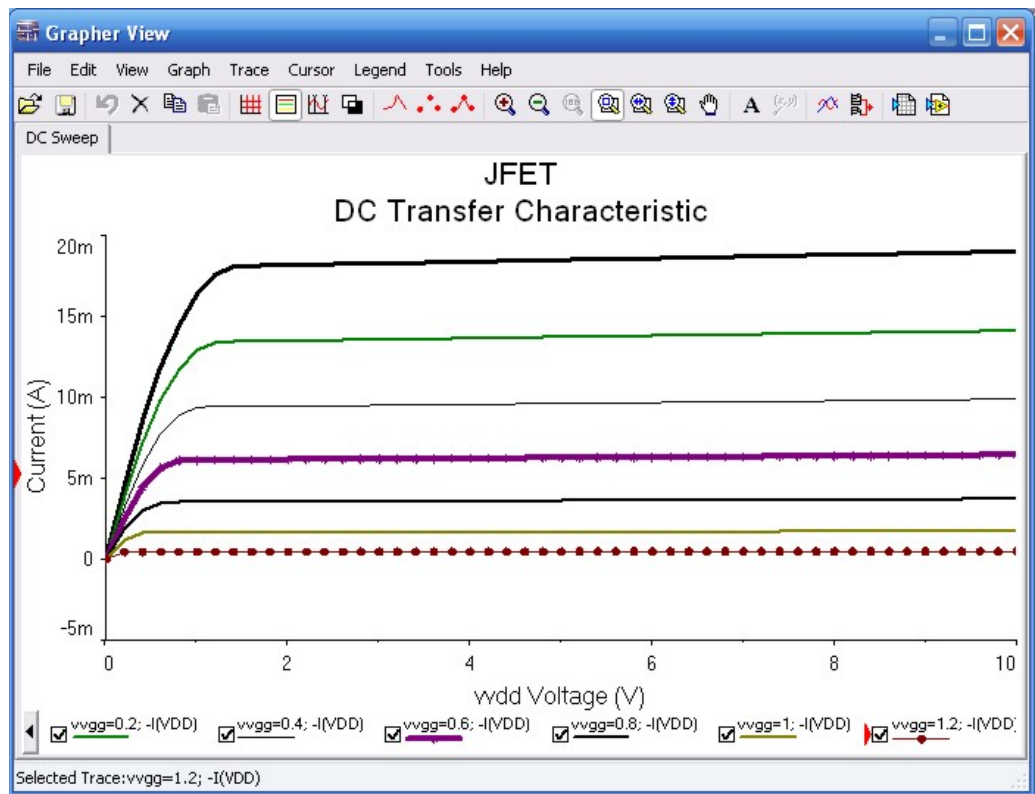
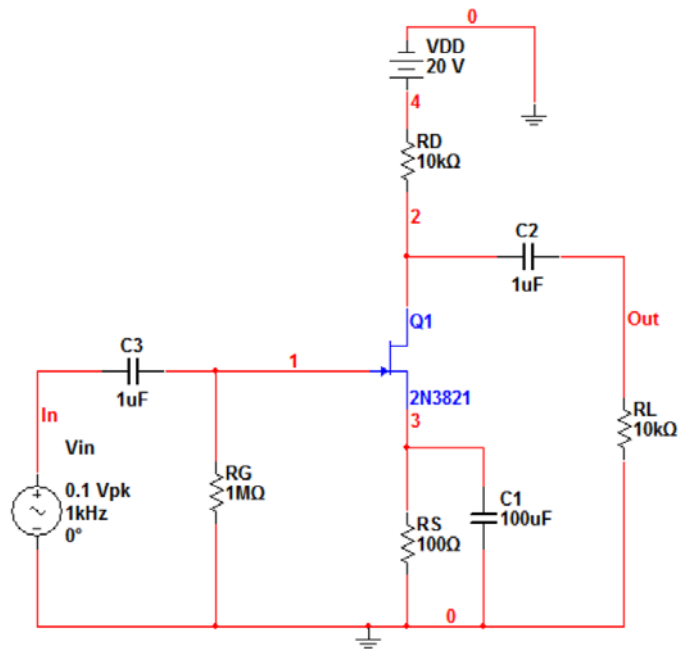

Figure 5.29: Characteristic curves for a JFET.

**Example 5.5 JFET inverter amplifier.**

One of the most common applications of JFETs is in amplifiers. The circuit in Fig. 5.30 shows a common source amplifier. The JFET is biased by a power supply VDD and resistors RD, RS, and RG. The input signal is a 0.1 Vpp with 1 KHz. The output voltage appears across RL. First, we make a transient analysis from 0–5 msec. The input and output waveforms are shown in Fig. 5.31. Measuring the amplitude of the signals we can see that the voltage gain is -11.6. Then we make an AC analysis and the frequency response magnitude is plotted in Fig. 5.32. We see that from about 40 Hz up to 20 MHz the gain is flat at 11.6.



**Figure 5.30:** JFET common source amplifier.

## 5.5 METAL OXIDE SEMICONDUCTOR FIELD EFFECT TRANSISTORS-MOSFET'S

Metal oxide semiconductor (MOS) field effect transistors have the letter M for their Multisim description. They have also three terminals named Drain, Source and Gate. They have properties similar to those of the JFETs but their construction is quite different. MOSFETs are also known as IGFETs which is an acronym for Insulated Gate Field Effect Transistor. MOSFETs are used in

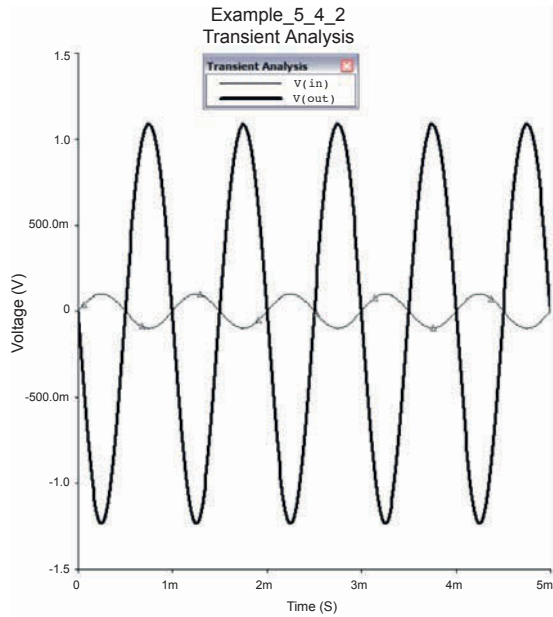

Figure 5.31: Input and output waveforms.

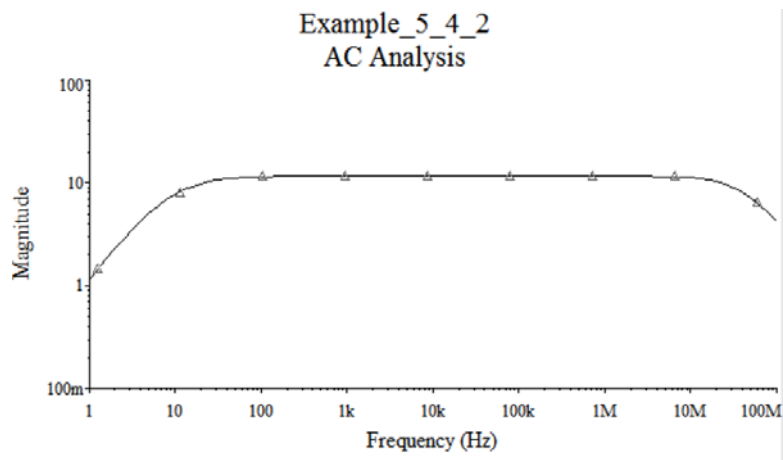

Figure 5.32: Frequency response magnitude.



every modern microprocessor such as Intel's Itanium and Xeon and the hafnium-based Intel 45nm high-k Penryn, or AMD's Opteron and Phenom. A very important characteristic of a MOSFET is its low power consumption and thus they are very useful in portable applications such as cellular phones, PDAs, and laptop computers, to name a few applications.

There exist a large number of MOSFET models for simulation. They are referred to as LEVELs. The most common levels used are level 1 and level 3 although most complex models are more accurate for low voltage and low channel length transistors. The following list explains some characteristics of each model:

Model 1: (**LEVEL** =1) Schichman-Hodges model. This is the basic model and its equations are similar to those of a JFET [2].

Model 2: (**LEVEL** =2) This is an analytic model based in the geometry of the device [3].

Model 3: (**LEVEL** =3) This is a semiempirical model and it is based in the transistor model for short channel length. It is widely used [3].

Model 4: (**LEVEL**=4) BSIM model. This model is characterized by some manufacturing process [4].

Model 5: (**LEVEL** =5) EKV model version 2.5. It is mainly used in submicrometric processes [7].

Model 5: (**LEVEL** =5) BSIM3 model version 2.0. It is used in physical models where there is a strong approach to submicron processes [5].

Model 7: (**LEVEL** =7) BSIM3 model version 3.1. This is an improved version of model 6 [6].

Reference [8, 9] provides a comprehensive treatment of transistor models.

MOSFETs available in Multisim libraries already have a model specified and it is not needed to do it by the user.

#### Example 5.6 MOSFET characteristic curves.

The circuit of Fig. 5.33 shows a circuit which is suitable to plot the characteristic curves. We run a DC Sweep analysis with VDD as source 1 and VGG as source 2. The DC Sweep Analysis window is shown in Fig. 5.34. We plot  $-I(\text{vdd})$  which is the current  $I_D$  (see Example 5.5 for the details to define  $-I(\text{vdd})$ ). The window to specify the output variables is shown in Fig. 5.35. After clicking on the Simulate button we obtain the characteristic curves of Fig. 5.36. We note that the curve slope at the saturation region is almost zero.

#### Example 5.7 MOSFET amplifier.

Let us consider the circuit of Fig. 5.37 which is a common source inverting amplifier. We wish to investigate the time domain response. We run then a transient analysis from 0–2 msec to

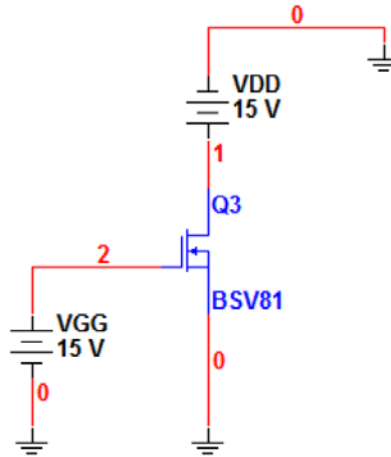

Figure 5.33: Circuit to plot characteristic curves.

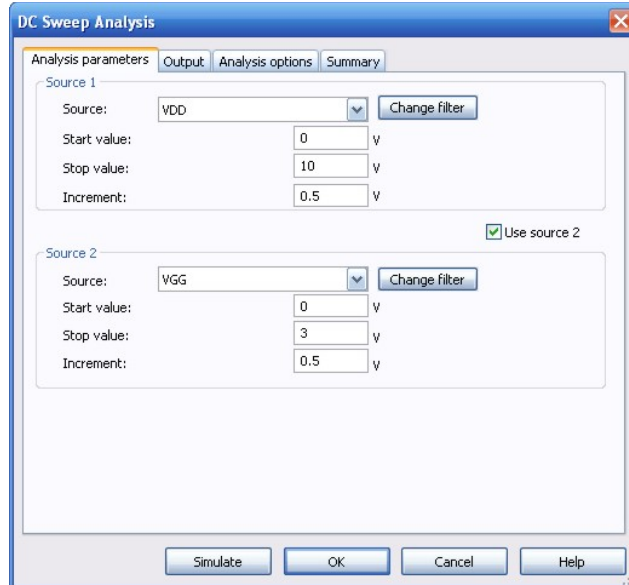

Figure 5.34: Dialog window for the DC sweep analysis.

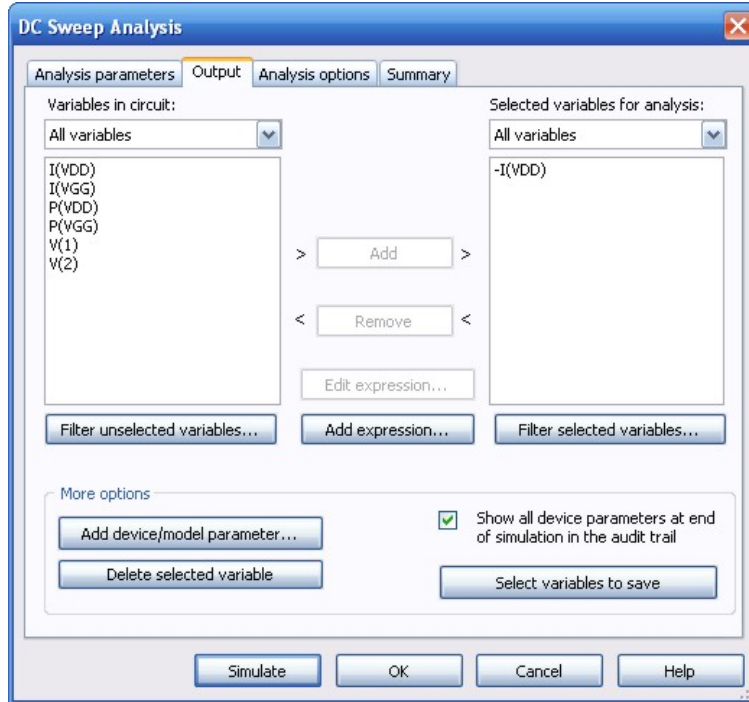

Figure 5.35: Specification of the output variable.

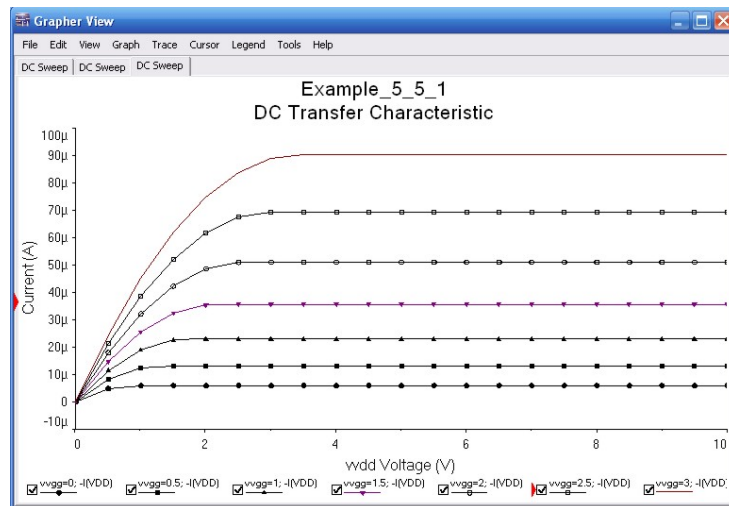
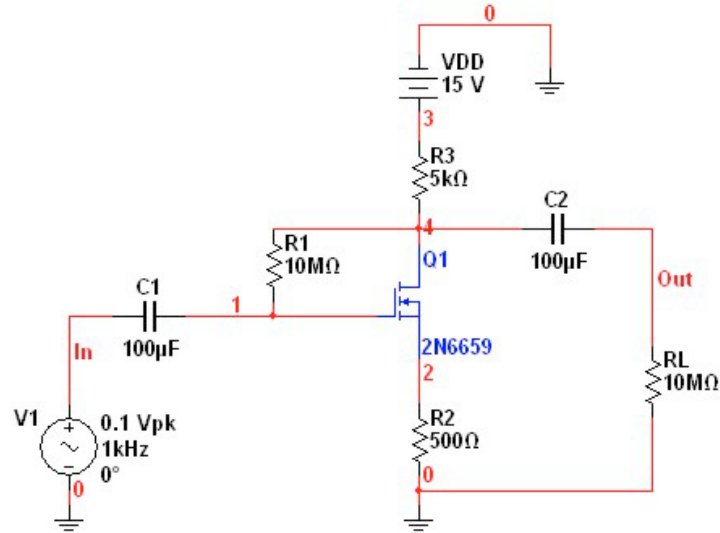

Figure 5.36: Characteristic curves of the MOSFET BSV81.



**Figure 5.37:** MOSFET inverting amplifier.

observe two cycles in the signals. The input and output signals are shown in Fig. 5.38. By measuring the amplitude of both signals we can see that the voltage gain is

$$Gain = -\frac{0.941}{.099} = -9.5 .$$

The minus sign is due to the fact that both signals are out of phase by  $180^\circ$  and thus, it is an inverting amplifier.

## 5.6 ADDITIONAL EXAMPLES

In this section we present some additional examples of circuits using transistors and diode connected transistors. For the details of the design the reader can consult some of the many books available on electronic circuit design such as Ref. [1].

### Example 5.8 NMOS logic gate inverter.

The circuit of Fig. 5.39 is a logic gate realizing the inverter function. It is formed by two N channel MOS transistors. Its operation is as follows: when the input voltage  $V_{in}$  is equal to zero (logic 0), or below a certain threshold produces an output voltage close to 6 V (logic 1). On the other hand, when the input voltage is 6 volts (logic 1), or above a certain threshold, the output is 0 V (logic 0).

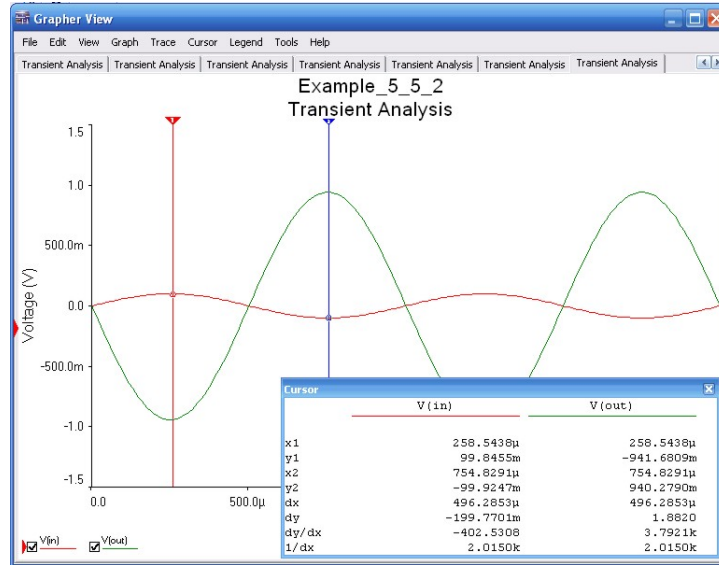

Figure 5.38: Input and output waveforms.

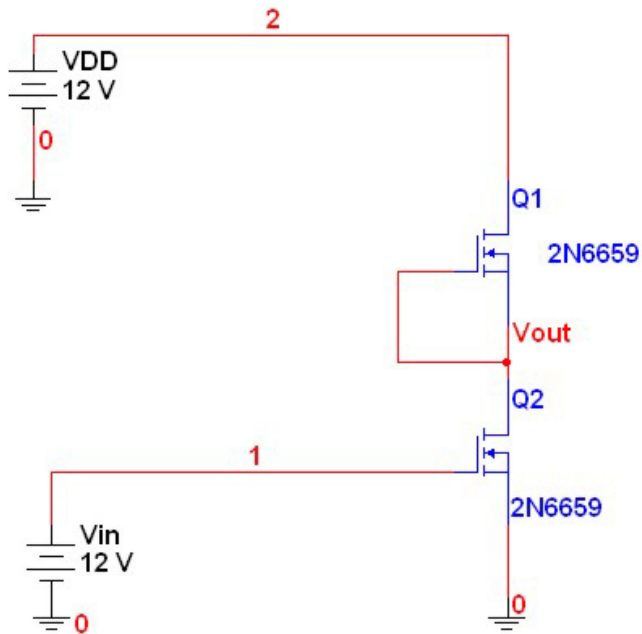
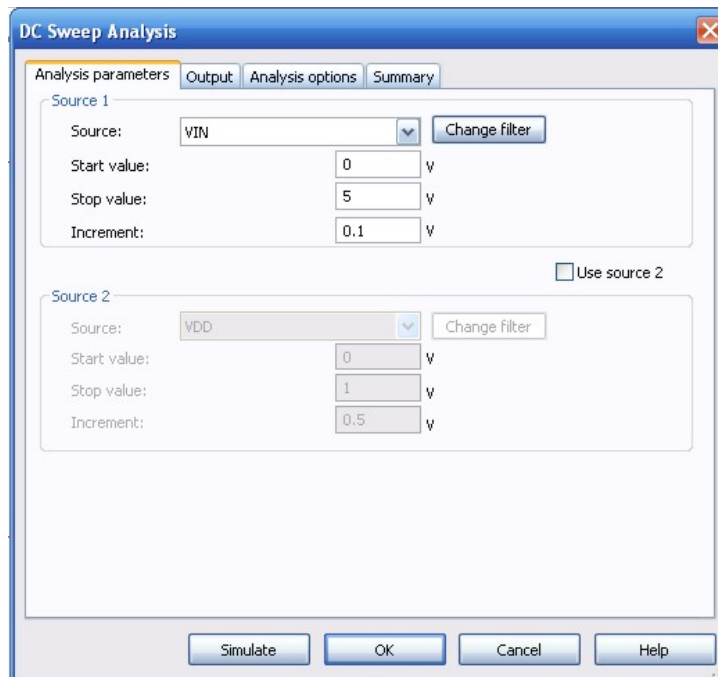

Figure 5.39: NMOS inverter logic gate.

We run a DC sweep analysis. Source 1 is  $V_{in}$  and we do not need to specify source 2. The dialog window for the DC sweep analysis is shown in Fig. 5.40. The variables to plot are  $V_{in}$  and  $V_{out}$  as seen in Fig. 5.41. After clicking on the Simulate button we obtain the plot of Fig. 5.42. There we see that when the input signal is below 2.5 V the output signal is logic 1, whereas when  $V_{in}$  is above 2.5 (logic 1) the output signal is a logic 0.



**Figure 5.40:** Dialog window to specify the parameters of the DC sweep analysis.

### Example 5.9 Bipolar operational amplifier.

An operational amplifier such as the  $\mu A741$  is formed by a differential pair and a high gain stage. The circuit of Fig. 5.43 is a basic operational amplifier. Transistors  $Q_1$  and  $Q_2$  form the differential pair and transistor  $Q_3$  is the high gain stage. Transistors  $Q_4$ ,  $Q_5$ , and  $Q_6$  form a current source. Transistors  $Q_5$  and  $Q_8$  are connected to function as diodes. We make an AC analysis to investigate the frequency response. The AC analysis parameters are shown in Fig. 5.44. The output voltage is plotted in dB. The frequency response is shown in Fig. 5.45. We use the cursors to see that the 0 dB (unity gain) frequency is 3.057 MHz. DC gain is 18.7 dB.

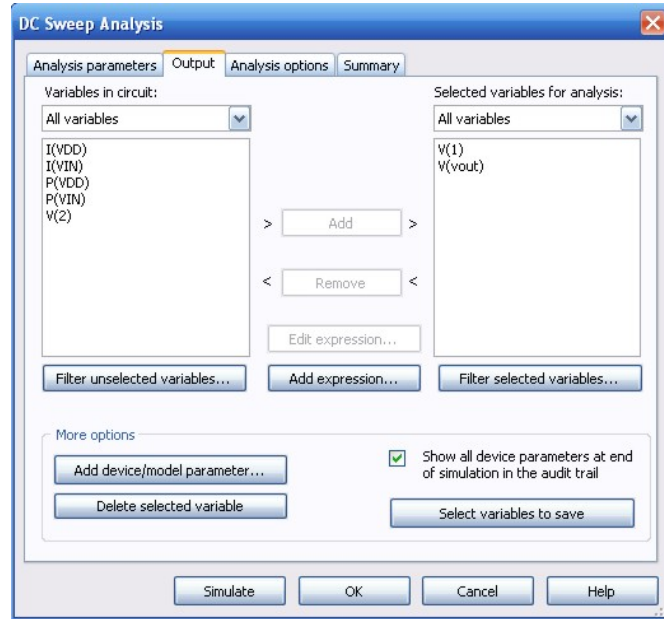

Figure 5.41: Variables to plot.

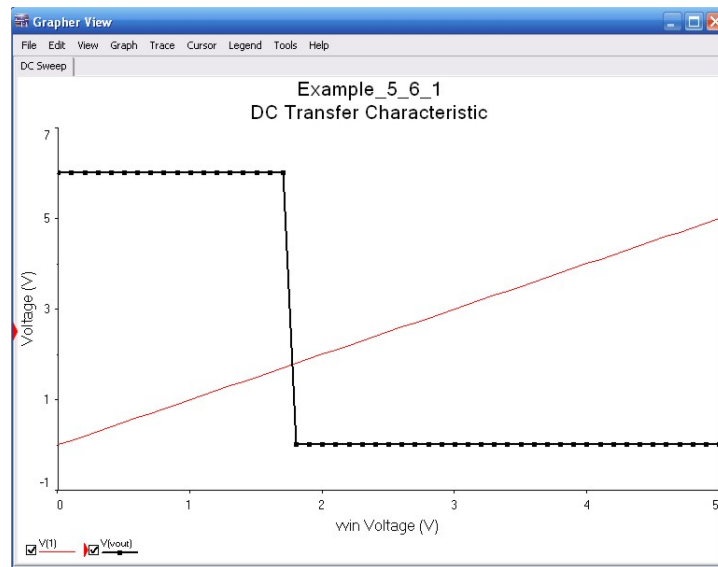

Figure 5.42: Input and output signal for the NMOS inverter gate.

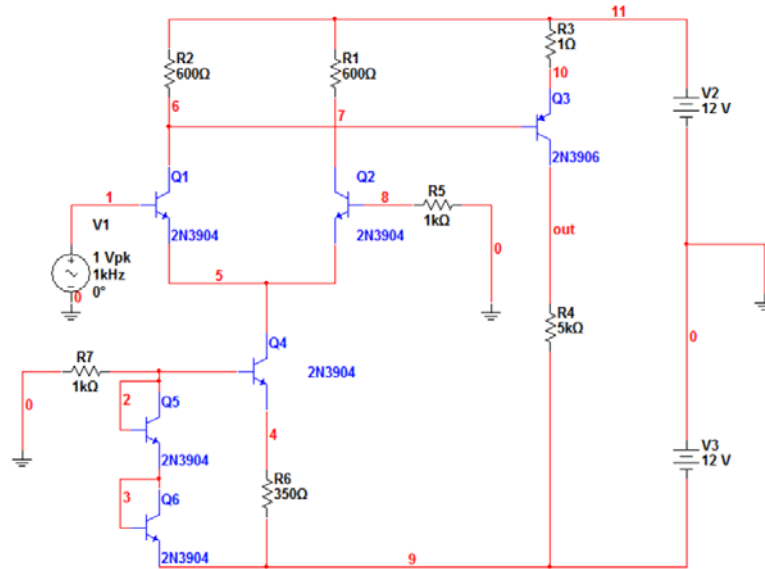

Figure 5.43: Bipolar operational amplifier.

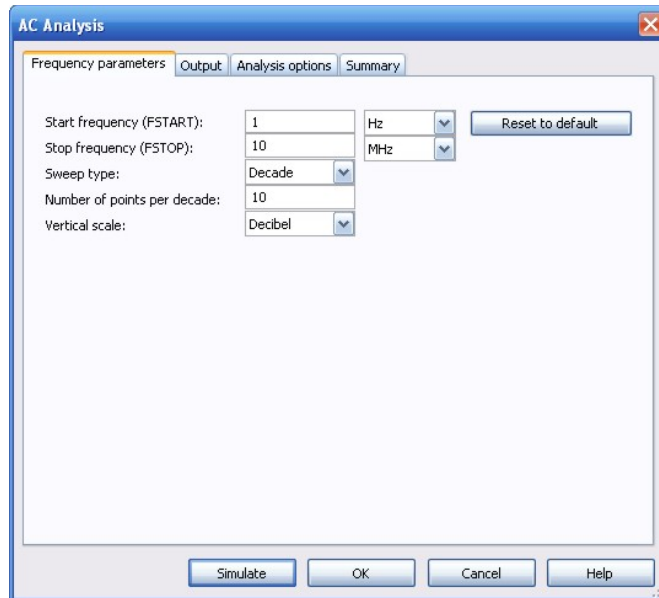
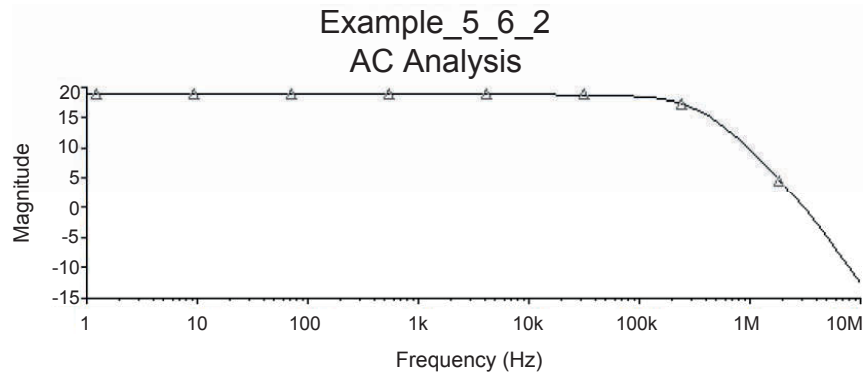

Figure 5.44: Dialog window for the AC analysis.





**Figure 5.45:** Frequency response of the bipolar operational amplifier.

#### Example 5.10 TTL Inverter.

The circuit of Fig. 5.46 is a TTL inverter gate. It is composed of bipolar transistors. The output changes from 1 to 0 when the input changes from 0 to 1. This change occurs when the input passes the threshold level for the gate. This gate uses BJT 2N3904. Note that transistors Q5, Q6, and Q7 are diode connected.

The input signal is a square wave with a period of 100 msec and a 50% duty cycle. We run a transient analysis from 0–0.4 sec (see Fig. 5.47). The input and output waveforms are displayed in Fig. 5.48.

In Fig. 5.48 the waveforms are not fully appreciated. Thus, we run now the Postprocessor to plot them in different sets of axes. From the main menu select Simulate→Postprocessor which opens the main Postprocessor window of Fig. 5.49. There we select the Expression tab and select the output variables V(in) and V(out), and then press the button Copy variable expression. Then, in the Graph window we create a page called Input/Output signals and two plots called Input signal and Output signal. In the Input signal we plot V(in) and in the Output signal V(out). We press the Calculate button and obtain the plots of Fig. 5.51 which are better than the ones previously obtained in Fig. 5.48.

## 5.7 CONCLUSIONS

In this chapter, we have covered circuits using semiconductor devices. We also show that semiconductor devices are represented by models. More complex electronic devices are composed by diodes and transistor, besides resistors and capacitors, and are the backbone of powerful integrated circuit such as microprocessors, digital signal processors, FPGAs, operational amplifiers and many other integrated circuits.

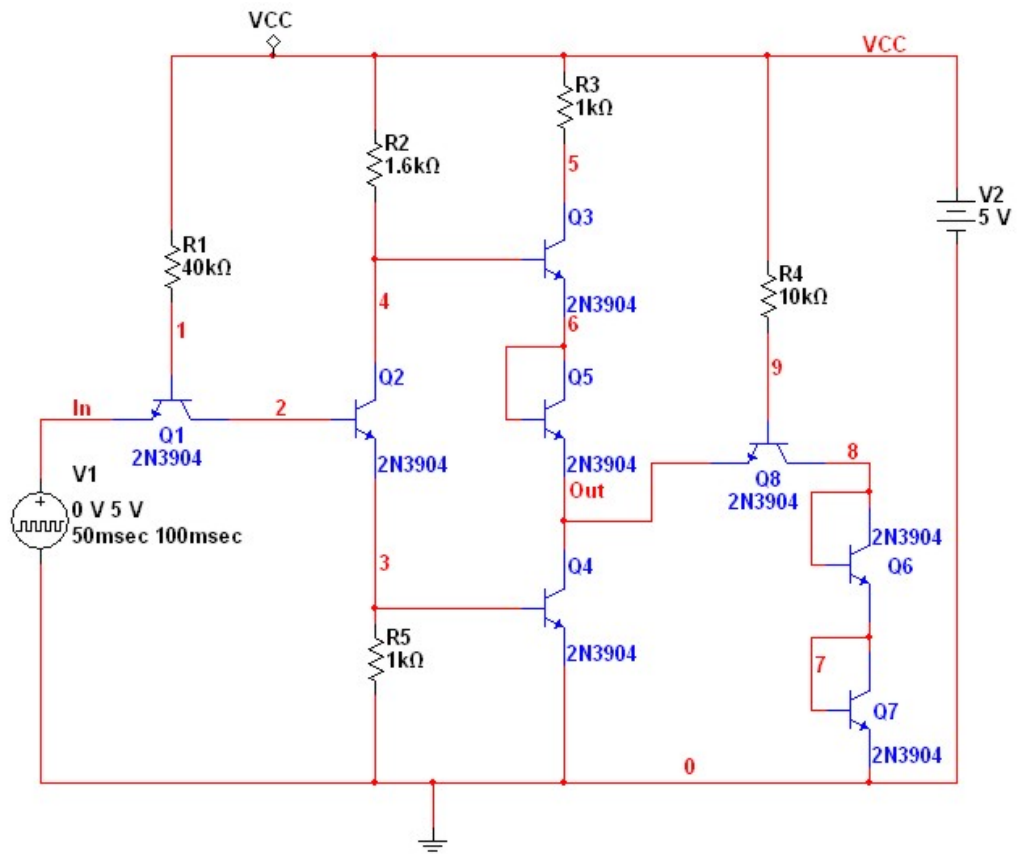

Figure 5.46: TTL inverter.

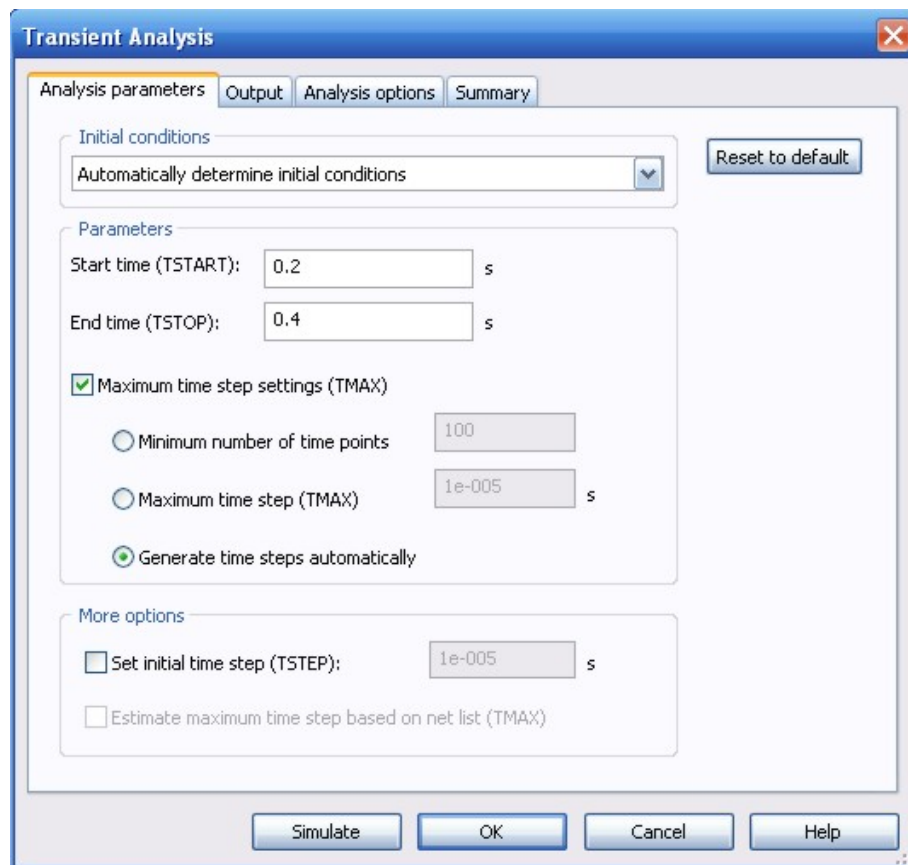

Figure 5.47: Dialog window to specify the transient analysis parameters.

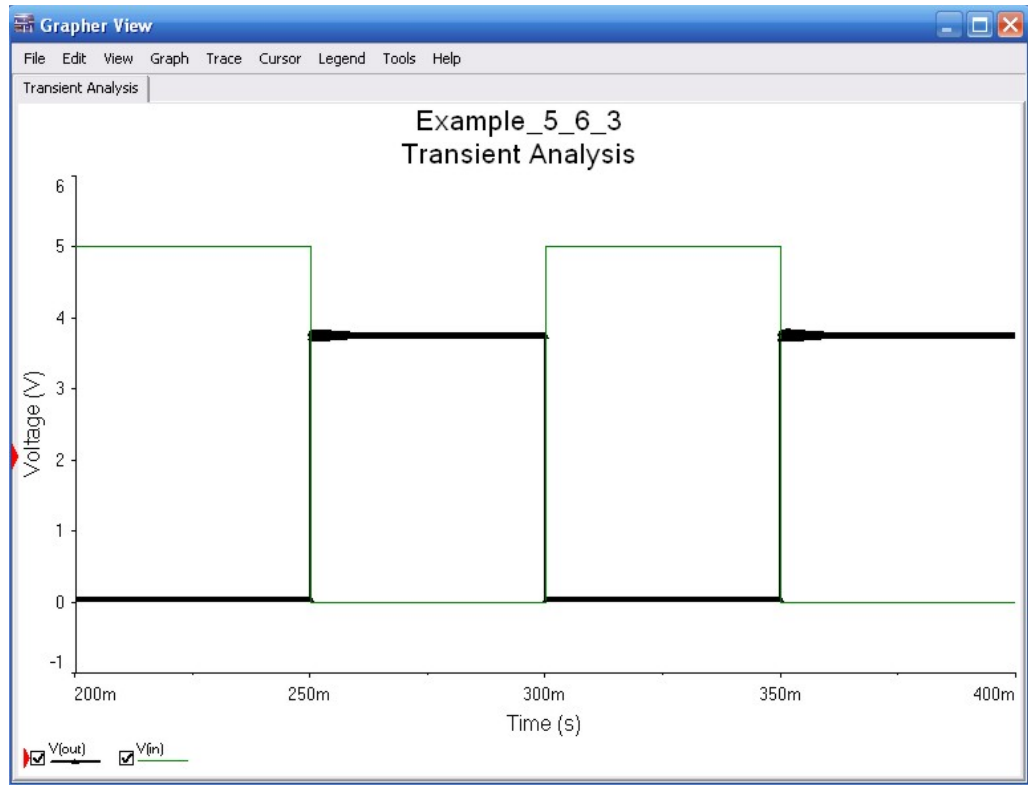

Figure 5.48: Input and output waveforms.

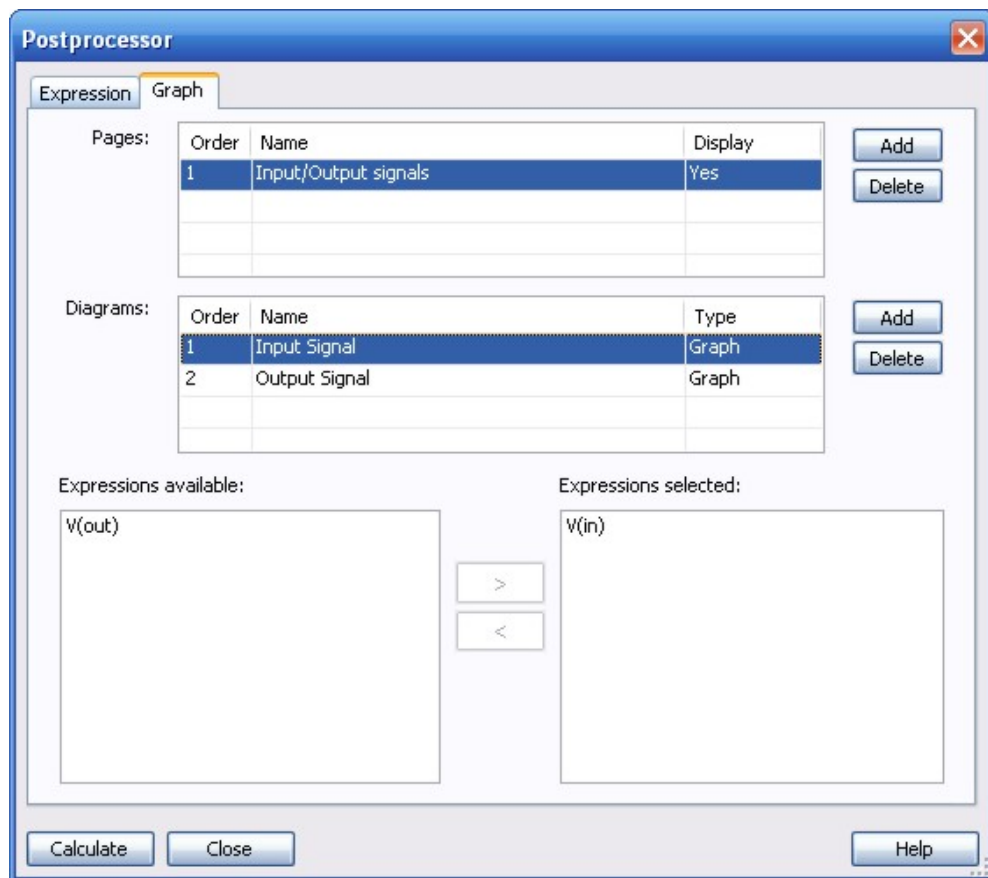

Figure 5.49: Postprocessor window to create a plot with two sets of axes.

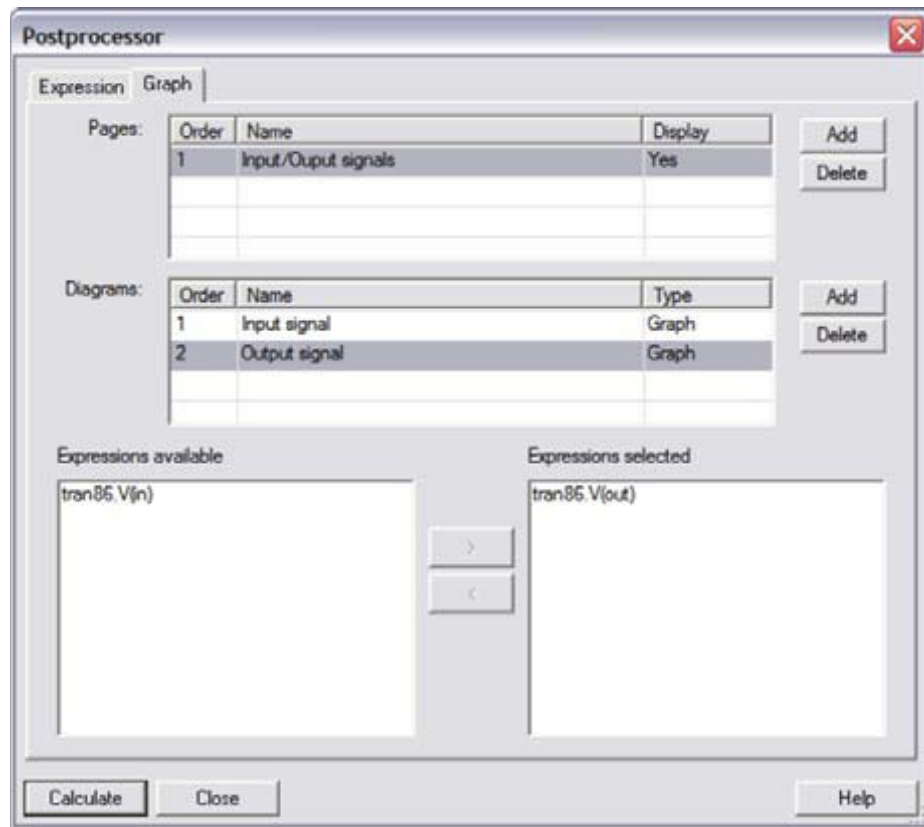
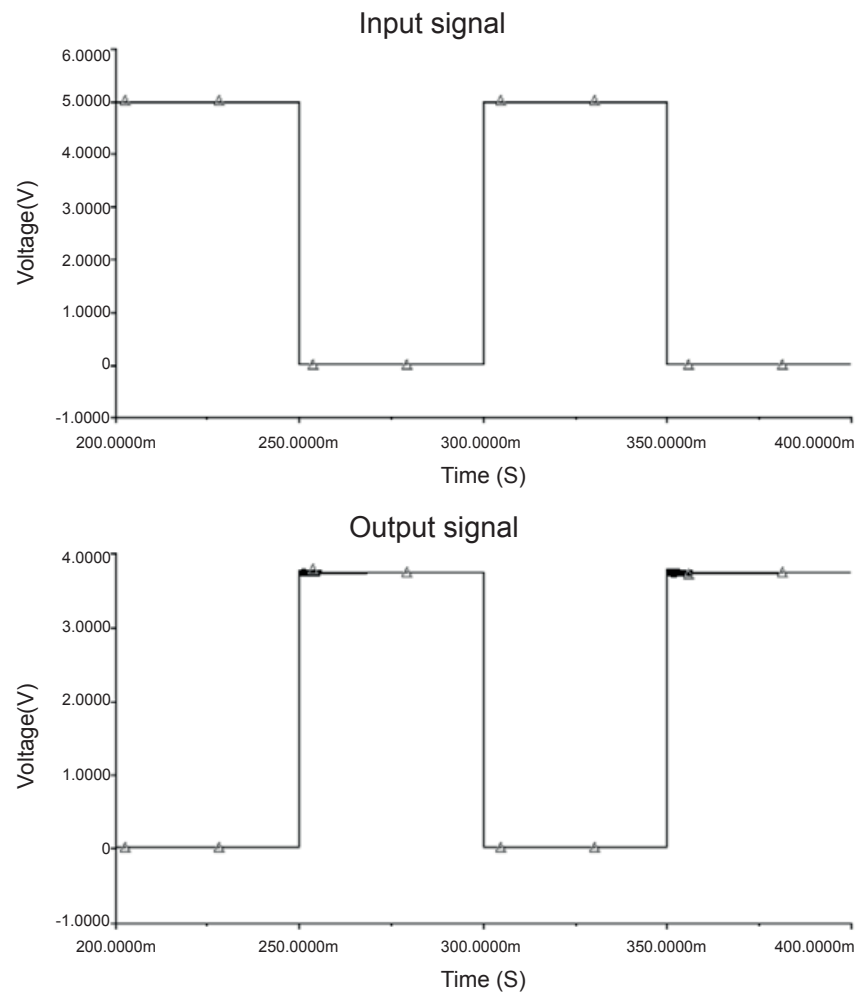

Figure 5.50: Postprocessor window to plot  $V(\text{out})$  in the Output signal axes.



**Figure 5.51:** Input and output waveforms in separate sets of axes.

## PROBLEMS

- 5.1. Plot the magnitude and phase of the circuit shown.

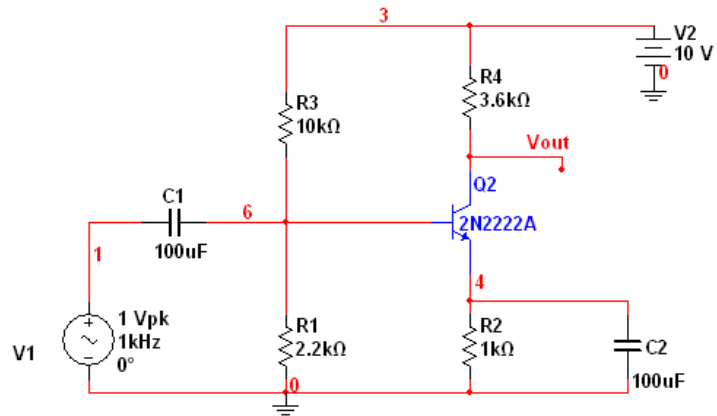

- 5.2. Plot the transistor curves for a MOSFET BF998.
- 5.3. The circuit shown is a voltage doubler. Plot the output signal and the input voltage given by the voltages  $V(1) - V(2)$ .

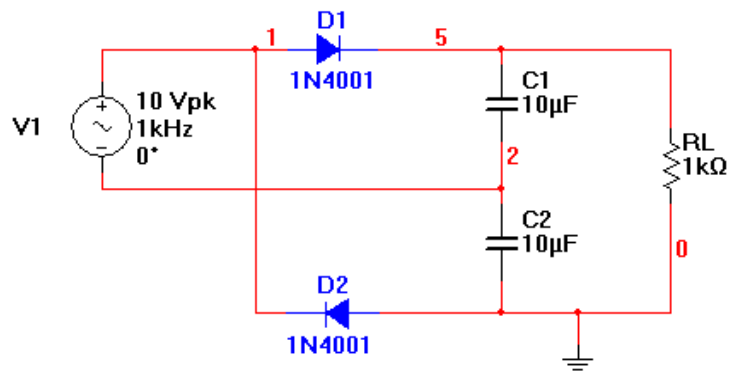

- 5.4. Use the oscilloscope to see the waveforms indicated. This is a common-emitter amplifier.



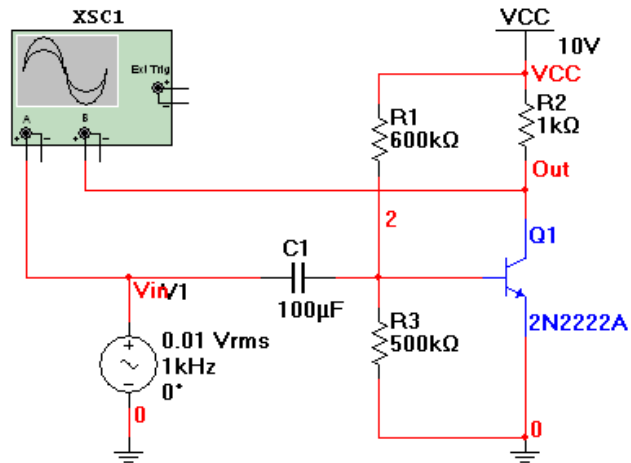

5.5. The circuit is a clamper. Plot the signal at node 2.

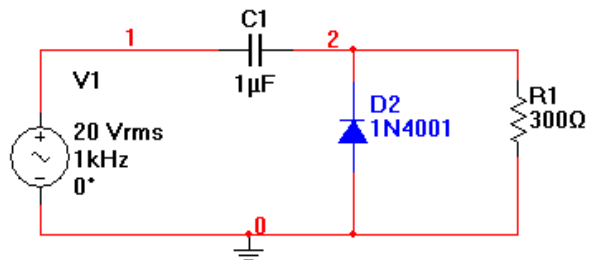

5.6. Perform a transient analysis to the differential circuit shown to obtain the input and output waveforms.

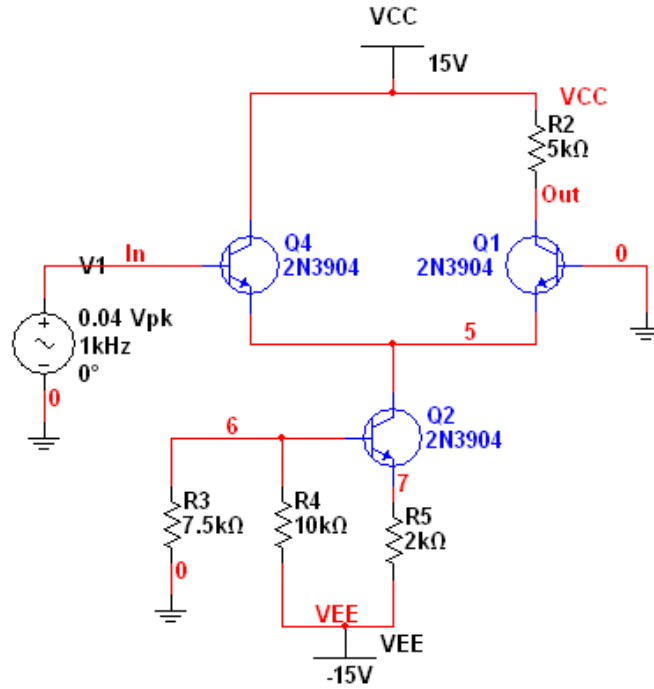

- 5.7. Use a programmable unijunction transistor UJT to build an oscillator as shown in the figure. Measure the waveform at node 1.

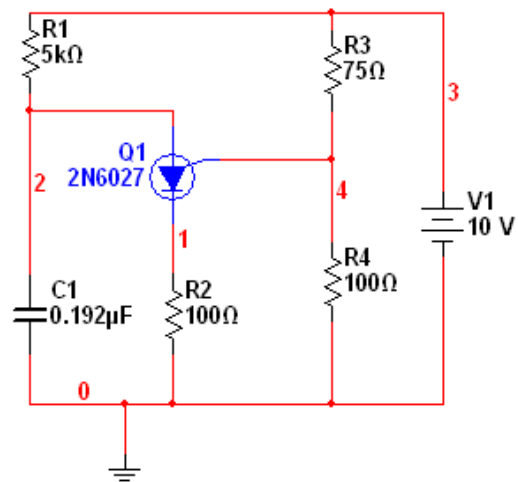

- 5.8. Simulate the amplifier shown. It employs a JFET as the amplifying device. Plot the output waveform.

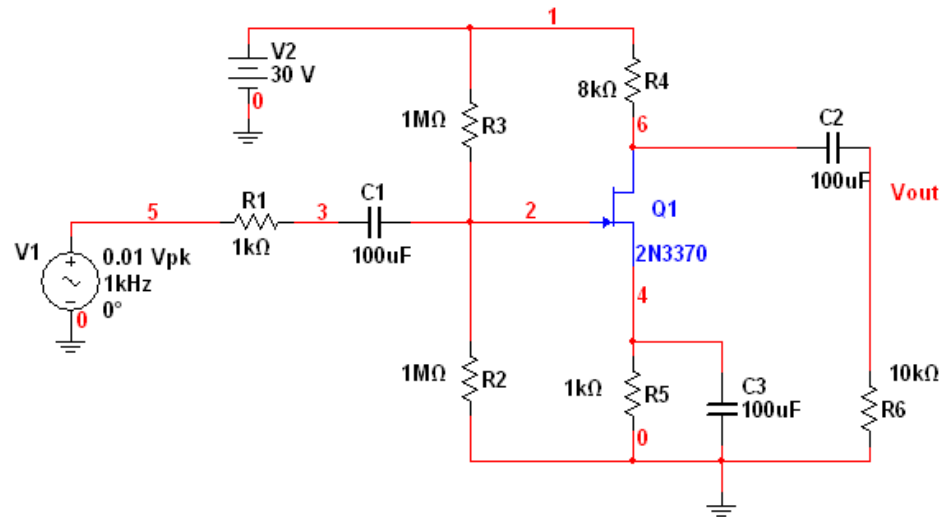

- 5.9. The circuit is a cascode amplifier implemented with JFETs. Find the gain and plot it after a transient analysis.
- 5.10. Plot the input and output waveforms for the two-stage circuit.

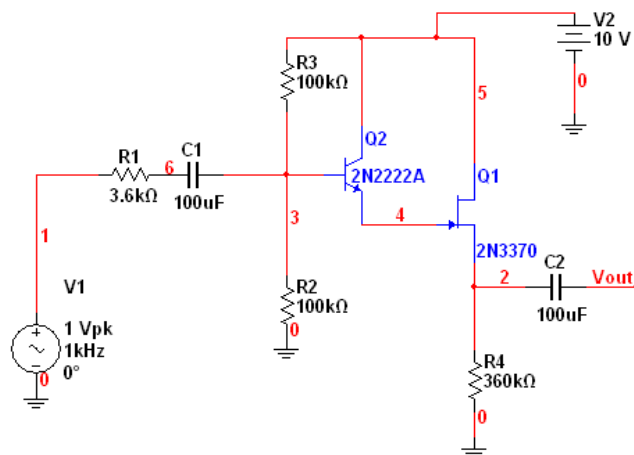

**SELECTED BIBLIOGRAPHY**

For readers interested in further reading about simulation, the following books provide further insight into the SPICE simulator.

- [1] U. Cilingiroglu, *Systematic Analysis of Bipolar and MOS Transistors*, Materials Science Library, 1993. 119, 142
- [2] H. Schichman and D. A. Hodges, "Modeling and simulation of insulated-gate field-effect transistor switching circuits," *IEEE Journal of Solid-State Circuits*, SC-3, 285, September 1958. 139
- [3] A. Vladimirescu, and S. Lui, "The Simulation of MOS Integrated Circuits Using SPICE2," Memorandum No. M80/7, February 1980. 139
- [4] B. J. Sheu, D. L. Scharfetter, P.-K. Ko, and M.-C. Jeng, "BSIM:Berkeley Short-Channel IGFET Model for MOS Transistors," *IEEE Journal of Solid-State Circuits*, SC-22, 558-555, August 1987. 139
- [5] J.H. Huang, Z.H. Liu, M.C. Jeng, K. Hui, M. Chan, P.K. KO, and C. Hu, "BSIM3 Manual," Department of Electrical Engineering and Computer Science, University of California, Berkeley, CA 94720. 139
- [6] Department of Electrical Engineering and Computer Science, BSIM3v3.1 Manual, University of California, Berkeley, CA 94720. 139
- [7] M. Bucher, C. Lallement, C. Enz, F. Theodoloz, F. Krummenacher. *The EPFL-EKV MOS-FET Model Equations for Simulation Technical Report: Model Version 2.5*. Electronics Laboratories, Swiss Federal Institute of Technology (EPFL), Lausanne, Switzerland, Updated September, 1997. 139
- [8] R.S. Murphy, *Prospects for the MOS Transistor as a High Frequency Device*, Tesis doctoral, INAOE, 1997. 139
- [9] D. Báez López, *Análisis de circuitos usando PSpice*, Alfaomega Grupo Editor, México, D.F., 1995. 139
- [10] A.S. Sedra and K.C. Smith, *Microelectronic Circuit*, Holt, Rinehart, and Winston, 2006. 128

## CHAPTER 6

# Digital Circuits

## INTRODUCTION

Digital circuits nowadays are part of our daily lives from several decades ago. Their applications go from cellular telephones to PC applications, communications systems, process control, to name a few. Multisim has a wide set of features specifically designed for the analysis and simulation of digital circuits in several handy ways.

## 6.1 DIGITAL CIRCUIT COMPONENTS

In Multisim we can find several useful tools and parts for digital circuits. They range from digital gates (both families, TTL and CMOS are supported), indicators (such as LED's, LCD displays, Logic Analyzers and Word Generators), wires, data buses and power supplies.

Mathematical models for gates can be idealized so that race conditions will not affect the final result or they can be based on real world components in the 74XX and 40XX families for TTL and CMOS, respectively.

Ideal parts don't need a dedicated power supply and can be used as stand-alone gates. When using component models from real world circuits a specific gate in a multi-gate IC can be specified and the supply voltage can be changed accordingly.

There are 4 different power supplies for digital circuits (see Fig. 6.1). The difference among

### Digital Power Supplies

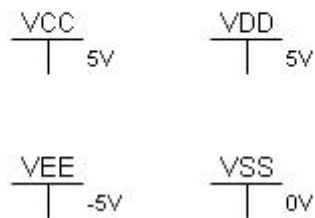

**Figure 6.1:** Digital power supplies in Multisim.

them is the value of the provided voltage. VCC is fixed at 5 VDC, VDD is the same. VEE is a negative power supply that provides 5 VDC and VSS is the same as digital ground at 0 VDC.

TTL (*Transistor-Transistor Logic*) is a family of digital gates with several subfamilies. We can see all of them if we open the parts menu and select TTL circuits. The biggest difference among the different subfamilies is the response time of each one. The most widely used subfamily for digital circuit simulation is the 74LSXX series where the digits after the LS indicate the gate's function. For example, 74LS00 is a NAND gate and we will use it in the next example.

### Example 6.1 Truth Table Verification.

The truth table for a NAND gate is shown in Table 6.1. We can build a circuit using a 74LS00 HEX NAND in order to verify this table. The circuit is shown in

X	Y	X NAND Y
0	0	1
0	1	1
1	0	1
1	1	0

We can see that the output will be in a low state when both inputs are at a high level.

In Fig. 6.2 we can see some aspects that we are going to discuss here. Power is provided by VCC and it is fixed at 5 VDC. Input signals are obtained using J1. This component is a 2 bit DIP switch (DIP stands for Double In-Line Package, that's the type of components that can fit into a breadboard for prototyping, their typical width is 0.3 inches and the separation between pins is 0.1 in). The switch is wired so the digital ground is going to the gate's input via a pull-down resistor, basically grounding it while the switches are open. When one or both of the switches is closed (a point on the component shows the ON position) there are 5 volts present at the input.

The output is connected to a display that evokes a test LED. It is available at the Indicators library as Probe. Besides it we can see that the threshold voltage for turning it on and off is 2.5 volts. We then run the simulation with the Run icon and we can observe the result shown on Fig. 6.3.

Here, we can see some important details:

The inputs are both LOW.

The virtual LED is on.

The virtual LED shows the threshold voltage of 2.5 VDC.

Probe1 shows a voltage of 5 volts at the output.

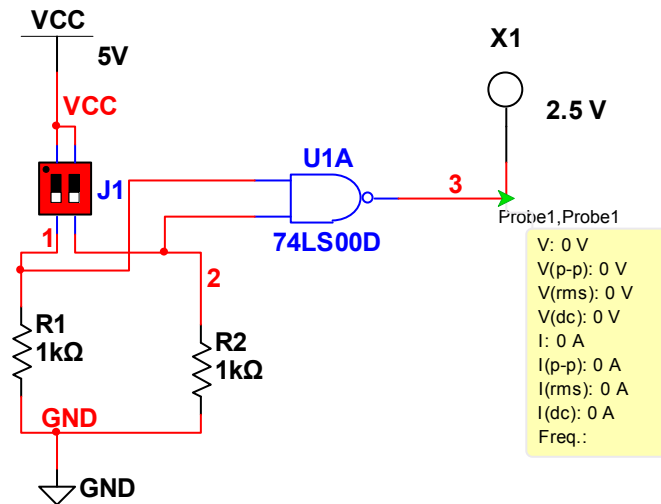

Figure 6.2: Circuit used for testing the truth table of a NAND gate.

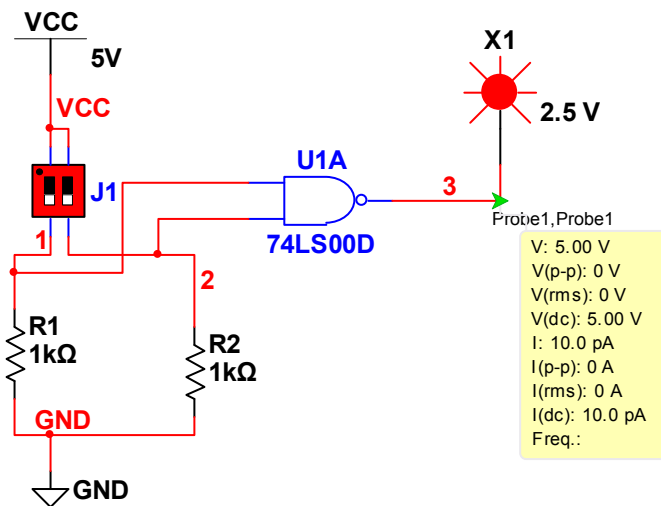

Figure 6.3: Simulation running. Note the red LED indicating a HIGH level at the output.

## 162 6. DIGITAL CIRCUITS

This simulation with only 2 bits at the input can be used to verify the truth table just flipping the switches. While the simulation is running we can change with the computer's mouse the positions of the switches.

A very handy option in Multisim is the ability to assign these switches to a specific key so changes can be made using the keyboard while the simulation is running. If we right click on the DIP switch we can see that it's possible to map each switch to a key so they can be toggled during simulation (Fig. 6.4).



**Figure 6.4:** Key mapping configuration for the DIP switch.

Another nice function in Multisim shows up when adding logic gates to a design. After selecting the gate model a window appears that lets us decide which specific gate in the package we will be using (see Fig. 6.5). This function is particularly useful when the design is intended for PCB manufacturing using UltiBoard.



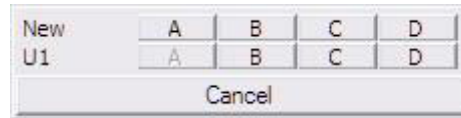
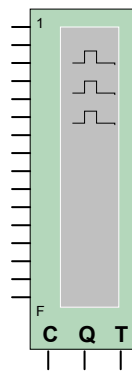

**Figure 6.5:** Gate selection window.

## 6.2 TOOLS FOR DIGITAL CIRCUIT ANALYSIS

### 6.2.1 LOGIC ANALYZER

The next tool we will need in our analysis of digital circuits is the logic analyzer. This instrument can show up to 16 input or output digital waveforms. Its inputs are on the left side and in the bottom there is a clock input, a clock qualifier and a trigger qualifier (Fig. 6.6).



**Figure 6.6:** Logic analyzer.

Trigger functions allow us to save data in a buffer when a trigger condition is met. This buffer will save data before and after the trigger condition according to the size specified in the properties dialog window.

### 6.2.2 WORD GENERATOR

In a digital circuit, digital stimuli can be generated with DIP switches but there is also another tool that is really convenient when working with specific series of data (counting sequences, arbitrary progressions, etc.). This tool is called the Word Generator.

As the word generator is a data source the majority of its connections are outputs. It also has a trigger input for it to start when an external signal is present at the input and it also has a ready output for telling other devices it is ready to start generating the data it is programmed to.

Data can be cyclic, only a burst or advance in steps. This behavior can be defined in the properties window of the Word Generator. A total of 32 signals can be used and they can be entered as binary, hexadecimal or decimal. There is a list of predefined sequences also. They can be selected pressing the set button from inside the properties window.

For our next example we are going to generate a 3 bit binary count as shown in Fig. 6.7.

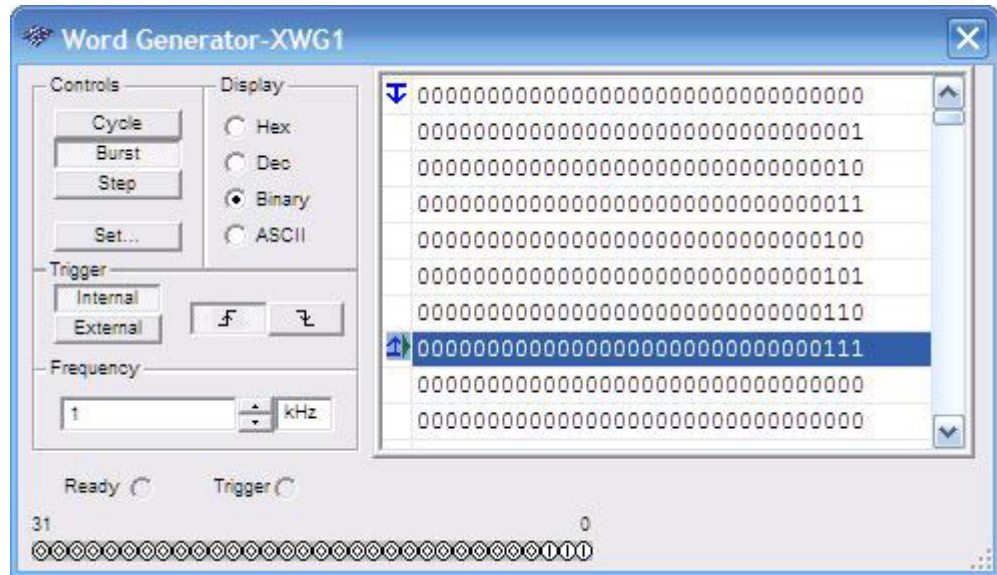

**Figure 6.7:** 3-bit binary count.

This binary count will be the input data for a full adder circuit.

Input waveforms have to be connected to inputs A, B, and Cin. They represent the operands and the carry input, respectively.

If we plot both input and output waveforms with the logic analyzer we get the signals shown on Fig. 6.9.

The complete circuit with all the connections made is shown in Fig. 6.10.

### 6.2.3 LOGIC CONVERTER

A logic converter is a special tool in Multisim. This device does not have a real word version of itself. It is a tool for working with digital circuits, logic expressions and / or truth tables. This is a list of its functions:

From gate implementation to truth tables.

From truth table to a boolean logic function.

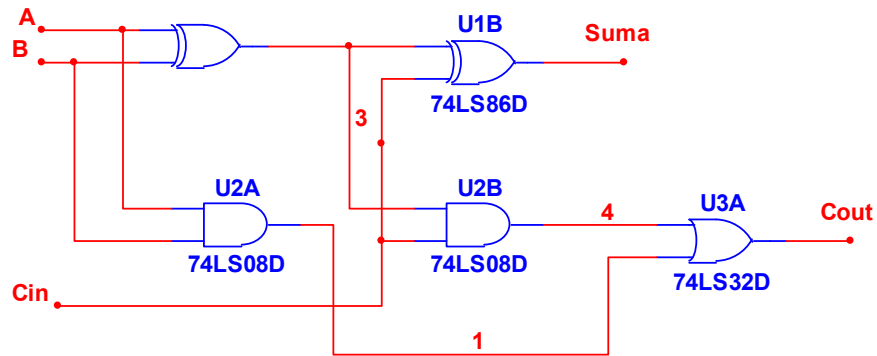

Figure 6.8: Full adder circuit.

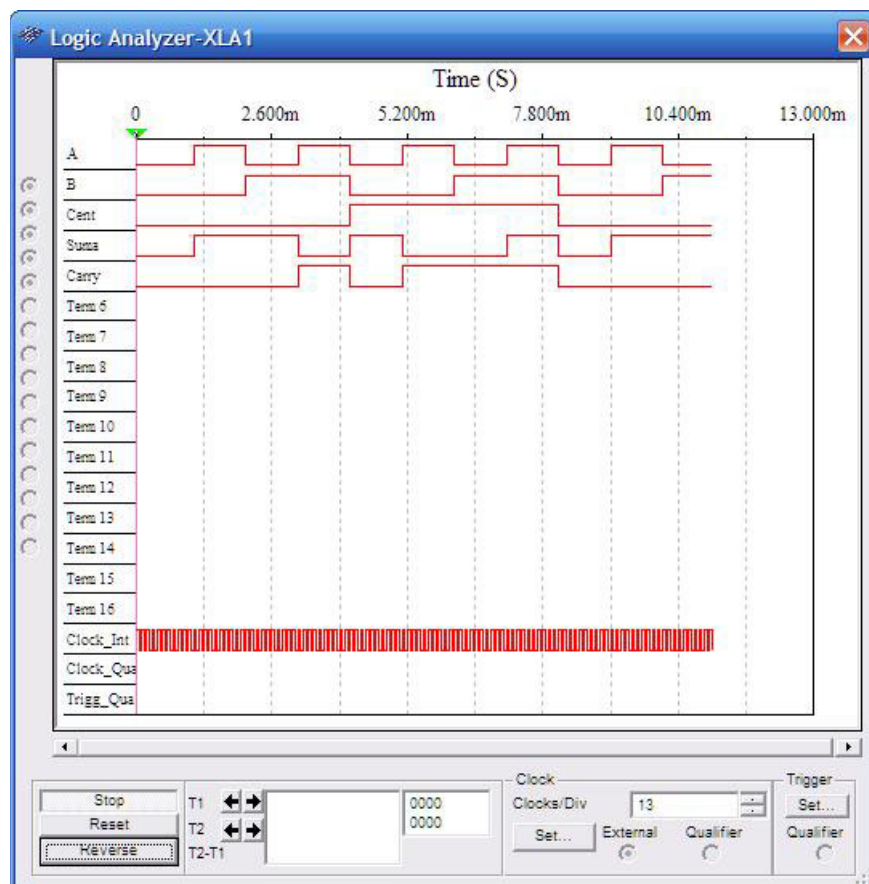
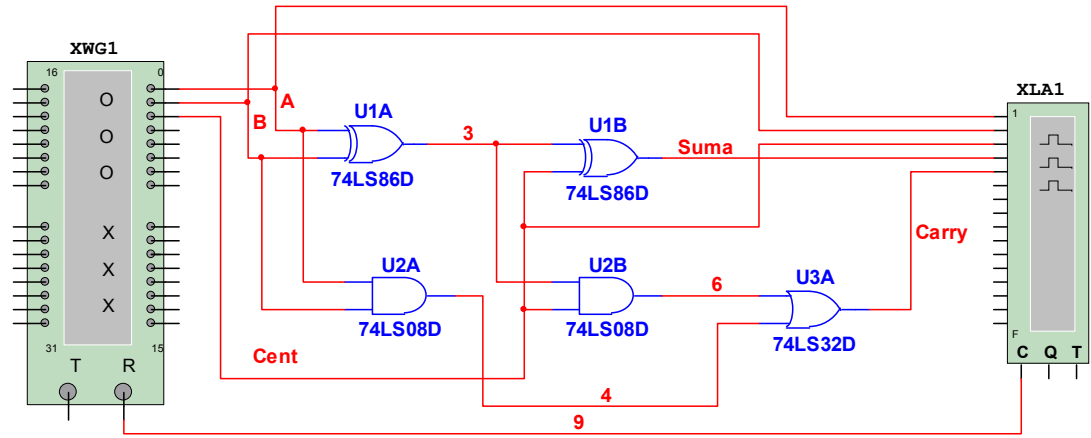

Figure 6.9: Input and output waveforms for a full adder circuit.



**Figure 6.10:** Full adder with instrument connections.

From truth table to a simplified gate implementation.

From boolean logic function to truth table.

From boolean logic function to a gate implementation.

From boolean logic function to a NAND gate implementation.

As an example we will test a 3 bit parity generator (Fig. 6.11).

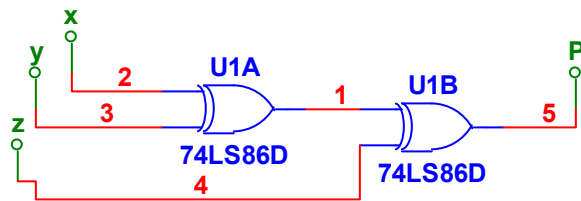

**Figure 6.11:** 3 bit parity generator circuit.

We are going to connect the logic converter to the circuit inputs X, Y, and Z. This will correspond to the A, B, and C connections on the logic converter. Output P is going to *Output*. The connections can be seen on Fig. 6.12.

Inside the options for the logic converter we need to press the first button in order to execute the conversion between electric gates to a truth table. We will see a result similar to the one shown on Fig. 6.13.

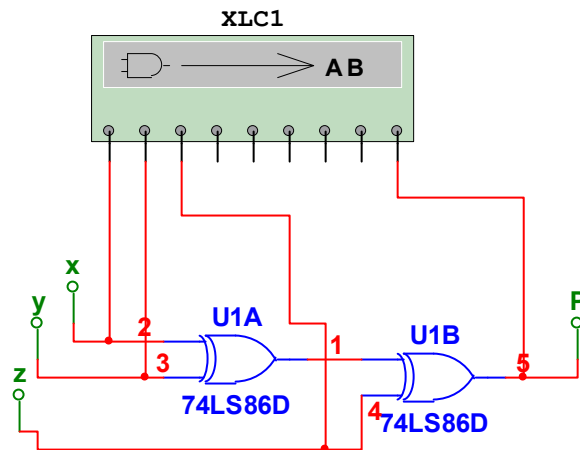

Figure 6.12: Connecting the logic analyzer to a circuit.

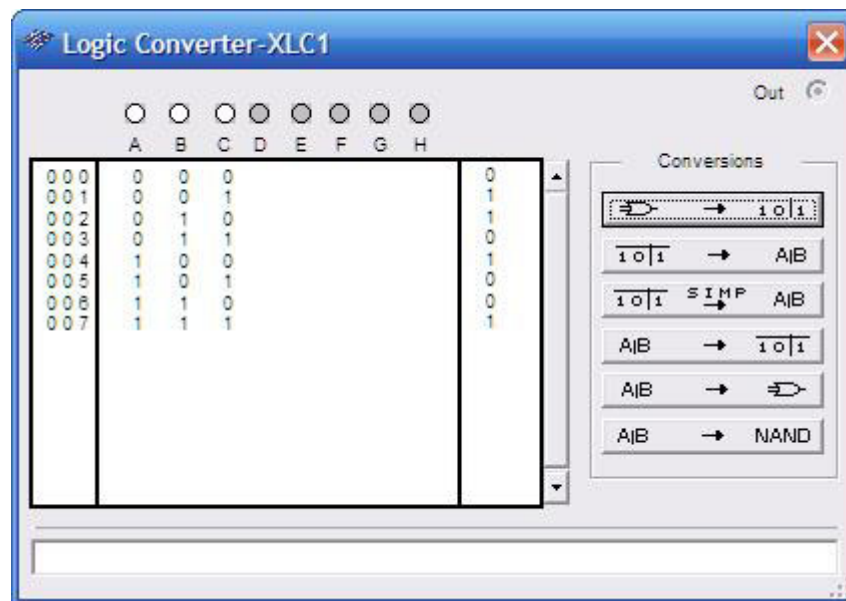
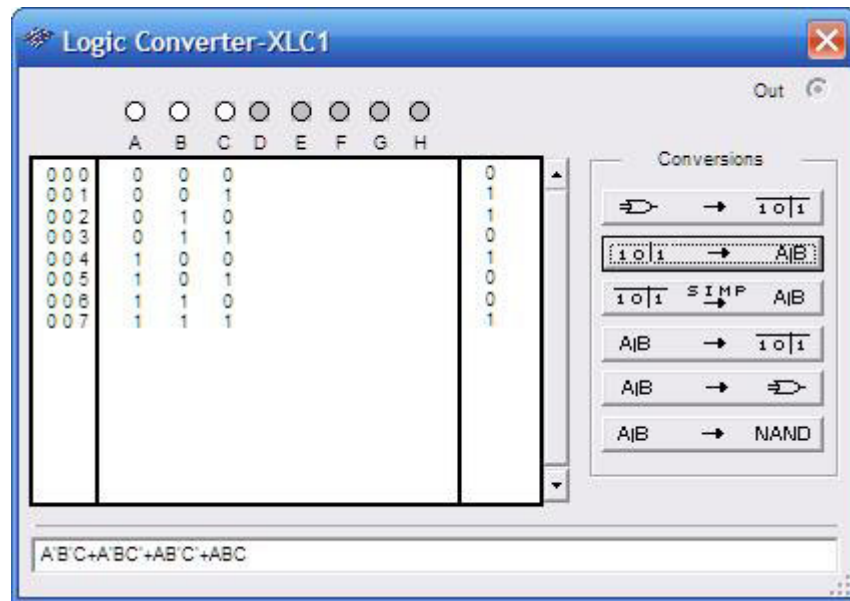

Figure 6.13: Resultant conversion going from gates to truth table.

In Fig. 6.13 we can see that an electrical gate implementation can be converted to a truth table thanks to the logic converter. In the table we can also verify that the output is true when the number of zeros at the input is an even quantity.

The next step is to obtain the boolean logic expression for the truth table we already have. The expected result is a function implemented with XOR operations  $P = x \oplus y \oplus z$ . In this case, we will obtain a function expressed as a sum of products. The results are shown on Fig. 6.14.



**Figure 6.14:** Logical function obtained from the truth table.

Here, we conclude our revision of the instruments in Multisim focused on digital circuits. In the next section, we will work out three more examples so the reader can gain more familiarity with the use of Multisim in practical scenarios.

### 6.3 EXAMPLES

Parallel load register.

555-based VCO.

3–8 decoder.

**Example 6.2 Parallel load register.**

The circuit we will simulate is a 4 bit register capable of holding data in its outputs when the load signal goes high. It will also have a control line for clearing the outputs. The circuit can be seen in Fig. 6.15.

The results of a simulation can be seen on Fig. 6.16. Here we see the four input signals (IN1..IN4), the four output signals (out1..out4) and control signals (LOAD, CLR, and CLK). Input data is 0110 and we can see that the four output signals are low. When the LOAD signal goes high the output doesn't change. Two conditions must be met to have a change at the output, the CLK signal must be active when the LOAD signal is going down. That is the case when we can see data present at the output. We can also observe that the CLR signal effectively clears the output. This signal does not depend on the clock signal for clearing the output.

**Example 6.3 555-Based VCO.**

There is an interesting story about the 555 integrated circuit. In 1970 an engineer named Hans Camenzind designed a simple circuit capable of providing a stable clock signal for digital circuits. His design was bought by a company named Signetics and they were able to manufacture the whole circuit on a silicon chip. The rest, as they say, is history.

In this example we will work out a voltage-controlled oscillator based on a 555 timer. Multisim has a wizard dedicated to calculate values for astable and monostable modes of operation so we will focus on building a circuit with a variable voltage at the input and at the output we expect to see a corresponding variable square wave.

We will start with the circuit shown on Fig. 6.17.

The input signal comes from the function generator with the parameters shown on Fig. 6.18. The parameters are: frequency = 1 kHz, amplitude = 4 V and offset = 6 V.

The timer oscillates at a frequency controlled by the voltage present in the control terminal (pin 5). The period is equal to 1 ms. We can see that as the control voltage rises so does the frequency of the output signal (Fig. 6.19).

**Example 6.4 3-to-8 line decoder.**

In this example, we will use a few logic gates to build a decoder circuit. A decoder circuit reads data on its inputs and then it activates a signal on the output side corresponding to the input combination.

Here, we are using 8 AND gates and 3 NOT gates. We can see the whole circuit on Fig. 6.20.

We can show that for each combination at the input only one output will be on a HIGH state. For this task we will use the word generator and then the logic analyzer. The corresponding waveforms can be seen on Fig. 6.21.

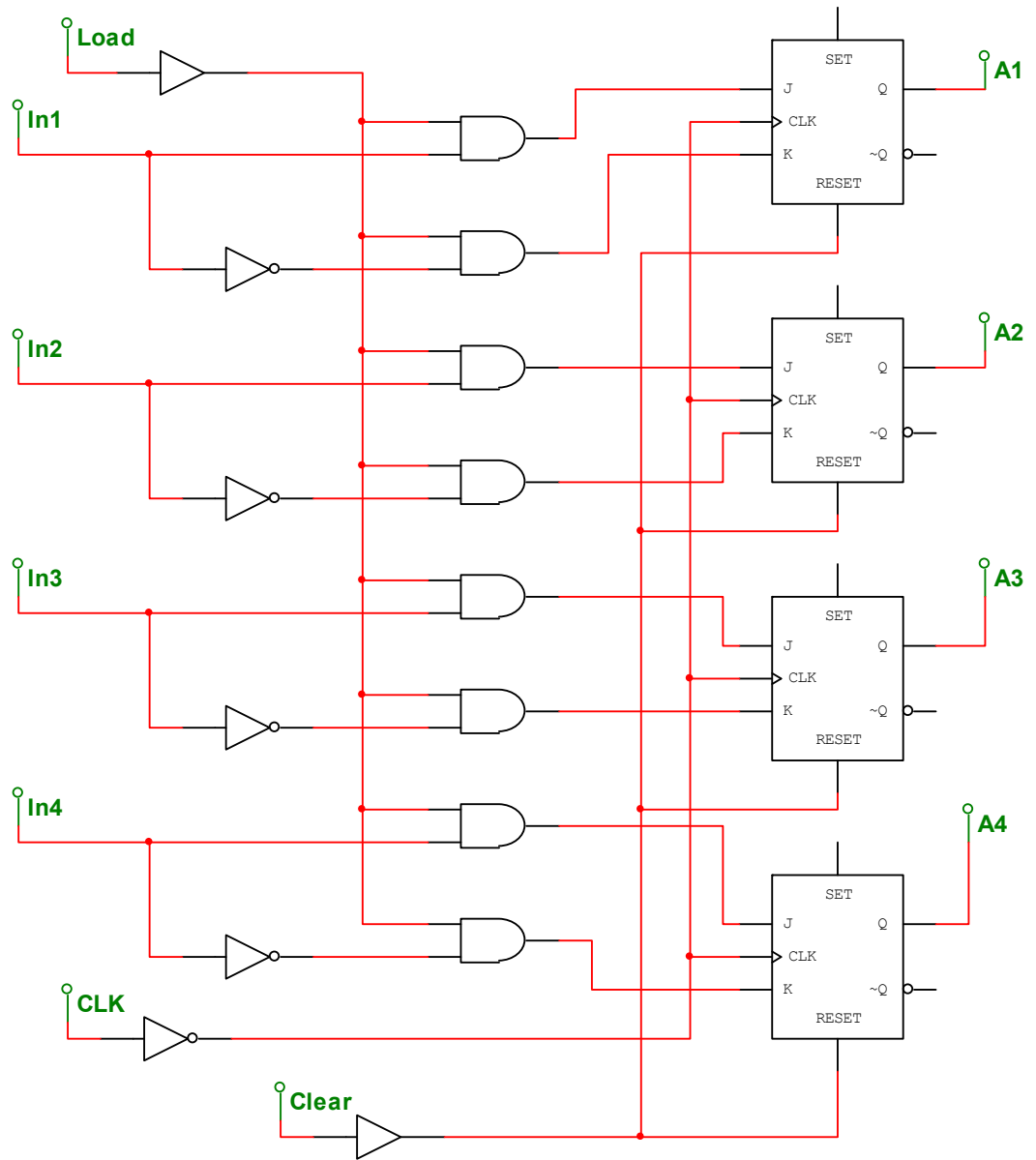

Figure 6.15: Parallel load register circuit.



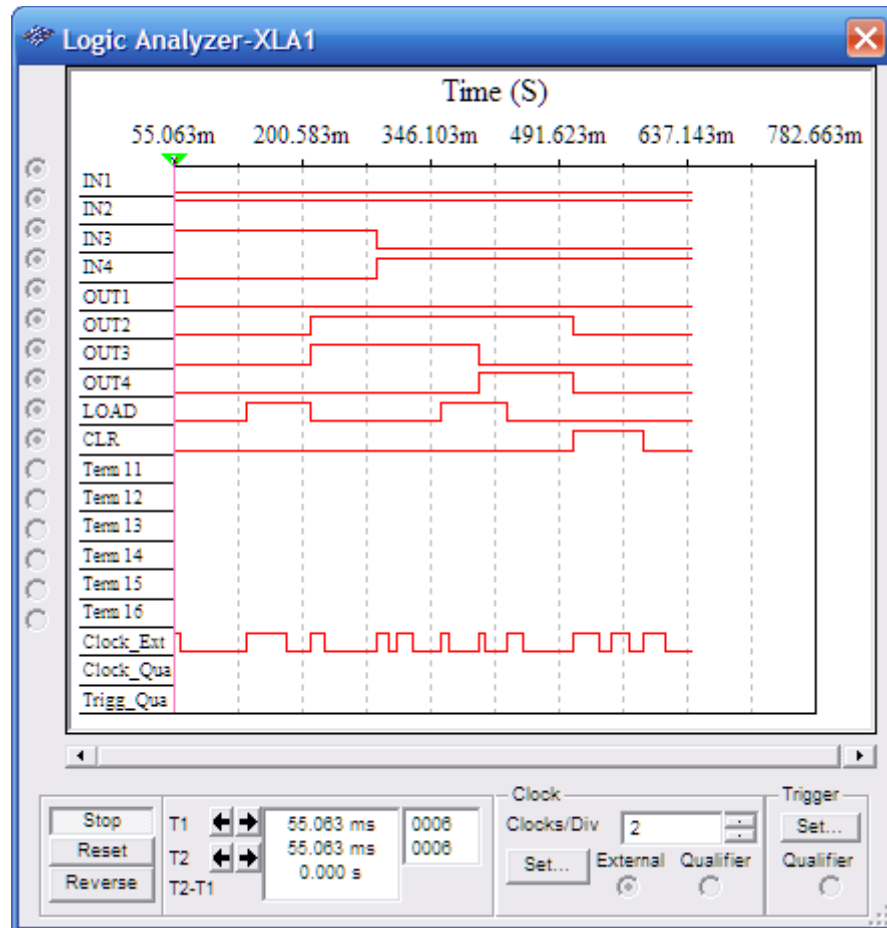

Figure 6.16: Parallel Load Register Simulation.

## 6.4 CONCLUSIONS

In this chapter, we went through a series of examples showing the analysis and simulation possibilities that Multisim provides to the user. We first introduced the common components (logic gates and digital sources) and the appropriate tools for input and output signals.

Digital circuit design, analysis, and simulation can be daunting tasks but Multisim provides several useful tools. We have shown the basic procedures for accomplishing these tasks. The provided examples cover several analysis options and show the usage of the included Multisim tools.

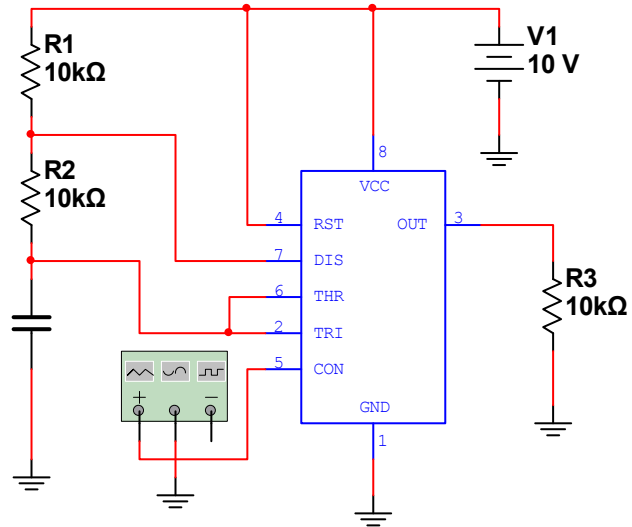

Figure 6.17: Circuit for a 555-based VCO.

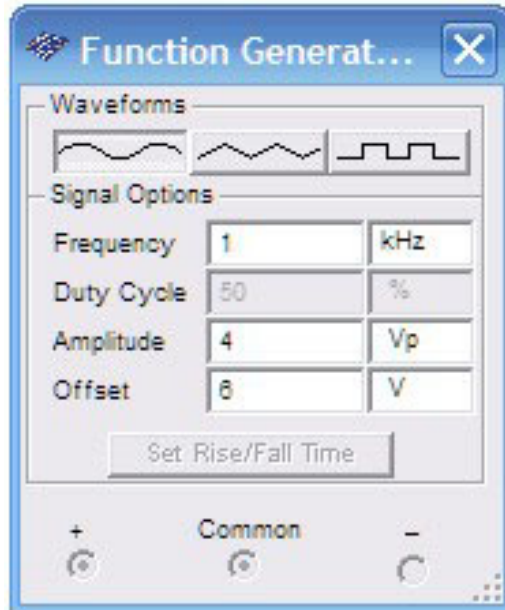

Figure 6.18: Function generator settings.

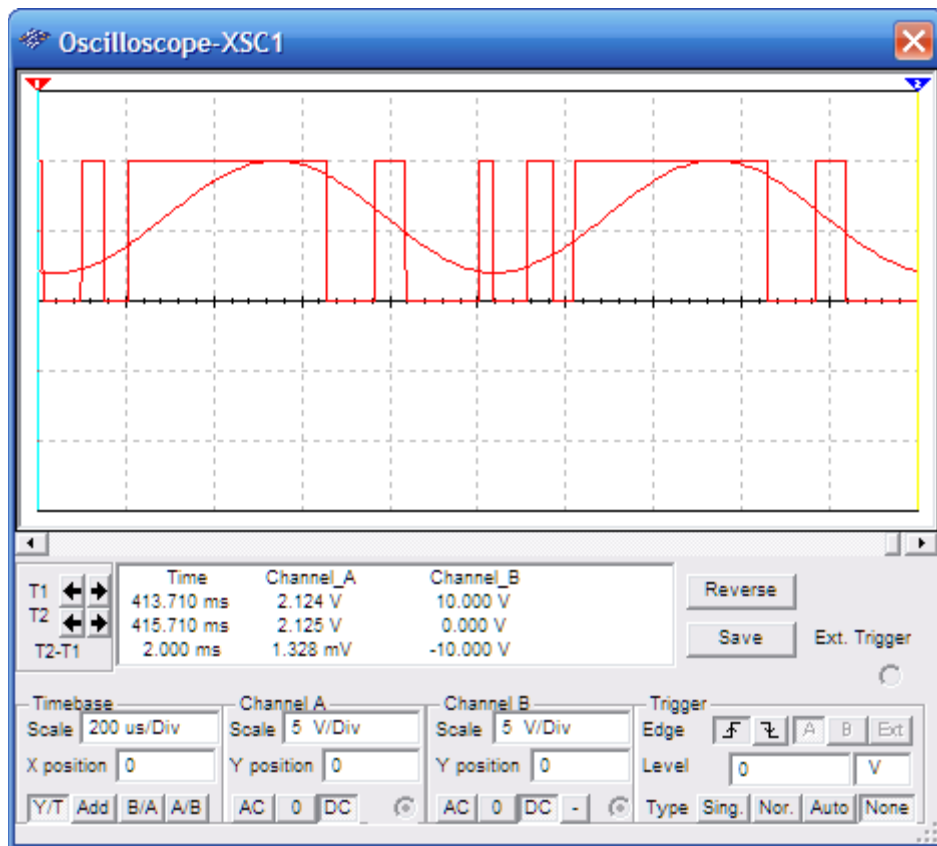

Figure 6.19: VCO input and output waveforms.

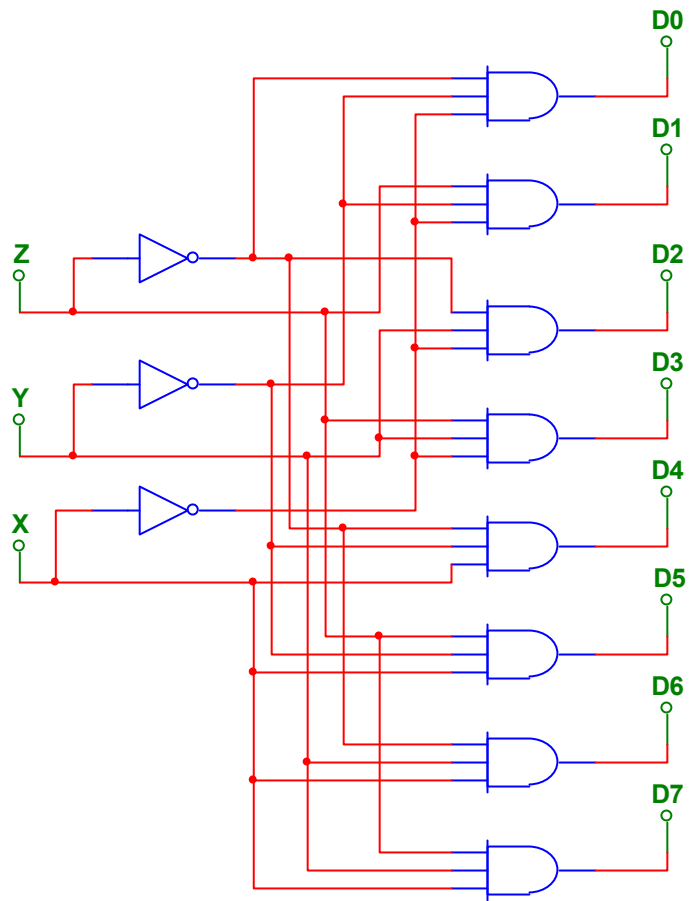

Figure 6.20: 3-to-8 decoder circuit.

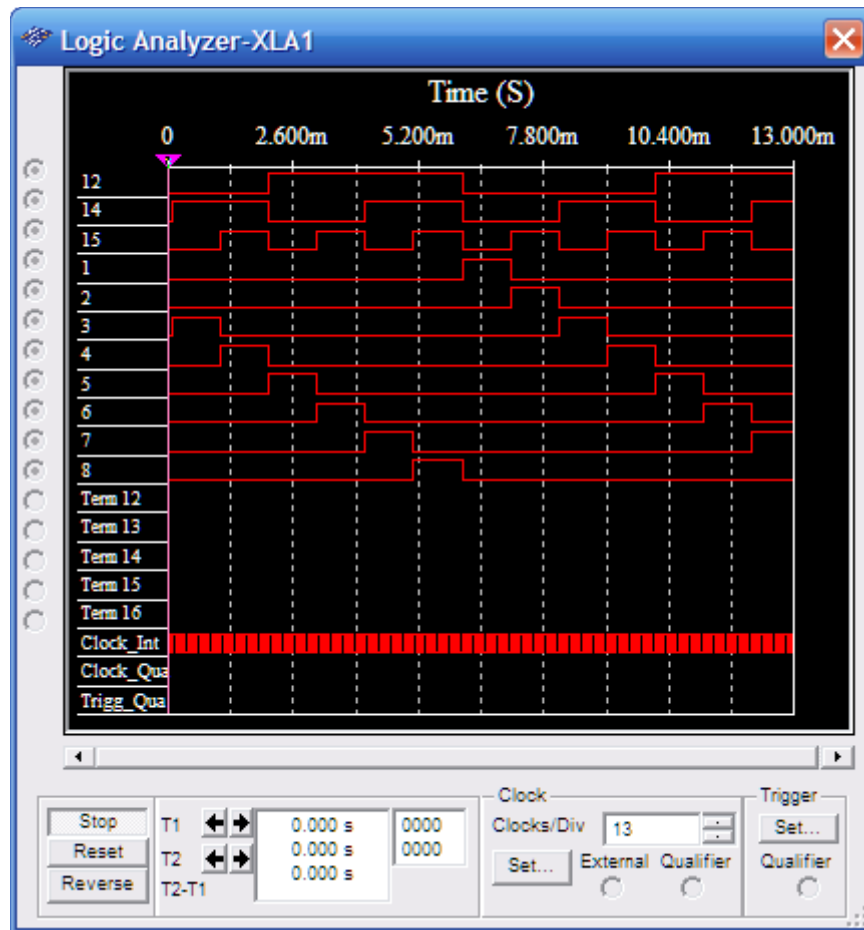
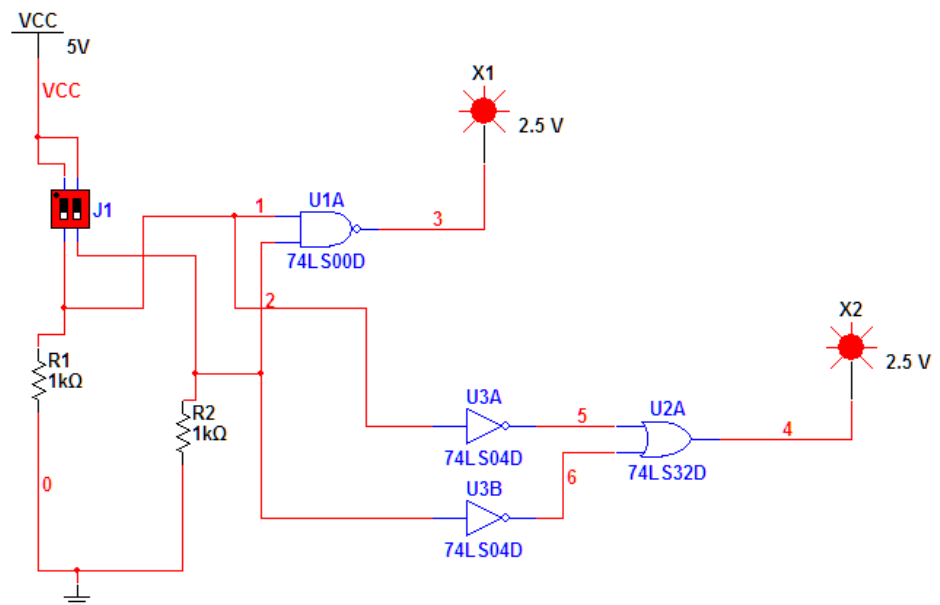

Figure 6.21: 3-to-8 decoder waveforms.

## PROBLEMS

- 6.1. If  $F1 = (A \cdot B)'$  (like in the circuit shown in Fig. 6.2), build a test circuit for another function  $F2$  that is the DeMorgan equivalent to  $F1$ . Use a DIP switch and a logical probe to verify your answer.



- 6.2. Test the distributive property. Verify that  $F3 = A + (B \cdot C)$  is equal to  $F4 = (A+B) \cdot (A+C)$ . You can use truth tables, a logic analyzer or even two parallel circuits with the same inputs and independent output probes as in Problem 6.1.
- 6.3. Test the function  $F = AB'C + A'B' + C$ . Use DIP switches and compare with the truth table.



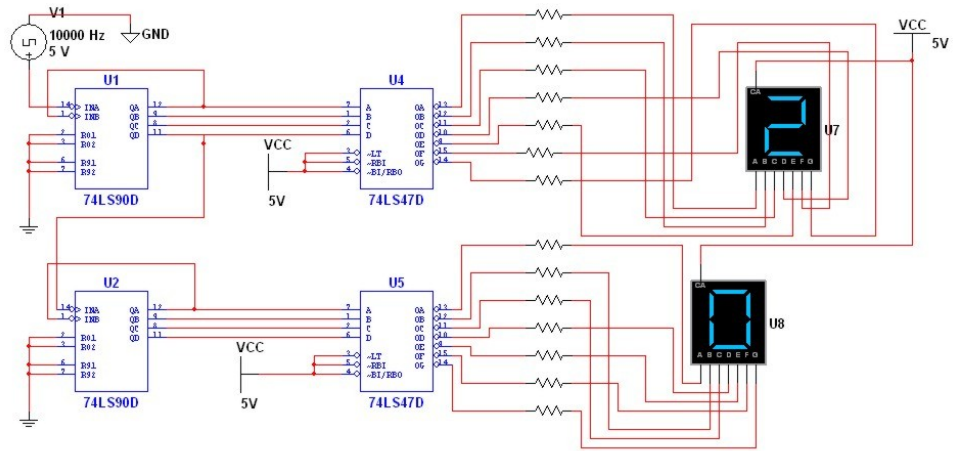

6.6. The circuit shown uses a common cathode seven-segment display. The IC 7448 is a binary to BCD. The word generator is set as shown. "Wire-up" and test the circuit.

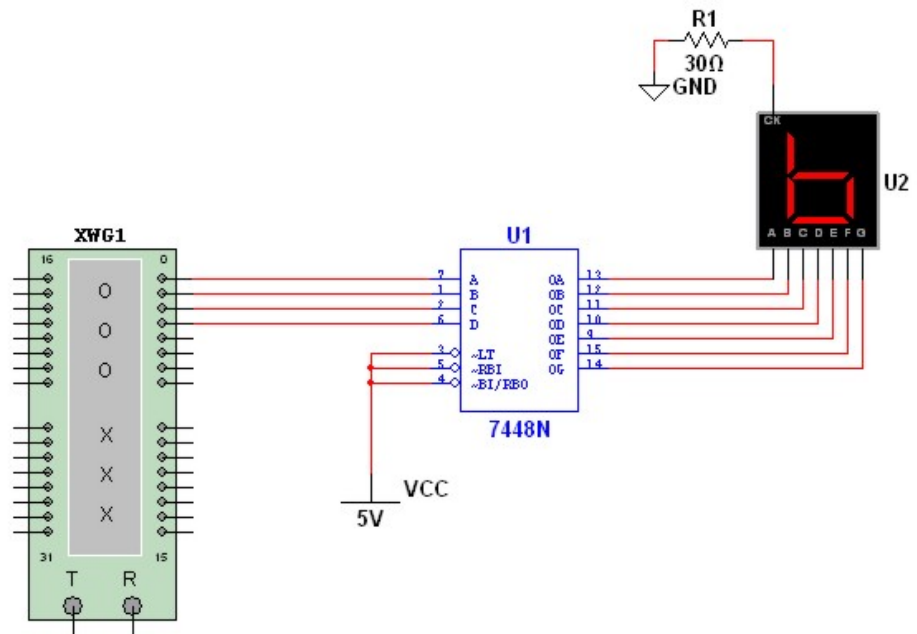



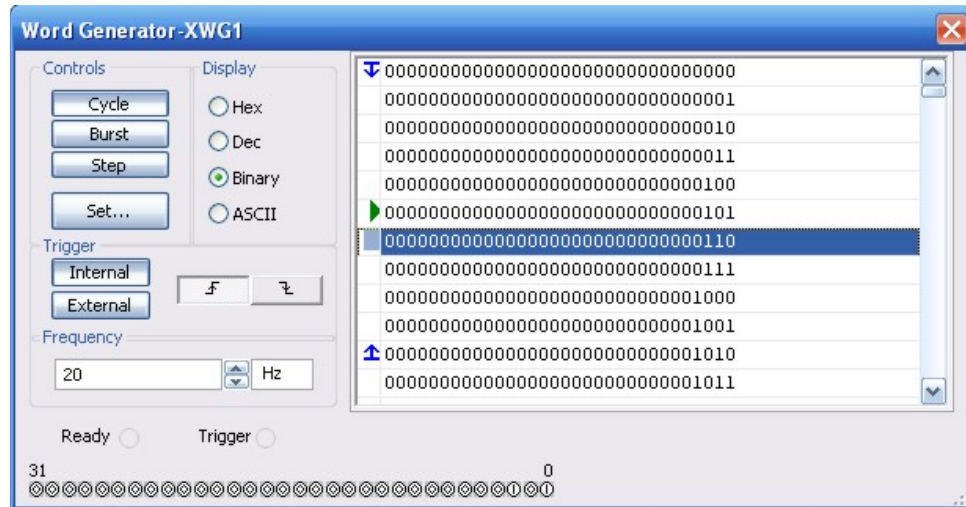

6.7. The circuit shown is a 4-bit register. Wire it and change the input (switch J1) to see how it works. Try opening and closing the load and reset switches. Set the input with the J1 DIP switch.

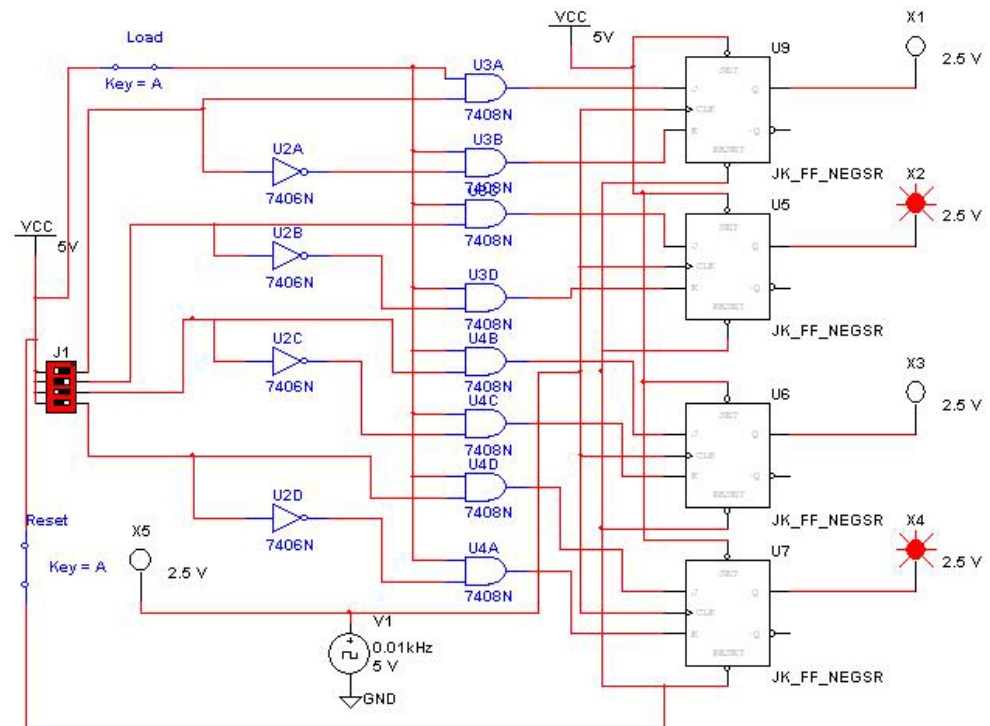

180 6. DIGITAL CIRCUITS

- 6.8. Wire-up the circuit shown and check its output. It is a voltage-controlled oscillator. Its frequency is controlled by the voltage source V2. Try several values for the value of V2 and check the frequency on the frequency counter

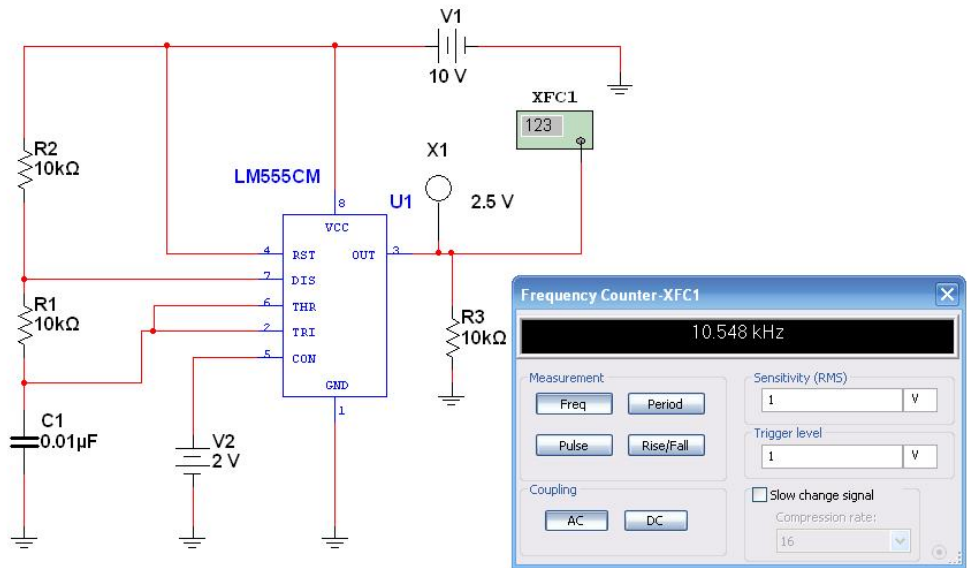

## Authors' Biographies

### DAVID BÁEZ-LÓPEZ



**David Báez-López** was born in Puebla, México. He attended the Universidad Autónoma de Puebla where he obtained a B.S. in Physics. He then obtained M.S. and Ph.D degrees in Electrical Engineering from the University of Arizona. He has authored more than 80 research papers and 5 books. He has been a professor of Electronics at Universidad de las Américas-Puebla, UDLAP, in Cholula since 1985 where he was Head of the Department from 1988 to 1996, at the National Institute for Astrophysics, Optics, and Electronics, from 1979 to 1985, where he was also head of the Department of Electronics from 1983 to 1985, and he has been a visiting professor and researcher at Texas Tech University at Lubbock, TX, and at Ryerson University, Toronto, Canada.

He is founder of the International Conference on Electronic Engineering CONIELECOMP, held every other year at UDLAP.

## FÉLIX GUERRERO-CASTRO



**Félix E. Guerrero-Castro** is an electronics engineer working at Hackerspace (<http://www.hackerspacecholula.org>) in Cholula, Puebla, México. Among his daily activities are hardware development, consulting, web programming, and teaching kids how to program Arduino microcontrollers.

After receiving his Master's Degree in Electronics in 2004, he spent six year as a lecturer teaching electronics at the Electronics Lab at Universidad de las Américas-Puebla UDLAP. He holds a Bachelor's degree in Electronics and Communication Engineering from the Instituto Tecnológico y de Estudios Superiores de Monterrey (ITESM) 1999. He has published a number of research papers in power electronics, digital sound modelling, and biomedics. He also plays guitar and records local bands in his own studio. He enjoys traveling and taking landscape photographs.