

UNIVERSITY OF NORTH CAROLINA AT CHARLOTTE
Department of Electrical and Computer Engineering

EXPERIMENT 10 – BALANCED THREE-PHASE NETWORKS

OBJECTIVES

In this experiment the student will explore balanced three-phase networks by

- Learning how to make wye and delta loads connections
- Calculating power in three-phase networks
- Learning how to connect and operate two wattmeters to measure three-phase power.

MATERIALS/EQUIPMENT NEEDED

Three-Phase AC Voltage Source (200V capable)

Power Analyzer (2)

Capacitor: 1 μ F, 400 VDC Non-polarized (3)

Resistor: 1k Ω , 5W or 10W (3)

INTRODUCTION

Electric power is for the most part generated, transmitted, and distributed to loads with three-phase circuits. The most simplistic representation of a three-phase network consists of a voltage sources connected to the loads by transmission line (see Figure 10-1). Except for special cases three-phase circuits are usually operated under balanced conditions. Some of the characteristics of a balanced three-phase network are

- The source contains a set of three-phase voltages with the same amplitude and frequency and their phases separated by 120° increments.
- The impedances of the transmission line are the same.
- The impedances for the load are the same.

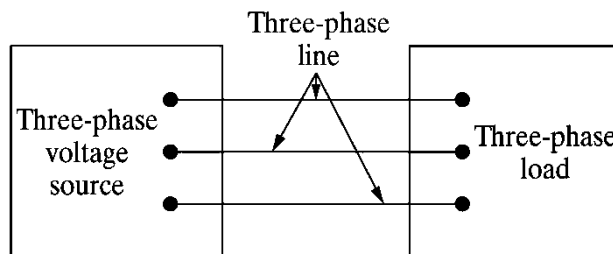
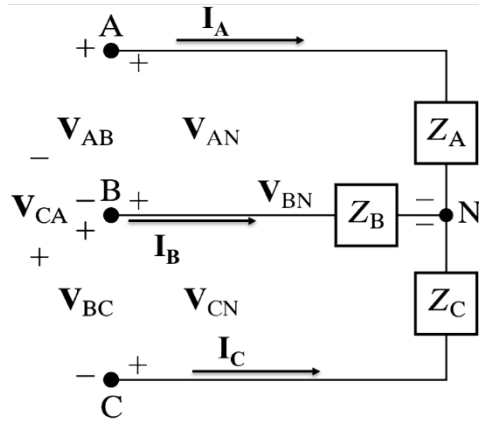

Figure 10-1 Simple representation of a three-phase system

Because three-phase sources and loads can be connected as either a wye or a delta, the circuit in Figure 10-1 represents the following possible configurations: Y-Y, Y- Δ , Δ -Y and Δ - Δ .

Balanced Wye (Y) Loads

In Figure 10-2 the relationship between the line-to-line voltages and the line-to-neutral voltages for a balance Y-connected load is presented. Note that same relationships hold true for a balanced Y-connected source.



$$Z_A = Z_B = Z_C = Z_y$$

$$I_N = I_A + I_B + I_C = 0$$

$$V_{AN} = |V| \angle \phi_{AN}$$

$$V_{BN} = |V| \angle (\phi_{AN} - 120^\circ)$$

$$V_{CN} = |V| \angle (\phi_{AN} - 240^\circ)$$

$$V_{AB} = V_{AN} - V_{BN} = |V_{AN}| \sqrt{3} \angle (\phi_{AN} + 30^\circ)$$

$$V_{BC} = V_{BN} - V_{CN} = |V_{AN}| \sqrt{3} \angle (\phi_{AN} - 120^\circ + 30^\circ)$$

$$V_{CA} = V_{CN} - V_{AN} = |V_{AN}| \sqrt{3} \angle (\phi_{AN} - 240^\circ + 30^\circ)$$

Figure 10-2 Wye Connected Load

Balanced Delta (Δ) Loads

In Figure 10-3 the relationship between the phase currents and the line currents for a balance Δ -connected load is presented. Note that same relationships hold true for a balanced Δ -connected source.

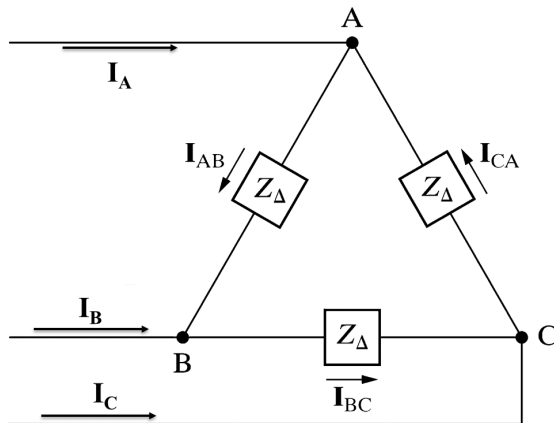

$$Z_{AB} = Z_{BC} = Z_{CA} = Z_{\Delta}$$

$$I_{AB} = |I_{\phi}| \angle \phi_{AB}$$

$$I_{BC} = |I_{\phi}| \angle (\phi_{AB} - 120^\circ)$$

$$I_{CA} = |I_{\phi}| \angle (\phi_{AB} - 240^\circ)$$

$$I_A = I_{AB} - I_{CA} = |I_{\phi}| \sqrt{3} \angle (\phi_{AB} - 30^\circ)$$

$$I_B = I_{BC} - I_{AB} = |I_{\phi}| \sqrt{3} \angle (\phi_{AB} - 120^\circ - 30^\circ)$$

$$I_C = I_{CA} - I_{BC} = |I_{\phi}| \sqrt{3} \angle (\phi_{AB} - 240^\circ - 30^\circ)$$

Figure 10-3 Delta Connected Load

Three-Phase Complex Power Calculation

For either a wye or delta balanced load the three-phase (also called total) complex power can be calculated as follows (assuming we are using RMS quantities);

$$S_{3\phi} = 3V_{\phi}I_{\phi}^* = P_{3\phi} + jQ_{3\phi}$$

$$P_{3\phi} = 3|V_{\phi}||I_{\phi}|\cos(\phi_V - \phi_I)$$

$$Q_{3\phi} = 3|V_{\phi}||I_{\phi}|\sin(\phi_V - \phi_I)$$

$$pf = \frac{P_{3\phi}}{|S_{3\phi}|} = \cos \phi_z = \cos(\phi_V - \phi_I)$$

The Two-Wattmeter Method

The total real power ($P_{3\phi}$) in a three-phase three-wired load can be measured as the sum of the readings on two wattmeters connected in any two lines with their potential coils connected to the third line as shown in Figure 10-4. Moreover, if the load is balanced it also provides a measurement of the total reactive power ($Q_{3\phi}$) and hence the total complex power ($S_{3\phi}$).

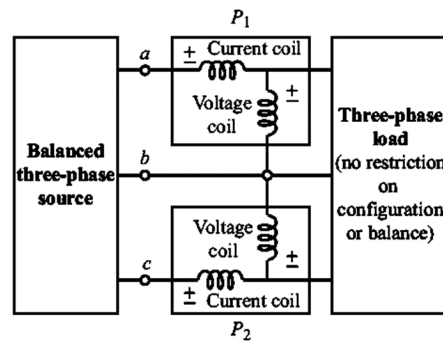

Figure 10-4 Three-phase Power Measurement with Two-Wattmeter Method

The wattmeters readings are used to calculate the total complex power in the following manner;

$$P_{3\phi} = P_1 + P_2$$

$$Q_{3\phi} = \sqrt{3}(P_2 - P_1)$$

$$S_{3\phi} = P_{3\phi} + jQ_{3\phi}$$

$$pf = \frac{P_{3\phi}}{|S_{3\phi}|}$$

It is important to note that the sign of $Q_{3\phi}$ provides information about the configuration of the load;

- $Q_{3\phi} > 0$ if the load is inductive
- $Q_{3\phi} < 0$ if the load is capacitive
- $Q_{3\phi} = 0$ if the load is resistive

PRELAB

1. For the balanced three-phase networks in Table 10-1 calculate $S_{3\phi}$, $P_{3\phi}$ and $Q_{3\phi}$. Assume a $|V_{LL}|=120V_{rms}$ and a frequency of 60Hz for the source. Each branch of the load contains a resistor ($1k\Omega$) in series with a capacitor ($1\mu F$).

Table 10-1: Three-Phase Balanced Networks for the Pre-Lab

Source-Load	$S_{3\phi}$	$P_{3\phi}$	$Q_{3\phi}$
Y-Y			
Y- Δ			

INSTRUCTOR'S INITIALS:

DATE:

PROCEDURE

Three-Phase Circuit with Wye-Load

1. Connect the Y-Y balanced three-phase network described in Table 10-1 and include the two wattmeters as shown in Figure 10-5.
2. With the voltage initially adjusted to its minimum, turn the circuit breaker to the ON position and increase it slowly until the wattmeter #1 reads a line voltage of 120V. Be careful not to exceed 120V per phase.
3. Record the two power readings (with sign), the two line voltage readings, and the two line currents in Table 10-2.
4. Turn the circuit breaker of the three-phase source to the OFF position. **Caution:** Do not make changes to the network unless the circuit breaker is in the OFF position.
5. Remove the two wattmeters from the network connection. Then, insert one of the wattmeters into one of the phases (see Figure 10-6).
6. Turn the circuit breaker of the three-phase source to the ON position. Record in Table 10-3 the phase voltage, phase current, and phase power readings.
7. Turn the circuit breaker of the three-phase source to the OFF position. **Caution:** Do not make changes to the network unless the circuit breaker is in the OFF position.

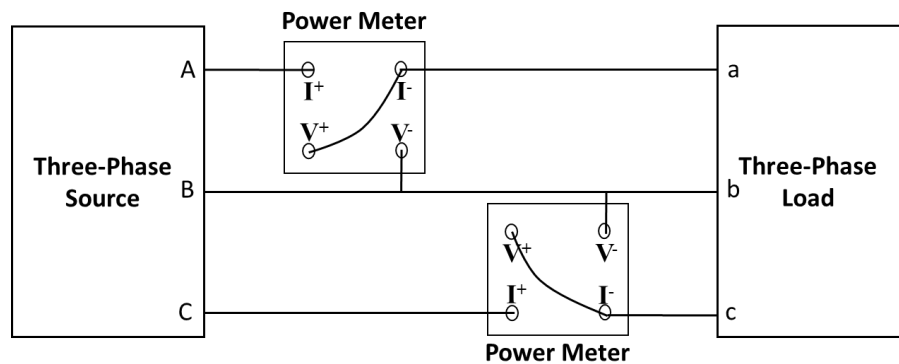

Figure 10-5 Setup for the Two-Wattmeter Method

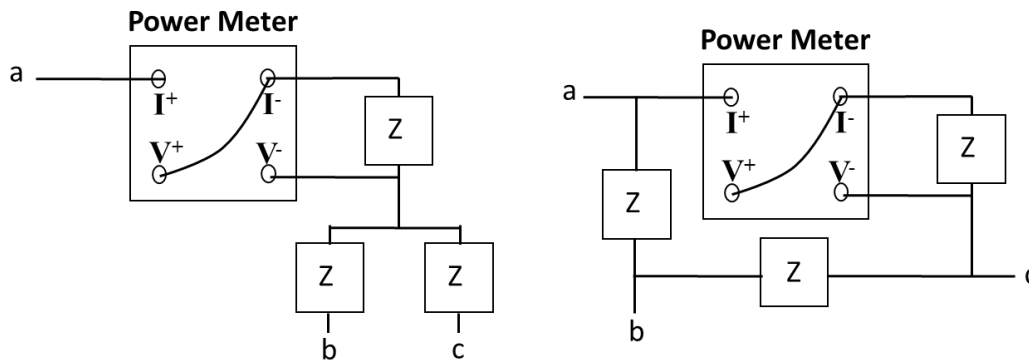

Figure 10-6 Single-Phase Wattmeter Measurement

Three-Phase Circuit with Delta-Load

1. Connect the Y- Δ balanced three-phase network described in Table 10-1 and include the two wattmeters as shown in Figure 10-5.
2. With the voltage initially adjusted to its minimum, turn the circuit breaker to the ON position and increase it slowly until the wattmeter #1 reads a line voltage of 120V. Be careful not to exceed 120V per phase.
3. Record the two power readings (with sign), the two line voltage readings, and the two line currents in Table 10-2.
4. Turn the circuit breaker of the three-phase source to the OFF position. **Caution:** Do not make changes to the network unless the circuit breaker is in the OFF position.
5. Remove the two wattmeters from the network connection. Then, insert one of the wattmeters into one of the phases (see Figure 10-6).
6. Turn the circuit breaker of the three-phase source to the ON position. Record in Table 10-3 the phase voltage, phase current, and phase power readings.
7. Turn the circuit breaker of the three-phase source to the OFF position. **Caution:** Do not make changes to the network unless the circuit breaker is in the OFF position.

DATA/OBSERVATIONS

Table 10-2: Power, Current and Voltage Readings from the Two-Wattmeters

Source-Load	Meter	Power (Watts)	Line Current (A)	Line Voltage (V)
Y-Y	1			
	2			
Y-Δ	1			
	2			

Table 10-3: Power, Current and Voltage Readings from Single Wattmeter

Source-Load	Power (Watts)	Phase Current (A)	Phase Voltage (V)
Y-Y			
Y-Δ			

INSTRUCTOR'S INITIALS:

DATE:

POST-LAB

Post-Lab questions must be answered in each experiment's laboratory report.

1. In a table, compare $S_{3\phi}$, $P_{3\phi}$, $Q_{3\phi}$ using the calculations in the prelab and the data obtained during the lab-session using the two-wattmeter method and the single wattmeter. Be sure the powers are total three-phase powers. Discuss any differences.
2. Using data from Table 10-3 calculate the impedance per-phase of the load and compare with the theoretical value. Discuss any differences.

Be sure to include all items from the post-lab exercise above in your written lab report.